



Tesla Said

John T. Ratzlaff

Tesla Said

Compiled by
John T. Ratzlaff



TESLA BOOK COMPANY

MILLBRAE, CALIFORNIA

1984

Published by
TESLA BOOK COMPANY
1580 Magnolia Avenue
Millbrae, California 94030

Library of Congress Catalog Card Number
83-72252

ISBN
0-914119-00-1

Copyright © 1984
by
John T. Ratzlaff
All rights reserved.

CONTENTS

	Page
<i>Acknowledgements</i>	<i>vi</i>
<i>Introduction</i>	<i>ix</i>
The Tesla Alternate Current Motor	1
Mr. Tesla on Alternate Current Motors	4
The Losses Due to Hysteresis in Transformers	7
Swinburne's "Hedgehog" Transformer	9
Tesla's New Alternating Motors	10
Experiments With Alternating Currents of High Frequency	13
Alternate Current Motors	15
Electro-motors	16
Phenomena of Currents of High Frequency	17
The "Drehstrom" Patent	19
The Ewing High-Frequency Alternator and Parson's Steam Engine	20
On the Dissipation of the Electrical Energy of the Hertz Resonator	22
The Physiological and Other Effects of High Frequency Currents	24
From Ni(c)ola Tesla - He Writes About His Experiments in Electrical Healing	25
Tesla's Latest Results	26
On Apparatus for Cathography	29
Mr. Tesla on Thermo Electricity	31
The Age of Electricity	31
Tesla's Latest Advances in Vacuum Tube Lighting	36
Tesla on Animal Training by Electricity	39
My Submarine Destroyer	40
Letter to Editor	43
Tesla Describes His Efforts in Various Fields of Work	43
Some Experiments in Tesla's Laboratory With Currents of High Potential and High Frequency	46
Tesla's New Discovery	57
Tesla's Wireless Light	59
Talking With Planets	61
Tesla Thinks Wind Power Should be Used More Now (Part of a series of articles by noted scientists)	66
A Striking Tesla Manifesto	72
Letter From Tesla (Refers to subway system)	74
Electric Autos	76

	Page
The Transmission of Electrical Energy Without Wires As a Means for Furthering Peace	78
Tesla on Subway Dangers	87
Tesla's Reply to Edison	88
Tesla On The Peary North Pole Expedition	90
Signalling to Mars - A Problem of Electrical Engineering	92
Tuned Lightning	94
Tesla's Wireless Torpedo	96
Wireless on Railroads	96
Ni(c)ola Tesla Objects	97
Tesla's Tidal Wave to Make War Impossible	98
Mr. Tesla on the Wireless Transmission of Power	102
Can Bridge Gap to Mars	103
Sleep From Electricity	105
Possibilities of "Wireless"	106
Tesla on Wireless	107
My Apparatus, Says Tesla	108
The Future of the Wireless Art	108
Nikola Tesla's Forecast for 1908	111
Mr. Tesla's Vision	112
Little Aeroplane Progress	113
Tesla on Aeroplanes	114
How to Signal Mars	115
What Science May Achieve This Year - New Mechancial Principle for the Conservation of Energy	119
Mr. Tesla on the Future	121
The Disturbing Influence of Solar Radiation on the Wireless Transmission of Energy	121
Nikola Tesla Plans to Keep "Wireless Thumb" on Ships at Sea	126
From Nikola Tesla (Tribute to George Westinghouse)	127
Tesla and Marconi	128
Correction by Mr. Tesla	131
Patent Wrapper, Patent 1,329,559, Valvular Conduit	132
Wonders of the Future	161
Nikola Tesla Tells of Country's War Problems	165
Minutes of the Edison Medal Meeting, May 18, 1917, with Nikola Tesla's Acceptance Speech on Receiving the Edison Medal	167
A Lighting Machine on Novel Principles	190
Famous Scientific Illusions	192

Page		Page
78	Tesla Answers Mr. Manierre and Further Explains the Axial Rotation of the Moon	200
87	The Moon's Rotation	202
88	The Moon's Rotation	204
90	Nikola Tesla Tells How We May Fly Eight Miles High at 1,000 Miles an Hour	209
92	Can Radio Ignite Balloons?	214
94	Signals to Mars Based on Hope of Life on Planet	219
96	Interplanetary Communication	222
96	Nikola Tesla on Electric Transmission	224
97	Nikola Tesla Tells of New Radio Theories	225
98	Mr. Tesla Speaks Out	227
102	Letter to Editor (On Marconi's feat)	229
103	On Future Motive Power	230
105	Dr. Tesla Writes of Various Phases of His Discovery	237
106	Statement of Tesla Relating to Force and Matter	238
107	Chewing Gum More Fatal Than Rum, Says Tesla	239
108	Pioneer Radio Engineer Gives Views on Power	240
108	Mr. Tesla Writes (Refers to J. P. Morgan)	243
111	Breaking up Tornadoes	244
112	Possibilities of Electrostatic Generators	250
113	Nikola Tesla Writes (Additional comments on electrostatic generators)	250
114	Tesla Sees Evidence Radio and Light Are Sound	258
115	Radio Power Will Revolutionize the World	261
119	Tribute to King Alexander	267
	German Cosmic Ray Theory Questioned	268
121	Nikola Tesla Tells How He Would Defend Ethiopia Against Italian Invasion	269
121	Prepared Statement of Tesla (For interview with press on 81st birthday observance)	272
126	Sending of Messages to Planets Predicted by Dr. Tesla on Birthday	276
127	Dr. Tesla Honors	279
128	Text of Tesla Speech for the Institute of Immigrant Welfare	280
131	Reference to Compass in 13th Century Poem	281
132	The Soviet Sacrifice of Spain	282
161	Story of Youth Told by Age	283
165	Mechanical Therapy	286
167	The New Tesla Electric Heater	288
190	Tesla's New System of Fluid Propulsion	289
192		

ACKNOWLEDGEMENTS

Burlingame Public Library, Burlingame, Calif.

California State Library, Sacramento, Calif.

Columbia University, Rare Book and Manuscript Library, New York City

Mechanics Institute Library, San Francisco, Calif.

San Mateo County Library, Belmont, Calif.

Smithsonian Institution, Div. of Electricity & Nuclear Energy, Washington, D. C.

Stanford University Libraries, Stanford, Calif.

A. L. Lez, San Anselmo, Calif.

Thorn L. Mayes, Saratoga, Calif.

Mildred Ratzlaff, Millbrae, Calif.

Electrical World Magazine

Science News Magazine

Scientific American Magazine

INTRODUCTION

The collection of articles and papers presented in this volume are in Nikola Tesla's own words; it is the most comprehensive single volume of Tesla's writings presently available. A period of over a quarter of a century has elapsed in gathering this material from every known source, in addition to searching archival material from the decades around the turn of the century.

Mr. Tesla speaks for himself and the reader is enabled to make first hand judgments rather than relying on the opinions of others. The subject matter is arranged in chronological order and includes a wide range of interesting and important information not previously published in book form.

It is becoming recognized that Tesla's discoveries and inventions in the areas of alternating current power generation and transmission, high frequency and high voltage, along with basic radio communication, are the fundamentals of the present world-wide technological growth. Power transmission in small and large quantities without wires included plans for transmission of sufficient energy to make a light spot on the moon, and transmission of messages as far as distant planets. Tesla's adversaries seized on these concepts with ridicule and for the purpose of undermining his credibility. In fact, there is now a systematic quest for life and intelligence through the medium of radio astronomy which is a legitimate part of our present space program.

Mr. Tesla continually expressed the contention that his system of electrical transmission was not by electromagnetic means, although the equipment did display these effects. His comments on the ether therefore are significant and differ from those of his contemporaries. It is unfortunate that one of the major hurdles in presenting new and fundamental discoveries is that of communication.

Among the long list of accomplishments are new lighting systems, development and public demonstration of radio control before 1900, and new concepts in the cosmic rays. In the healing arts, Tesla was far ahead in the development of x-ray equipment, studies of physiological and other effects of high frequency on humans, and mechanical therapy.

His thoughts encompassed the widest possible range, extending from treatises on the moon's rotation to finding a reference to the use of a compass in the 13th century. While by nature opposed to war, he developed specific plans for military application aimed at providing defense mechanisms to make war impossible.

A new turbine design, incorporating low cost, simplicity, efficiency and light weight is today a commercial reality. At the time of development, successful demonstrations by the inventor were well received only in technical journals and news accounts.

The name of Nikola Tesla as a leader in the electrical field was well recognized in this country and abroad in the 1890's and for a few years after 1900. The reasons for his fall into obscurity are numerous, but a major point that seems to be commonly overlooked is that a struggling inventor, several times on the verge of financial success, was the victim of economic situations beyond his control. The business difficulties of George Westinghouse resulted in payment of a minute fraction of the true value of the Tesla alternating current motor and generator patents. The crash of 1901 was the most devastating to Tesla and also to his backer, J. P. Morgan, and prevented completion of the Wardencllyffe, Long Island, installation. It should be pointed out that Tesla was only complimentary of his financial backers.

It is intended that the information presented will help in clarifying many missing details and, for the first time, make available some of Tesla's basic thoughts and ideas in areas which are in need of further development for the benefit of mankind.

JTR

THE TESLA ALTERNATE CURRENT MOTOR

The interest taken in M. Tesla's contributions to electrical apparatus and to electrical literature is so great, and the subject is so important, that we do not hesitate to give further space to the subject. On May 26 a communication on the subject from Dr. Louis Duncan, of Johns Hopkins University, appeared in our American contemporary, the *Electrical Review*, to the effect:

"We may, for our present purposes, divide motors into two classes; Continuous, in which the armature coils are unsymmetrical with respect to the poles, and which, therefore, give a practically constant torque, and alternating motors, in which the armature coils are symmetrical with respect to the poles, and which, therefore, give a torque varying both in magnitude and sign during a period of the counter E.M.F. The Tesla motor belongs to this latter class.

"In every motor the torque is equal to the rate of change of lines of induction through the armature circuit for a small angular displacement, multiplied by the armature current, or $\frac{dm}{dt}I$.

In the Tesla motor the first of these terms is greatest when the coil is opposite a pole and the field currents have their greatest amplitude. It is zero at a point about 45 deg. from this, supposing we neglect armature reactions. It depends on several things. The E.M.F. which determines it is due to changes in the number of lines of force passing through the armature circuit caused by (1) changes in the field currents; (2) the motion of the armature. The current depends on these E.M.F.'s, and on the reduced self-induction and resistance of its circuit. The motor can only do work when the first cause of E.M.F. is the greater, for a current in the direction of the ordinary counter E.M.F. would stop the motion. In some parts of a revolution the two E.M.F.'s work together, retarding the motion; in others, the induced E.M.F. produces a current causing the motor to revolve. It is impossible for me, with only a meagre description of the principles of the machine, to give an idea of the relative magnitude of these effects. Some of the results, however, are the following: Having given a definite number of reversals of the dynamo, there are a number of speeds, multiples of these reversals, at which the motor will govern itself when it is doing a certain amount of work. At one of these speeds, depending on the construction of the motor, the output will be a maximum. Now I see the statement that 'there is no difficulty whatever attendant upon starting the motor under load.' I cannot reconcile this with the above facts. That the torque for a smaller number of revolutions than ordinarily used, might be greater, one can readily see, since the counter E.M.F. is less in proportion to the induced E.M.F., but it must be remembered that for certain speeds even the induced current would tend to stop the motion; how the motor is to pass these critical speeds I do not see. Again, if the maximum load is suddenly thrown on while the motor is running at its proper speed, then, if the inertia be great, the motor will fall behind its point of maximum work, and either stop or take up some slower speed.

"What the possible efficiency and output of the motor may be, only experiment will tell. I have shown* that the output of an ordinary alternating current motor is equal to that of a continuous current motor, supplied with a corresponding E.M.F. The efficiency might be great, but it has the disadvantage that about the same current flows for no work and maximum work, so for light loads the efficiency can hardly be very high.

"With our present knowledge of alternating currents it is useless to attempt to calculate from the simple though misleading assumptions ordinarily made, the

**Inst. Elec. Engineers*, Feb., 1888.

output, conditions of maximum work, &c., of this machine. Experiment alone can determine its value, and one properly conducted and interpreted set of experiments should enable us to judge both the merit of the invention and its best possible form. I cannot see, however, how, in the form described in the last issue of this journal the motor can work under conditions of a suddenly varying load as satisfactorily as continuous current motors."

To the above Mr. Tesla replied on June 2 as follows:

"I find in your issue of last week a note of Mr. Duncan referring to my system of alternate current motors.

"As I see that Dr. Duncan has not as yet been made acquainted with the real character of my invention, I cannot consider his article in the light of a serious criticism, and would think it unnecessary to respond; but desiring to express my consideration for him and the importance which I attach to his opinion, I will point out here briefly the characteristic features of my invention, inasmuch as they have a direct bearing on the article above referred to.

"The principle of action of my motor will be well understood from the following: By passing alternate currents in proper manner through independent energising circuits in the motor, a progressive shifting or rotation of the poles of the same is effected. This shifting is more or less continuous according to the construction of the motor and the character and relative phase of the currents which should exist in order to secure the most perfect action.

"If a laminated ring be wound with four coils, and the same be connected in proper order to two independent circuits of an alternate current generator adapted for this purpose, the passage of the currents through the coils produces

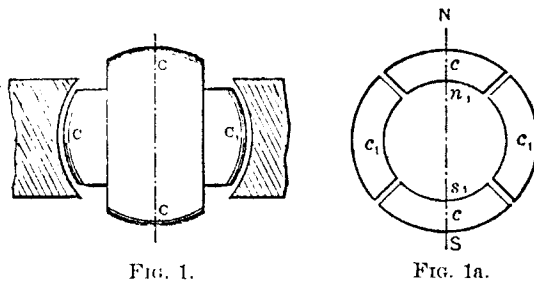

FIG. 1.

FIG. 1a.

theoretically a rotation of the poles of the ring, and in actual practice, in a series of experiments, I have demonstrated the complete analogy between such a ring and a revolving magnet. From the application of this principle to the operation of motors, two forms of motor of a character widely differing have resulted—one designed for constant and the other for variable load. The misunderstanding of Dr. Duncan is due to the fact that the prominent features of each of these two forms have not been specifically stated. In illustration of a representative of the second class, I refer to Fig. 1, given herewith. In this instance, the armature of the motor is provided with two coils at right angles. As it may be believed that a symmetrical arrangement of the coils with respect to the poles is required, I will assume that the armature is provided with a great number of diametrically wound coils or conductors closed upon themselves, and forming as many independent circuits. Let it now be supposed that the ring is permanently magnetized so as to show two poles (N and S) at two points diametrically opposite, and that it is rotated by mechanical power. The armature being stationary, the rotation of the ring magnet will set up currents in the closed armature coils. These currents will be most intense at or near the points of the greatest density of the force, and they will produce poles upon the armature core at right angles to those of the ring. Of course there will be other elements entering into action

which will tend to modify this, but for the present they may be left unconsidered. As far as the location of the poles upon the armature core is concerned, the currents generated in the armature coils will always act in the same manner, and will maintain continuously the poles of the core in the same position, with respect to those of the ring in any position of the latter, and independently of the speed. From the attraction between the core and the ring, a continuous rotary effort, constant in all positions, will result, the same as in a continuous current motor with a great number of armature coils. If the armature be allowed to turn, it will revolve in the direction of rotation of the ring magnet, the induced current diminishing as the speed increases, until upon the armature reaching very nearly the speed of the magnet, just enough current will flow through the coils to keep up the rotation. If, instead of rotating the ring by mechanical power, the poles of the same are shifted by the action of the alternate currents in the two circuits, the same results are obtained.

"Now compare this system with a continuous current system. In the latter we have alternate currents in the generator and motor coils, and intervening devices for commutating the currents, which on the motor besides effect automatically a progressive shifting or rotation of the poles of the armature; here we have the same elements and identically the same operation, but without the commutating devices. In view of the fact that these devices are entirely unessential to the operation, such alternate current system will - at least in many respects - show a complete similarity with a continuous current system, and the motor will act precisely like a continuous current motor. If the load is augmented, the speed is diminished and the rotary effort correspondingly increased, as more current is made to pass through the energising circuits; load being taken off, the speed increases, and the current, and consequently the effort, is lessened. The effort, of course, is greatest when the armature is in the state of rest.

"But, since the analogy is complete, how about the maximum efficiency and current passing through the circuits when the motor is running without any load? one will naturally inquire. It must be remembered that we have to deal with alternate currents. In this form the motor simply represents a transformer, in which currents are induced by a dynamic action instead of by reversals, and, as it might be expected, the efficiency will be maximum at full load. As regards the current, there will be - at least, under proper conditions - as wide a variation in its strength as in a transformer, and, by observing proper rules, it may be reduced to any desired quantity. Moreover, the current passing through the motor when running free, is no measure for the energy absorbed, since the instruments indicate only the numerical sum of the direct and induced electromotive forces and currents instead of showing their difference.

"Regarding the other class of these motors, designed for constant speed, the objections of Dr. Duncan are, in a measure applicable to certain constructions, but it should be considered that such motors are not expected to run without any, or with a very light load; and, if so, they do not, when properly constructed, present in this respect any more disadvantage than transformers under similar conditions. Besides, both features, rotary effort and tendency to constant speed, may be combined in a motor, and any desired preponderance may be given to either one, and in this manner a motor may be obtained possessing any desired character and capable of satisfying any possible demand in practice.

"In conclusion, I will remark, with all respect to Dr. Duncan, that the advantages claimed for my system are not mere assumptions, but results actually obtained, and that for this purpose experiments have been conducted through a long period, and with an assiduity such as only a deep interest in the invention could inspire; nevertheless, although my motor is the fruit of long labour and careful investigation, I do not wish to claim any other merit beyond that of having invented it, and I leave it to men more competent than myself to determine the true laws of

the principle and the best mode of its application. What the result of these investigations will be the future will tell; but whatever they may be, and to whatever this principle may lead, I shall be sufficiently recompensed if later it will be admitted that I have contributed a share, however small, to the advancement of science."

Electrical World - N. Y.
May 25, 1889, pp. 297-298.

MR. NIKOLA TESLA ON ALTERNATING CURRENT MOTORS.

To the Editor of The Electrical World:

SIR: About a year ago I had the pleasure of bringing before the American Institute of Electrical Engineers the results of some of my work on alternate current motors. They were received with the interest which novel ideas never fail to excite in scientific circles, and elicited considerable comment. With truly American generosity, for which, on my part, I am ever thankful, a great deal of praise through the columns of your esteemed paper and other journals has been bestowed upon the originator of the idea, in itself insignificant. At that time it was impossible for me to bring before the Institute other results in the same line of thought. Moreover, I did not think it probable - considering the novelty of the idea - that anybody else would be likely to pursue work in the same direction. By one of the most curious coincidences, however, Professor Ferraris not only came independently to the same theoretical results, but in a manner identical almost to the smallest detail. Far from being disappointed at being prevented from calling the discovery of the principle exclusively my own, I have been excessively pleased to see my views, which I had formed and carried out long before, confirmed by this eminent man, to whom I consider myself happy to be related in spirit, and toward whom, ever since the knowledge of the facts has reached me, I have entertained feelings of the most sincere sympathy and esteem. In his able essay Prof. Ferraris omitted to mention various other ways of accomplishing similar results, some of which have later been indicated by O. B. Shallenberger, who some time before the publication of the results obtained by Prof. Ferraris and myself had utilized the principle in the construction of his now well known alternate current meter, and at a still later period by Prof. Elihu Thomson and Mr. M. J. Wightman.

Since the original publications, for obvious reasons, little has been made known in regard to the further progress of the invention; nevertheless the work of perfecting has been carried on indefatigably with all the intelligent help and means which a corporation almost unlimited in its resources could command, and marked progress has been made in every direction. It is therefore not surprising that many unacquainted with this fact, in expressing their views as to the results obtained, have grossly erred.

In your issue of May 4 I find a communication from the electricians of Ganz & Co., of Budapest, relating to certain results observed in recent experiments with a novel form of alternate current motor. I would have nothing to say in regard to this communication unless it were to sincerely congratulate these gentlemen on any good results which they may have obtained, but for the article, seemingly inspired by them, which appeared in the London *Electrical Review* of April 26, wherein certain

erroneous views are indorsed and some radically false assertions made, which, though they may be quite unintentional, are such as to create prejudice and affect material interests.

As to the results presented, they not only do not show anything extraordinary, but are, in fact, considerably below some figures obtained with my motors a long time ago. The main stress being laid upon the proposition between the apparent and real energy supplied, or perhaps more directly, upon the ratio of the energy apparently supplied to, and the real energy developed by, the motor, I will here submit, with your permission, to your readers, the results respectively arrived at by these gentlemen and myself.

Energy apparently supplied in watts.		Work performed in watts.		Ratio of energy apparently supplied to the real energy developed.	
Ganz & Co.	Westinghouse Co.	Ganz & Co.	Westinghouse Co.	Ganz & Co.	Westinghouse Co.
18,000	21,840	11,000	17,595	0.611	0.805
24,200	30,295	14,600	25,365	0.603	0.836
29,800	43,624	22,700	36,915	0.761	0.816
.....	56,800	48,675	0.856
.....	67,500	59,440	0.88
.....	79,100	67,365	0.851

If we compare these figures we will find that the most favorable ratio in Ganz & Co's motor is 0.761, whereas in the Westinghouse, for about the same load, it is 0.836, while in other instances, as may be seen, it is still more favorable. Notwithstanding this, the conditions of the test were not such as to warrant the best possible results.

The factors upon which the apparent energy is mainly dependent could have been better determined by a proper construction of the motor and observance of certain conditions. In fact, with such a motor a current regulation may be obtained which, for all practical purposes, is as good as that of the direct current motors, and the only disadvantage, if it be one, is that when the motor is running without load the apparent energy cannot be reduced quite as low as might be desirable. For instance, in the case of this motor the smallest amount of apparent energy was about 3,000 watts, which is certainly not very much for a machine capable of developing 90 h. p. of work; besides, the amount could have been reduced very likely to 2,000 watts or less.

On the other hand, these motors possess the beautiful feature of maintaining an absolutely constant speed no matter how the load may vary. This feature may be illustrated best by the following experiment performed with this motor. The motor was run empty, and a load of about 200 h. p., far exceeding the normal load, was thrown on suddenly. Both armatures of the motor and generator were seen to stop for an instant, the belts slipping over the pulleys, whereupon both came up to the normal speed with the full load, not having been thrown out of synchronism. The experiment could be repeated any number of times. In some cases, the driving power being sufficient, I have been enabled to throw on a load exceeding 8 to 9 times that which the motor was designed to carry, without affecting the speed in the least.

This will be easily understood from the manner in which the current regulation is effected. Assuming the motor to be running without any load, the poles of the armature and field have a certain relative position which is that of the highest self-induction or counter electromotive force. If load be thrown on, the poles are made to recede; the self-induction or counter electromotive force is thereby diminished and more current passed through the stationary or movable armature-coils. This regulation is very different from that of a direct current motor. In the latter the current is varied by the motor losing a certain number of revolutions in proportion to the load, and the regulation would be impossible if the speed would be maintained constant; here the whole regulation is practically effected during a fraction of one revolution only. From this it is also apparent that it is a practical impossibility to throw such a motor out of synchronism, as the whole work must be done in an instant, it being evident that if the load is not sufficient to make a motor lose a fraction of the first revolution it will not be able to do so in the succeeding revolutions. As to the efficiency of these motors, it is perfectly practicable to obtain 94 to 95 per cent.

The results above given were obtained on a three-wire system. The same motor has been started and operated on two wires in a variety of ways, and although it was not capable of performing quite as much work as on three wires, up to about 60 h. p. it gave results practically the same as those above-mentioned. In fairness to the electricians of Ganz & Co., I must state here that the speed of this motor was higher than that used in their experiments, it being about 1,500. I cannot make due allowance for this difference, as the diameter of the armature and other particulars of the Ganz & Co. motor were not given.

The motor tested had a weight of about 5,000 lbs. From this it will be seen that the performance even on two wires was quite equal to that of the best direct current motors. The motor being of a synchronous type, it might be implied that it was not capable of starting. On the contrary, however, it had a considerable torque on the start and was capable of starting under fair load.

In the article above referred to the assertion is made that the weight of such alternate current motor, for a given capacity, is "several times" larger than that of a direct current motor. In answer to this I will state here that we have motors which with a weight of about 850 pounds develop 10 h. p. with an efficiency of very nearly 90 per cent, and the spectacle of a direct current motor weighing, say 200 - 300 pounds and performing the same work, would be very gratifying for me to behold. The motor which I have just mentioned had no commutator or brushes of any kind nor did it require any direct current.

Finally, in order to refute various assertions made at random, principally in the foreign papers, I will take the liberty of calling to the attention of the critics the fact that since the discovery of the principle several types of motors have been perfected and of entirely different characteristics, each suited for a special kind of work, so that while one may be preferable on account of its ideal simplicity, another might be more efficient. It is evidently impossible to unite all imaginable advantages in one form, and it is equally unfair and unreasonable to judge all different forms according to a common standard. Which form of the existing motors is best, time will show; but even in the present state of the art we are enabled to satisfy any possible demand in practice.

Nikola Tesla
Pittsburgh, Pa.

THE LOSSES DUE TO HYSTERESIS IN TRANSFORMERS.

In your issue of April 2, in referring to certain remarks made by me at the recent meeting of the American Institute of Electrical Engineers on the subject of hysteresis you make the statement: "It is this constancy of relation that, as Mr. Tesla pointed out * * * may ultimately establish the correctness of the hypothesis advanced, that in reality there is no loss due to hysteresis, and that the changes of magnetization represent a charging and discharging of molecular energy without entailing an actual expenditure of energy."

I do not recollect having made such a statement, and as I was evidently misunderstood, you will greatly oblige me in inserting the following few lines, which express the idea I meant to advance:

Up to the present no satisfactory explanation of the causes of hysteresis has been given. In the most exhaustive and competent treatise on the theory of transformers, by Fleming, static hysteresis is explained by supposing that "the magnetic molecules or molecular magnets, the arrangement of which constitutes magnetization, move stiffly, and the dissipation of energy is the work done in making the necessary magnetic displacement against a sort of magnetic friction." Commonly it is stated that this is a distinct element in the loss of energy in an iron core undergoing magnetic changes entirely independent of any currents generated therein.

Now it is difficult to reconcile these views with our present notions on the constitution of matter generally. The molecules or iron cannot be connected together by anything but elastic forces, since they are separated by an intervening elastic medium through which the forces act; and this being the case is it not reasonable to assume that if a given amount of energy is taken up to bring the molecules out of their original position an equivalent amount of energy should be restored by the molecules reassuming their original positions, as we know is the case in all molecular displacements? We cannot imagine that an appreciable amount of energy should be wasted by the elastically connected molecules swinging back and forth from their original positions, which they must constantly tend to assume, at least within the limit of elasticity, which in all probability is rarely surpassed. The losses cannot be attributed to mere displacement, as this would necessitate the supposition that the molecules are connected rigidly, which is quite unthinkable.

A current cannot act upon the particles unless it acts upon currents in the same, either previously existing or set up by it, and since the particles are held together by elastic forces the losses must be ascribed wholly to the current generated. The remarkable discovery of Ewing that the magnetization is greater on the descent than on the ascent for the same values of magnetizing force strongly points to the fact that hysteresis is intimately connected with the generation of currents either in the molecules individually or in groups of them through the space intervening. The fact observed accords perfectly with our experience on current induction, for we know that on the descent any current set up must be of the same direction with the inducing current, and, therefore, must join with the same in producing a common effect; whereas, on the ascent the contrary is the case.

Dr. Duncan stated that the ratio of increase of primary and secondary current is constant. This statement is, perhaps, not sufficiently expressive, for not only is the ratio constant but, obviously, the differential effect of primary and secondary is constant. Now any current generated - molecular or Foucault currents in the mass - must be in amount proportionate to the difference of the inductive effect of the primary and secondary, since both currents add algebraically - the ratio of windings duly considered, - and as this difference is constant the loss, if wholly

accounted for in this manner, must be constant. Obviously I mean here the transformers under consideration, that is, those with a closed magnetic circuit, and I venture to say that the above will be more pronounced when the primary and secondary are wound one on top of the other than when they are wound side by side; and generally it will be the more pronounced the closer their inductive relation.

Dr. Duncan's figures also show that the loss is proportionate to the square of the electromotive force. Again this ought to be so, for an increased electromotive force causes a proportionately increased current which, in accordance with the above statements, must entail a loss in the proportion of the square.

Certainly, to account for all the phenomena of hysteresis, effects of mechanical vibration, the behavior of steel and nickel alloy, etc., a number of suppositions must be made; but can it not be assumed that, for instance, in the case of steel and nickel alloys the dissipation of energy is modified by the modified resistance; and to explain the apparent inconsistency of this view we only need to remember that the resistance of a body as a whole is not a measure of the degree of conductivity of the particles of which it is composed.

N. Tesla
New York City

SWINBURNE'S "HEDGEHOG" TRANSFORMER.

BY NIKOLA TESLA.

SOME time ago Mr. Swinburne advanced certain views on transformers which have elicited some comment. In THE ELECTRICAL ENGINEER of Sept. 10, there are brought out further arguments on behalf of his open circuit, or, as he calls it, "hedgehog" transformer, claiming for this type a higher average efficiency than is attainable with the closed circuit forms. In regard to this, I say with Goethe, "Die Botschaft hör' ich wohl, allein mir fehlt der Glaube—I hear the message, but I lack belief."

Many of Mr. Swinburne's arguments are in my opinion erroneous. He says: "In calculating the efficiencies of transformers, the loss in the iron has generally been left completely out of account, and the loss in copper alone considered; hence, the efficiencies of 97 and 98 per cent. claimed for closed iron circuit forms." This is a statement little complimentary to those who have made such estimates, and perhaps Mr. Swinburne would be very much embarrassed to cite names on behalf of his argument. He assumes the loss in the iron in the closed circuit forms to be 10 per cent. of the full load, and further "that in most stations the average use of lamps is less than two hours a day, including all lamps installed," and arrives at some interesting figures in regard to efficiency. Mr. Swinburne seems not to be aware of the improvements made in the iron. The loss with the best quality of iron will, I believe, not reach 6 per cent. of the full load by an intelligent use of the transformer, and there is no doubt that further improvements will be made in that direction.

As regards the second part of his assumption, I think that it is exaggerated. It must be remembered that in most central stations or large plants due care is taken that the load is favorably distributed and in many cases the wiring is such that entire circuits may be shut off at certain hours so that there is during these hours no loss whatever in the transformers.

In his "hedgehog" form of transformer Mr. Swinburne reduces the iron considerably and comes to the conclusion that even in small transformers the iron loss is under one per cent. of the full load, while in the closed circuit forms, it is, according to him, 10 per cent. It would strengthen this argument if the iron would be dispensed with altogether. Mr. Swinburne does not appreciate fully the disadvantages which the open circuit form, operated at the usual period, entails. In order that the loss in the iron should be reduced to one-tenth, it is necessary to reduce the weight of the iron core to one-tenth and subject every unit length of the same to the same magneto-motive force. If a higher magneto-motive force is used the loss in the core will—within certain limits, at least—be proportionate to the square of the magneto-motive force. The remark of Mr. Swinburne, "If the iron circuit is opened, the sides of the embracing core can be removed, so the loss by hysteresis is divided by three," is therefore not true; the loss will be divided by $3 \times \frac{F_1^2}{F^2}$ where

$F_1 > F$. If the iron of the open circuit form is made up in a closed ring the advantage will be at once apparent, for, since the magnetic resistance will be much reduced, the magneto-motive force required will be correspondingly smaller. It is probable that, say, four Swinburne transformers may be joined in such a way as to form a closed

magnetic circuit. In this case the amount of iron and copper would remain the same, but an advantage will be gained as the total magnetic resistance will be diminished. The four transformers will now demand less excitation and since—under otherwise equal conditions—the gain depends on the square of the existing current, it is by no means insignificant. From the above comparison it is evident that the core of such open circuit transformer should be very short, by far shorter than it appears from the cut in THE ELECTRICAL ENGINEER.

Mr. Swinburne is in error as to the motives which have caused the tendency to shorten the magnetic circuit in closed circuit transformers. It was principally on account of practical considerations and not to reduce the magnetic resistance, which has little to do with efficiency. If a ring be made of, say, 10 centimetres mean length and 10 square centimetres cross-section, and if it be wound all over with the primary and secondary wires, it will be found that it will give the best result with a certain number of alternations. If, now, a ring is made of the same quality of iron but having, say, 20 centimetres mean length and 10 square centimetres section it will give again the best result with the same number of alternations, and the efficiency will be the same as before, provided that the ring is wound all over with the primary and secondary wires. The space inside of the ring will, in the second case, be increased in proportion to the square of the diameter, and there will be no difficulty in winding on it all the wire required. So the length may be indefinitely increased and a transformer of any capacity made, as long as the ring is completely covered by the primary and secondary wires.

If the wires be wound side by side the ring of smaller diameter will give a better result, and the same will be the case if a certain fraction of the ring is not covered by the wires. It then becomes important to shorten the magnetic circuit. But, since in practice it is necessary to enclose the transformer in a casting, if such a ring be made, it would have to be protected with a layer of laminated iron, which would increase the cost and loss. It may be inclosed in jars of some insulating material, as Mr. Swinburne does, but this is less practicable.

Owing to this, the constructors of the most practical forms, such, for instance, as the Westinghouse transformer, to which the Swinburne reasoning applies, have been prompted to enclose the wires as much as possible with the laminated iron, and then it became important to shorten the magnetic circuit, because in this form only a part of the magnetic circuit is surrounded by the wires, as well as for other practical considerations.

In practice it is desirable to get along with the least length of copper conductor on account of cheapness and regulation. Mr. Swinburne states that in his transformer the loss in iron is under one per cent. of the full load; all the balance of loss must, therefore, be in the copper. But since, according to him, the wires are of larger section, his transformer can hardly be an improvement in that direction. The gun-metal casting is also objectionable. There is no doubt some loss going on in the same, and besides it

increases the resistance of the wires by a factor $\sqrt{\frac{S}{S_1}}$

where S is the total cross-section of the core and S_1 the section of the iron wires. There is one important point which seems to have escaped Mr. Swinburne's attention. Whether the open circuit transformer is an improvement, or not, will depend principally on the period. The experience of most electrical engineers has resulted in the adoption of the closed circuit transformer. I believe that I was the first to advocate an open circuit form, but to improve its efficiency I had to use a much higher period; at usual periods the closed circuit form is preferable.

Mr. Swinburne makes some other obscure statements upon which I need not dwell, as they have no bearing on the main question.

CORRESPONDENCE.

LETTERS TO THE EDITOR.

Notice to Correspondents.

We do not hold ourselves responsible for the opinions of our correspondents. Anonymous communications cannot be noticed. The Editor respectfully requests that all communications may be drawn up as briefly and as much to the point as possible. In order to facilitate reference, correspondents, when referring to any letter previously inserted will oblige by mentioning the serial number of such letter, and of the page on which it appears. Sketches and drawings for illustrations should be on separate pieces of paper. All communications should be addressed Editor of THE ELECTRICAL ENGINEER, 150 Broadway, New York city.

TESLA'S NEW ALTERNATING MOTORS.

[139.]—I hope you will allow me the privilege to say in the columns of your esteemed journal a few words in regard to an article which appeared in *Industries* of August 22, to which my attention has been called. In this article an attempt is made to criticise some of my inventions, notably those which you have described in your issue of August 6, 1890.

The writer begins by stating: "The motor depends on a shifting of the poles under certain conditions, a principle which has been *already*¹ employed by Mr. A. Wright in his alternating current meter." This is no surprise to me. It would rather have surprised me to learn that Mr. Wright has *not yet* employed the principle in his meter, considering what, before its appearance, was known of my work on motors, and more particularly of that of Schallenberger on meters. It has cost me years of thought to arrive at certain results, by many believed to be unattainable, for which there are now numerous claimants, and the number of these is rapidly increasing, like that of the colonels in the South after the war.

The writer then good-naturedly explains the theory of action of the motive device in Wright's meter, which has greatly benefited me, for it is so long since I have arrived at this, and similar theories, that I had almost forgotten it. He then says: "Mr. Tesla has worked out some more or less complicated motors on this principle, but the curious point is that he has completely misunderstood the theory of the phenomena, and has got hold of the old fallacy of screening." This may be *curious*, but how much *more curious* it is to find that the writer in *Industries* has *completely misunderstood* everything himself. I like nothing better than just criticism of my work, even if it be severe, but when the critic assumes a certain "l'état c'est moi" air of unquestioned competency I want him to know what he is writing about. How little the writer in *Industries* seems to know about the matter is painfully apparent when he connects the phenomenon in Wright's meter with the subject he has under consideration. His further remark, "He (Mr. Tesla) winds his secondary of iron instead of copper and thinks the effect is produced magnetically," is illustrative of the care with which he has perused the description of the devices contained in the issue of THE ELECTRICAL ENGINEER above referred to.

I take a motor having, say eight poles, and wrap the exciting coils of four alternate cores with fine insulated iron wire. When the current is started in these coils it encounters the effect of the closed magnetic circuit and is retarded. The magnetic lines set up at the start close to the iron wire around the coils and no free poles appear at first at the ends of the four cores. As the current rises in the coils more lines are set up, which crowd more and more in the fine iron wire until finally the same becomes saturated, or nearly so, when the shielding action of the iron wire ceases and free poles appear at the ends of the four protected cores. The effect of the iron wire, as will be seen, is two-fold. First, it retards the energizing current; and second, it delays the appearance of the free poles. To produce a still greater difference of phase in the magnetization of the protected and unprotected cores, I connect the iron wire surrounding the coils of the former in series with the coils of the latter, in which case, of course, the iron wire is preferably wound or connected differentially, after the fashion of the resistance coils in a bridge, so as to have no appreciable self-induction. In other cases I obtain the desired retardation in the appearance of the free poles on one set of cores by a magnetic shunt, which produces a greater retardation of the current and takes up at the start a certain number of the lines set up, but becomes saturated when the current in the exciting coils reaches a predetermined strength.

In the transformer the same principle of shielding is utilized. A primary conductor is surrounded with a fine layer of laminated iron, consisting of fine iron wire or plates properly insulated and interrupted. As long as the current in the primary conductor is so small that the iron enclosure can carry all the lines of force set up by the current, there is very little action exerted upon a secondary conductor placed in vicinity to the first; but just as soon as the iron enclosure becomes saturated, or nearly so, it loses the virtue of protecting the secondary and the inducing action of the primary practically begins. What, may I ask, has all this to do with the "old fallacy of screening?"

With certain objects in view—the enumeration of which would

PITTSBURGH.

An Electric Process for Making "Wrought" Iron—Regulating the Wires.

A PROCESS of making wrought iron from pig metal without puddling is one of the discoveries made by Dr. Emmens, of Greensburg, near this city. The doctor accomplishes his object with the aid of electricity. He takes a vat which is filled with a chemical solution and a number of thin sheet iron plates. Then, the pig iron is also placed in the vat, after which the pig iron and the sheet iron are connected with a dynamo. The current generated by the dynamo is said to have the effect of causing the pure iron to be separated from the impurities in the pig iron and form a deposit on the sheet iron plates.

The quality of this wrought iron is stated to be superior to that of the best Swedish metal. It can be bent, rolled or twisted into any shape, while cold. Dr. Emmens says that he can take a horse shoe nail of this iron, fasten the head in a vice and twist it into an almost perfect screw without breaking.

An ordinance providing for the regulation of electric wires in the streets will be acted upon by councils within the next few days. All the electric wires must be placed at least twenty feet above the side walks, and where there are street railway wires on the same street; the former wires must be a sufficient distance above the others so as not to interfere. Underground wires, cables, tubes, conduits and subways shall be placed at least two feet under the ground and as near the street curb as practicable.

PITTSBURGH, Sept. 18, 1890.

ST. LOUIS.

Electric Railway News.—Resignations and Appointments.—The Turner Unicycle Road.

DURING the summer months the work of changing the motive power on the Lindell Railway has progressed steadily, but with some delay at times on account of scarcity of material of all kinds. The policy of the company is to construct a first-class electric railway regardless of cost and time. The new power house is finished and the machinery is being placed in position. Six boilers are set and ready for steam. Eight dynamos are on hand and being set up, and the first of the four 400 h. p. Armington & Sims engines is expected to arrive about the 20th.

The Vandeventer Avenue Street Railway will be operated as a part of the Lindell Railway. The construction of this road is being pushed to completion with the same thoroughness as the main line of the Lindell, the intention being to have it in operation by October 1 so as to accommodate visitors to the St. Louis Agricultural Fair. The Vandeventer avenue line will extend from Chouteau avenue to the fair grounds, and will thus form a direct line from Union Depot to the fair grounds. The acquisition of the Vandeventer line gives the Lindell Railway Company a total of 18 miles of double track.

Mr. E. J. Bagnall has resigned his position as superintendent of the St. Louis Illuminating Company and has accepted the position of engineer of the Lindell Railway Company, and will have complete charge of everything pertaining to mechanical and electrical engineering.

The St. Louis Unicycle Railway Company has been incorporated under the laws of the State of Missouri, with a capital stock of \$200,000, with the following officers: President, L. A. Brown; vice-presidents, John H. French and J. W. Tremayne; treasurer, W. A. Adams; secretary, Chas. H. Wengler; directors, Chas. H. Gleason, Chas. H. Blake and David Strawbridge. The Unicycle railway is the invention of E. M. Turner, of Texas, and is an elevated electric railway having only one rail. A motor car propelled by a one h. p. Sprague electric motor is now in operation at the exposition.

The McKee street railway syndicate have closed a contract with the Short Electric Railway Company for 1,000 motors. This syndicate has been formed lately for the purpose of purchasing, constructing and operating electric railways, and this order is given so as to have the motors ready for use as fast as they may be required.

Mr. C. L. Abbott has resigned his position as superintendent of the Short Electric Railway, on the south end of the St. Louis railroad, and has accepted the position of superintendent of the Glenwood and Greenlawn Street Railway, Sprague system, Columbus, O., and will leave shortly for his new field of labor.

The Board of Public Improvements have appointed Andrew J. O'Reilly supervisor of city lighting in place of E. V. Matlack. No specific charges were brought against Mr. Matlack by the board, the change being made merely to quiet a general dissatisfaction which has existed since Mr. Matlack's appointment over a year

lead me too far—an arrangement was shown in *THE ELECTRICAL ENGINEER*, about which the writer in *Industries* says: "A ring of laminated iron is wound with a secondary. It is then encased in iron laminated in the *wrong direction* and the primary is wound outside of this. The layer of iron between the primary and secondary is supposed to screen the coil. Of course it cannot do so, such a thing is unthinkable." This reminds me of the man who had committed some offense and engaged the services of an attorney. "They cannot commit you to prison for that," said the attorney. Finally the man was imprisoned. He sent for the attorney. "Sir," said the latter, "I tell you they cannot imprison you for that." "But, sir," retorted the prisoner, "they have imprisoned me." It may not screen, in the opinion of the writer in *Industries*, but just the same it does. According to the arrangement the principal effect of the screen may be either a retardation of the action of the primary current upon the secondary circuit or a deformation of the secondary current wave with similar results for the purposes intended. In the arrangement referred to by the writer in *Industries* he seems to be certain that the iron layer acts like a choking coil; there again he is mistaken; it does not act like a choking coil, for then its capacity for maintaining constant current would be very limited. But it acts more like a magnetic shunt in constant current transformers and dynamos, as, in my opinion, it ought to act.

There are a good many more things to be said about the remarks contained in *Industries*. In regard to the magnetic time lag the writer says: "If a bar of iron has a coil at one end, and if the core is perfectly laminated, on starting a current in the coil the induction *all along the iron* corresponds to the excitation at that instant, unless there is a microscopic time lag, of which there is no evidence." Yet a motor was described, the very operation of which is dependent on the time lag of magnetization of the different parts of a core. It is true the writer uses the term "perfectly laminated" (which, by the way, I would like him to explain), but if he intends to make such a "perfectly laminated" core I venture to say there is trouble in store for him. From his remarks I see that the writer completely overlooks the importance of the size of the core and of the number of the alternations pointed out; he fails to see the stress laid on the saturation of the screen, or shunt, in some of the cases described; he does not seem to recognize the fact that in the cases considered the formation of current is reduced as far as practicable in the screen, and that the same, therefore, so far as its quality of screening is concerned, has no role to perform as a conductor. I also see that he would want considerable information about the time lag in the magnetization of the different parts of a core, and an explanation why, in the transformer he refers to, the screen is laminated in the *wrong direction*, etc.—but the elucidation of all these points would require more time than I am able to devote to the subject. It is distressing to find all this in the columns of a leading technical journal.

In conclusion, the writer shows his true colors by making the following withering remarks: "It is questionable whether the Tesla motor will ever be a success. Such motors will go round, of course, and will give outputs, but their efficiency is doubtful; and if they need three-wire circuits and special generators there is no object in using them, as a direct current motor can be run instead with advantage."

No man of broad views will feel certain of the success of any invention, however good and original, in this period of feverish activity, when every day may bring new and unforeseen developments. At the pace we are progressing the permanence of all our apparatus its present forms becomes more and more problematical. It is impossible to foretell what type of motor will crystallize out of the united efforts of many able men; but it is my conviction that at no distant time a motor having commutator and brushes will be looked upon as an antiquated piece of mechanism. Just how much the last quoted remarks of the writer of *Industries*—considering the present state of the art—are justified, I will endeavor to show in a few lines.

First, take the transmission of power in isolated places. A case frequently occurring in practice and attracting more and more the attention of engineers is the transmission of large powers at considerable distances. In such a case the power is very likely to be cheap, and the cardinal requirements are then the reduction of the cost of the leads, cheapness of construction and maintenance of machinery and constant speed of the motors. Suppose a loss of only 25 per cent. in the leads, at full load, be allowed. If a direct current motor be used, there will be, besides other difficulties, considerable variation in the speed of the motor—even if the current is supplied from a series dynamo—so much so that the motor may not be well adapted for many purposes, for instance, in cases where direct current transformation is contemplated with the object of running lights or other devices at constant potential. It is true that the condition may be bettered by employing proper regulating devices, but these will only further complicate the already complex system, and in all probability fail to secure such perfection as will be desired. In using an ordinary single-circuit alternate current motor the disadvantage is that the motor has no starting torque and that, for equal weight, its output and efficiency are more or less below that

of a direct current motor. If, on the contrary, the armature of any alternator or direct current machine—large, low-speed, two-pole machines will give the best results—is wound with two circuits, a motor is at once obtained which possesses sufficient torque to start under considerable load; it runs in absolute synchronism with the generator—an advantage much desired and hardly ever to be attained with regulating devices; it takes current in proportion to the load, and its plant efficiency within a few per cent. is equal to that of a direct current motor of the same size. It will be able, however, to perform more work than a direct current motor of the same size, first, because there will be no change of speed, even if the load be doubled or tripled, within the limits of available generator power; and, second, because it can be run at a higher electromotive force, the commutator and the complication and difficulties it involves in the construction and operation of the generators and motors being eliminated from the system. Such a system will, of course, require three leads, but since the plant efficiency is practically equal to that of the direct current system, it will require the same amount of copper which would be required in the latter system, and the disadvantage of the third lead will be comparatively small, if any, for three leads of smaller size may perhaps be more convenient to place than two larger leads. When more machines have to be used there may be no disadvantage whatever connected with the third wire; however, since the simplicity of the generators and motors allows the use of higher electromotive forces, the cost of the leads may be reduced below the figure practicable with the direct current system.

Considering all the practical advantages offered by such an alternating system, I am of an opinion quite contrary to that of the author of the article in *Industries*, and think that it can quite successfully stand the competition of any direct current system, and this the more, the larger the machines built and the greater the distances.

Another case frequently occurring in practice is the transmission of small powers in numerous isolated places, such as mines, etc. In many of these cases simplicity and reliability of the apparatus are the principal objects. I believe that in many places of this kind my motor has so far proved a perfect success. In such cases a type of motor is used possessing great starting torque, requiring for its operation only alternating current and having no sliding contacts whatever on the armature, this advantage over other types of motors being highly valued in such places. The plant efficiency of this form of motor is, in the present state of perfection, inferior to that of the former form, but I am confident that improvements will be made in that direction. Besides, plant efficiency is in these cases of secondary importance, and in cases of transmission at considerable distances, it is no drawback, since the electromotive force may be raised as high as practicable on converters. I can not lay enough stress on this advantageous feature of my motors, and should think that it ought to be fully appreciated by engineers, for to high electromotive forces we are surely coming, and if they must be used, then the fittest apparatus will be employed. I believe that in the transmission of power with such commutatorless machines, 10,000 volts, and even more, may be used, and I would be glad to see Mr. Ferranti's enterprise succeed. His work is in the right direction, and, in my opinion, it will be of great value for the advancement of the art.

As regards the supply of power from large central stations in cities or centres of manufacture, the above arguments are applicable, and I see no reason why the three-wire motor system should not be successful. In putting up such a station, the third wire would be but a very slight drawback, and the system possesses enough advantages to over-balance this and any other disadvantage. But this question will be settled in the future, for as yet comparatively little has been done in that direction, even with the direct current system. The plant efficiency of such a three-wire system would be increased by using, in connection with the ordinary type of my motor, other types which act more like inert resistances. The plant efficiency of the whole system would, in all cases, be greater than that of each individual motor—if like motors are used—owing to the fact that they would possess different self-induction, according to the load.

The supply of power from lighting mains is, I believe, in the opinion of most engineers, limited to comparatively small powers, for obvious reasons. As the present systems are built on the two-wire plan, an efficient two-wire motor without commutator is required for this purpose, and also for traction purposes. A large number of these motors, embodying new principles, have been devised by me and are being constantly perfected. On lighting stations, however, my three-wire system may be advantageously carried out. A third wire may be run for motors and the old connections left undisturbed. The armatures of the generators may be rewound, whereby the output of the machines will be increased about 35 per cent., or even more in machines with cast iron field magnets. If the machines are worked at the same capacity, this means an increased efficiency. If power is available at the station, the gain in current may be used in motors. Those who object to the third wire, may remember that the old two-wire direct system is almost entirely superseded by the three-wire system, yet my

three-wire system offers to the alternating system relatively greater advantages, than the three-wire direct possesses over the two-wire. Perhaps, if the writer in *Industries* would have taken all this in consideration, he would have been less hasty in his conclusions.

New York, Sept. 17, 1890.

NIKOLA TESLA.

REPORTS OF COMPANIES.

WESTINGHOUSE AND PULLMAN INTERESTS.

With regard to various reports current on the subject, it now transpires that arrangements have been made between George Westinghouse, Jr., of Pittsburgh, and George M. Pullman, of Chicago, by which the Westinghouse Electric Mfg. Company will erect works conveniently close to the Pullman Palace Car Works, at Pullman, Ill., and the agreement reached, it is understood, is that the Pullman company will purchase all of their electric railway motors from the Westinghouse concern. The works to be erected are to cost between \$100,000 and \$500,000, and Mr. Westinghouse says 2000 men will be employed at the new shops. Work on the structures will probably begin next spring. That the immense works of Pullman's Palace Car Company and the big plant of the Westinghouse Company, at Pittsburgh, are to be consolidated both Messrs. Pullman and Westinghouse deny. Mr. Westinghouse further says that the erection of works at Pullman does not mean that the Pittsburgh business of the company is to be removed to Chicago. It will be merely an extension of their business. The works at Newark, N. J., Pittsburgh, New York City, etc., will also be continued as before.

DIVIDENDS.

THE EDISON GENERAL ELECTRIC Co. has declared its fourth quarterly dividend of 2 per cent.

STOCKS AND BONDS.

ROYAL ELECTRIC Co.—Application will be made to the Legislature of the Province of Quebec to change the value of the shares of the Royal Electric Co. from ten to one hundred dollars each.

FINANCIAL MARKET.

QUOTATIONS ON ELECTRICAL STOCKS.

Mr. F. Z. Maguire, Electrical Securities of 18 Wall street, this city, reports the following quotations of September 19th from New York, Boston and Washington:—

NEW YORK.

	BID.		BID.
W. U. Tel. Co.....	84½	Edison Gen. Elec. Co.....	39
American Tele. & Cable...	83	Edison Gen. Co. Def'd.....
Cent. & So. Amer.....	151	Consol'd Elec. Lt. Co.....	60
Mexican.....	205	Edison Ill'n'g Co. N. Y.....	481
Com. Cable Co.....	101½	U. S. Elec. Lt. Co.....	35
Postal Tel. Cable.....	39	North Am. Phonograph...	50

BOSTON.

	BID.		BID.
Thomson-Houston.....	51½	Ft. Wayne Co.....	111
" Pref'd.....	25½	Am. Bell.....	225½
" Series C.....	12	Erie.....	481
" " D.....	6	New England.....	51½
" Int. Co.....	Mexican.....	.90 cts
Thomson Welding Co.....	Trop. American.....
Thomson Eu. Welding.....	70	Edison Phon'gph Doll.....	2

WASHINGTON.

	BID.		BID.
Penna. Telephone.....	25	U. S. Elec. Lt. (Wash)....	170
Ches. & Pot. Telephone.....	71	Eck. & Sold. Home
Amer Graphophone.....	161	Elec. Ry.....	68

PITTSBURGH.

	BID.
Westinghouse Electric and Manufacturing Co.....	37½

LEGAL NOTES.

BRUSH ELECTRIC CO. VS. SPRAGUE ELEC. RY & MOTOR CO.

The Brush Electric Co. has brought an action in the U. S. circuit court against the Sprague Electric Railway and Motor Co. of New York, to restrain them from selling or using a certain dynamo electric machine on the ground of infringement. The complainants set forth in their bill that C. F. Brush was the original and first inventor of a new and useful improvement in dynamo electric machines, which was secured by letters patent. About Jan. 1, 1887, Mr. Brush assigned all his right, title and interest in said machines to complainants in this action, such assignment being duly recorded in the U. S. patent office.

The suit in question is based on the patent issued to Charles F. Brush, No. 260,652, dated July 4th, 1882, entitled Dynamo-Electric Machine. The claims cover the application of a copper sleeve surrounding the field magnets of a dynamo-electric machine, whereby the insulation of the magnets is preserved from the high potential of self-induction created by fluctuations in the exciting current. The device is no longer used on the street car motors of the defendants, who now claim that its employment makes the magnets sluggish and causes burning out of the armature by retarding the generation of counter-electromotive force in it.

A PRIZE SCHEME OF LIGHTING.

Mr. F. H. Whipple has been awarded a prize of \$100 at Davenport, Ia., for the best plan of lighting that city. Mr. Whipple, with native modesty, writes us from St. Louis that there was nothing special about the plans. Owing to the many hills and hollows in the town, it was difficult to light it economically. "There was nothing technical about it; but it was more the use of common sense in the location of lights."

TELEGRAPHY DURING THE COMMUNE.

One of the first things to be done after the recent disastrous fire at the New York offices of the Western Union Company was to re-establish the identity of each of the maze of wires running into the premises. Experienced electricians being on the spot, the task was not a very difficult one, and in a single day 300 circuits were restored. The ease with which this work was carried out at New York recalls to our mind, says *La Lumière Electrique*, a very instructive historic incident which occurred during the Commune. When the Republican Government quitted Paris, the operators at the central office in the Rue Granelle managed to mix up all the wires before leaving. The Communists were so ignorant of everything connected with telegraphy, that it was beyond their powers to unravel the wires; and during the whole time that they were in possession of the building, namely, from the end of March to the end of May, they were only able to use the military lines. M. Fabre de Lagrange, who was forced to accept the appointment of chief electrician to the Commune, took good care to keep the wires in confusion; and among other services to the State, he sent misleading telegrams, and thus saved many public and private buildings which the rebels wished to blow up by using an explosive mixture of air and coal-gas. These facts were clearly authenticated by the court-martial which tried M. Lagrange, and he was honorably acquitted.

THE TROUVE ELECTRIC ERYGMATOSCOPE.

At a recent meeting of the Académie des Sciences, M. G. Trouvé described an electrical appliance devised by him to facilitate the inspection of the geological strata pierced by the boring tool. The apparatus consists of a powerful incandescent lamp enclosed in a cylinder. One of the hemicylindrical surfaces of this cylinder constitutes the reflector; whilst the other, which is of thick glass, allows the luminous rays to pass through it, and light up the successive strata through which the lamp descends. At the base of the instrument there is an elliptical mirror, while the top is open, so as to enable an observer placed at the head of the boring and armed with suitable glasses to see on the mirror the reflected image of the stratum illuminated by the lamp, which is arranged so that its upward rays are intercepted. The whole apparatus is suspended from a cable formed by the two conducting wires. This cable is wound on a drum, the trunnions of which are insulated from one another and connected to the leads, current being obtained by two rubbing contacts attached to the poles of a portable battery. This arrangement enables the instrument to be raised and lowered without difficulty and without interrupting the observations. The erygmatoscope as at present arranged gives excellent results down to a depth of over 600 feet, and with a more powerful lamp it could be used at still greater depths. An expedition which has been sent out to the Mozambique coast by the Portuguese government, to search for coal beds and other mineral deposits, has been supplied with erygmatoscopes.

EXPERIMENTS WITH ALTERNATING CURRENTS
OF HIGH FREQUENCY.

BY

of Nicola Tesla

IN THE ELECTRICAL ENGINEER issue of 11th inst., I find a note of Prof. Elihu Thomson relating to some of my experiments with alternating currents of very high frequency.

Prof. Thomson calls the attention of your readers to the interesting fact that he has performed some experiments in the same line. I was not quite unprepared to hear this, as a letter from him has appeared in the *Electrician* a few months ago, in which he mentions a small alternate current machine which was capable of giving, I believe, 5,000 alternations per second, from which letter it likewise appears that his investigations on that subject are of a more recent date.

Prof. Thomson describes an experiment with a bulb enclosing a carbon filament which was brought to incandescence by the bombardment of the molecules of the residual gas when the bulb was immersed in water "rendered slightly conducting by salt dissolved therein," (?) and a potential of 1,000 volts alternating 5,000 time a second applied to the carbon strip. Similar experiments have, of course, been performed by many experimenters, the only distinctive feature in Prof. Thomson's experiment being the comparatively high rate of alternation. These experiments can also be performed with a steady difference of potential between the water and the carbon strip in which case, of course, conduction through the glass takes place, the difference of potential required being in proportion to the thickness of the glass. With 5,000 alternations per second, conduction still takes place, but the condenser effect is preponderating. It goes, of course, without saying that the heating of the glass in such a case is principally due to the bombardment of the molecules, partly also to leakage or conduction, but it is an undeniable fact that the glass may also be heated merely by the molecular displacement. The interesting feature in my experiments was that a lamp would light up when brought near to an induction coil, and that it could be held in the hand and the filament brought to incandescence.

Experiments of the kind described I have followed up for a long time with some practical objects in view. In connection with the experiment described by Prof. Thomson, it may be of interest to mention a very pretty phenomenon which may be observed with an incandescent lamp. If a lamp be immersed in water as far as practicable and the filament and the vessel connected to the terminals of an induction coil operated from a machine such as I have used in my experiments, one may see the dull red filament surrounded by a very luminous globe around which there is a less luminous space. The effect is probably due to reflection, as the globe is sharply defined, but may also be due to a "dark space;" at any rate it is so pretty that it must be seen to be appreciated.

Prof. Thomson has misunderstood my statement about the limit of audition. I was perfectly well aware of the fact that opinions differ widely on this point. Nor was I surprised to find that arcs of about 10,000 impulses per second, emit a sound. My statement "the curious point is," etc. was only made in deference to an opinion expressed by Sir William Thomson. There was absolutely no stress laid on the precise number. The popular belief was that something like 10,000 to 20,000 per second, or 20,000 to 40,000, at the utmost was the limit. For my argument this was immaterial. I contended that sounds of an incomparably greater number, that is, many times even the highest number, could be heard if they could be produced with sufficient power. My statement was only speculative, but I have devised means which I think may allow me to learn

something definite on that point. I have not the least doubt that it is simply a question of power. A very short arc may be silent with 10,000 per second, but just as soon as it is lengthened it begins to emit a sound. The vibrations are the same in number, but more powerful.

Prof. Thomson states that I am taking as the limit of "audition sounds from 5,000 to 10,000 complete waves per second." There is nothing in my statements from which the above could be inferred, but Prof. Thomson has perhaps not thought that there are two sound vibrations for each complete current wave, the former being independent of the direction of the current.

I am glad to learn that Prof. Thomson agrees with me as to the causes of the persistence of the arc. Theoretical considerations considerable time since have led me to the belief that arcs produced by currents of such high frequency would possess this and other desirable features. One of my objects in this direction has been to produce a practicable small arc. With these currents, for many reasons, much smaller arcs are practicable.

The interpretation by Prof. Thomson of my statements about the arc system leads me now, he will pardon me for saying so, to believe that what is most essential to the success of an arc system is a good management. Nevertheless I feel confident of the correctness of the views expressed. The conditions in practice are so manifold that it is impossible for any type of machine to prove best in all the different conditions.

In one case, where the circuit is many miles long, it is desirable to employ the most efficient machine with the least internal resistance; in another case such a machine would not be the best to employ. It will certainly be admitted that a machine of any type must have a greater resistance if intended to operate arc lights than if it is designed to supply incandescent lamps in series. When arc lights are operated and the resistance is small, the lamps are unsteady, unless a type of lamp is employed in which the carbons are separated by a mechanism which has no further influence upon the feed, the feeding being effected by an independent mechanism; but even in this case the resistance must be considerably greater to allow a quiet working of the lamps. Now, if the machine be such as to yield a steady current, there is no way of attaining the desired result except by putting the required resistance somewhere either inside or outside of the machine. The latter is hardly practicable, for the customer may stand a hot machine, but he looks with suspicion upon a hot resistance box. A good automatic regulator of course improves the machine and allows us to reduce the internal resistance to some extent, but not as far as would be desirable. Now, since resistance is loss, we can advantageously replace resistance in the machine by an equivalent impedance. But to produce a great impedance with small ohmic resistance, it is necessary to have self-induction and variation of current, and the greater the self-induction and the rate of change of the current, the greater the impedance may be made, while the ohmic resistance may be very small. It may also be remarked that the impedance of the circuit external to the machine is likewise increased. As regards the increase in ohmic resistance in consequence of the variation of the current, the same is, in the commercial machines now in use, very small. Clearly then a great advantage is gained by providing self induction in the machine circuit and undulating the current, for it is possible to replace a machine which has a resistance of, say, 16 ohms by one which has no more than 2 or 3 ohms, and the lights will work even steadier. It seems to me therefore, that my saying that self-induction is essential to the commercial success of an arc system is justified. What is still more important, such a machine will cost considerably less. But to realize fully the benefits, it is preferable to employ an alternate current machine, as in this case a greater rate of change in the current is obtainable. Just what the ratio of resistance to impedance is in the Brush and Thomson

machines is nowhere stated, but I think that it is smaller in the Brush machine, judging from its construction.

As regards the better working of clutch lamps with undulating currents, there is, according to my experience, not the least doubt about it. I have proved it on a variety of lamps to the complete satisfaction not only of myself, but of many others. To see the improvement in the feed due to the jar of the clutch at its best it is desirable to employ a lamp in which an independent clutch mechanism effects the feed, and the release of the rod is independent of the up and down movement. In such a lamp the clutch has a small inertia and is very sensitive to vibration, whereas, if the feed is effected by the up and down movement of the lever carrying the rod, the inertia of the system is so great that it is not affected as much by vibration, especially if, as in many cases, a dash pot is employed. During the year 1885 I perfected such a lamp which was calculated to be operated with undulating currents. With about 1,500 to 1,800 current impulses per minute the feed of this lamp is such that absolutely no movement of the rod can be observed, even if the arc be magnified fifty-fold by means of a lens; whereas, if a steady current is employed, the lamp feeds by small steps. I have, however, demonstrated this feature on other types of lamps, among them being a derived circuit lamp such as Prof. Thomson refers to. I conceived the idea of such a lamp early in 1884, and when my first company was started, this was the first lamp I perfected. It was not until the lamp was ready for manufacture that, on receiving copies of applications from the Patent Office, I learned for the first time, not having had any knowledge of the state of the art in America, that Prof. Thomson had anticipated me and had obtained many patents on this principle, which, of course, greatly disappointed and embarrassed me at that time. I observed the improvement of the feed with undulating currents on that lamp, but I recognized the advantage of providing a light and independent clutch unhampered in its movements. Circumstances did not allow me to carry out at that time some designs of machines I had in mind, and with the existing machines the lamp has worked at a great disadvantage. I cannot agree with Prof. Thomson that small vibrations would benefit a clockwork lamp as much as a clutch lamp; in fact, I think that they do not at all benefit a clockwork lamp.

It would be interesting to learn the opinion of Mr. Charles F. Brush on these points.

Prof. Thomson states that he has run with perfect success clutch lamps "in circuit with coils of such large self-induction that any but very slight fluctuations were wiped out." Surely Prof. Thomson does not mean to say that self-induction wiped out the periodical fluctuations of the current. For this, just the opposite quality, namely, capacity, is required. The self-induction of the coils in this case simply augmented the impedance and prevented the great variations occurring at large time intervals, which take place when the resistance in circuit with the lamps is too small, or even with larger resistance in circuit when the dash pots either in the lamps or elsewhere are too loose.

Prof. Thomson further states that in a lamp in which the feed mechanism is under the control of the derived circuit magnet only, the fluctuations pass through the arc without affecting the magnet to a perceptible degree. It is true that the variations of the resistance of the arc, in consequence of the variations in the current strength, are such as to dampen the fluctuation. Nevertheless, the periodical fluctuations are transmitted through the derived circuit, as one may convince himself easily of, by holding a thin plate of iron against the magnet.

In regard to the physiological effects of the currents I may state that upon reading the memorable lecture of Sir William Thomson, in which he advanced his views on the propagation of the alternate currents through conductors, it instantly occurred to me that currents of high frequencies would be less injurious. I have been looking for a

proof that the mode of distribution through the body is the cause of the smaller physiological effects. At times I have thought to have been able to locate the pain in the outer portions of the body, but it is very uncertain. It is most certain, however, that the feeling with currents of very high frequencies is somewhat different from that with low frequencies. I have also noted the enormous importance of one being prepared for the shock or not. If one is prepared, the effect upon the nerves is not nearly as great as when unprepared. With alternations as high as 10,000 per second and upwards, one feels but little pain in the central portion of the body. A remarkable feature of such currents of high tension is that one receives a burn instantly he touches the wire, but beyond that the pain is hardly noticeable.

But since the potential difference across the body by a given current through it is very small, the effects can not be very well ascribed to the surface distribution of the current, and the excessively low resistance of the body to such rapidly varying currents speak rather for a condenser action.

In regard to the suggestion of Dr. Tatum, which Prof. Thomson mentions in another article in the same issue, I would state that I have constructed machines up to 480 poles, from which it is possible to obtain about 30,000 alternations per second, and perhaps more. I have also designed types of machines in which the field would revolve in an opposite direction to the armature, by which means it would be possible to obtain from a similar machine 60,000 alternations per second or more.

I highly value the appreciation of Prof. Thomson of my work, but I must confess that in his conclusion he makes a most astounding statement as to the motives of his critical remarks. I have never for a moment thought that his remarks would be dictated by anything but friendly motives. Often we are forced in daily life to represent opposing interests or opinions, but surely in the higher aims the feelings of friendship and mutual consideration should not be affected by such things as these.

WRIGHT AND WILSON'S INDUCTION PREVENTER FOR TELEPHONES.

The accompanying illustration represents a device for which the inventors, Messrs. Thomas F. Wright and Ed. G. Wilson, of Chicago, claim prevents the disturbing

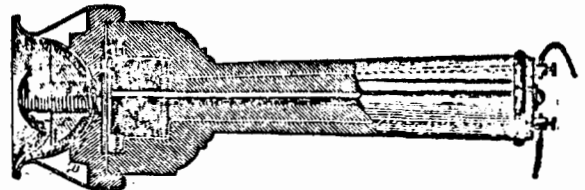

WRIGHT AND WILSON'S INDUCTION PREVENTER.

effects of induction. The device is intended for attachment to the ordinary receivers now in use, and consists of a casing of sheet metal, having the external appearance of a small cup which fits snugly within the concavity in the end of the receiver, the interior being concaved around the edges of the cup and provided with a central projecting dome intended to fit against and within the ear.

The two walls of the casing are provided with central perforations *c* *b*, between which a passage is formed by the insertion of a tube *E* composed of a coil of small steel wire. Surrounding this tube, but enclosed within the casing, is a spool *F*, grooved externally, as shown, and wound with a coil of fine copper wire, one end of which is driven into the spool, while the free end terminates immediately in front of, but out of contact with, the diaphragm of the telephone-receiver.

This induction-preventing device is attached to the receiver by the spring hook attached to the casing which engages the usual flange upon the end of the receiver.

The Electrical Engineer - London
April 3, 1891, p. 345

ALTERNATE CURRENT MOTORS

Sir - In your issue of March 6 I find the passage: "Mr. Kapp described the position as it exists. He showed how Ferraris first of all pointed out the right way to get an alternating-current motor that was self-starting, and how Tesla and others had worked in the direction indicated by Ferraris," etc.

I would be very glad to learn how Mr. Kapp succeeded in showing this. I may call his attention to the fact that the date of filing of my American patent anticipates the publication of the results of Prof. Ferraris in Italy by something like six months. The date of filing of my application is, therefore, the first public record of the invention. Considering this fact, it seems to me that it would be desirable that Mr. Kapp should modify his statement. - Yours, etc.

NIKOLA TESLA
New York, 17th March , 1891.

Electrical Review - London
April 3, 1891, p. 446.

CORRESPONDENCE.

Electro-motors.

Fifteen or sixteen years ago, when I was pursuing my course at the college, I was told by an eminent physicist that a motor could not be operated without the use of brushes and commutators, or mechanical means of some kind for commutating the current. It was then I determined to solve the problem.

After years of persistent thought I finally arrived at a solution. I worked out the theory to the last detail, and confirmed all of my theoretical conclusions by experiments. Recognising the value of the invention, I applied myself to the work of perfecting it, and after long continued labour I produced several types of practical motors.

Now all this I did long before anything whatever transpired in the whole scientific literature—as far as it could be ascertained—which would have even pointed at the possibility of obtaining such a result, but quite contrary at a time when scientific and practical men alike considered this result unattainable. In all civilised countries patents have been obtained almost without a single reference to anything which would have in the least degree rendered questionable the novelty of the invention. The first published essay—an account of some laboratory experiments by Prof. Ferraris—was published in Italy six or seven months after the date of filing of my applications for the foundation patents. The date of filing of my patents is thus the first public record of the invention. Yet in your issue of March 6th I read the passage: "For several years past, from the days of Prof. Ferraris's investigations, which were followed by those of Tesla, Zipernowsky and a host of imitators," &c.

No one can say that I have not been free in acknowledging the merit of Prof. Ferraris, and I hope that my statement of facts will not be misinterpreted. Even if Prof. Ferraris's essay would have anticipated the date of filing of my application, yet, in the opinion of all fair-minded men, I would have been entitled to the credit of having been the first to produce a practical motor; for Prof. Ferraris himself denies in his essay the value of the invention for the transmission of power, and only points out the possibility of using a properly-constructed generator, which is the only way of obtaining the required difference of phase without losses; for even with condensers—by means of which it is possible to obtain a quarter phase—there are considerable losses, the cost of the condensers not considered.

Thus, in the most essential features of the system—the generators with the two or three circuits of differing phase, the three-wire system, the closed coil armature, the motors with direct current in the field, &c.—I would stand alone, even had Prof. Ferraris's essay been published many years ago.

As regards the most practicable form of two-wire motor, namely, one with a single energising circuit and induced circuits, of which there are now thousands in use, I likewise stand alone.

Most of these facts, if not all, are perfectly well known in England; yet, according to some papers, one of the leading English electricians does not hesitate to say that I have worked in the direction indicated by Prof. Ferraris, and in your issue above referred to it seems I am called an imitator.

Now, I ask you where is that world-known English fairness? I am a pioneer, and I am called an imitator. I am not an imitator. I produce original work or none at all.

Nikola Tesla.

New York, *March 17th*, 1891.

Letters to the Editor.

PHENOMENA OF CURRENTS OF HIGH FREQUENCY.

I cannot pass without comment the note of Prof. Thomson in your issue of April 1, although I dislike very much to engage in a prolonged controversy. I would gladly let Prof. Thomson have the last word, were it not that some of his statements render a reply from me necessary.

I did not mean to imply that, whatever work Prof. Thomson has done in alternating currents of very high frequency, he had done subsequent to his letter published in the *Electrician*. I thought it possible, and even probable, that he had made his experiments some time before, and my statement in regard to this was meant in this general way. It is more than probable that quite a number of experimenters have built such machines and observed effects similar to those described by Prof. Thomson. It is doubtful, however, whether, in the absence of any publication on this subject, the luminous phenomena described by me have been observed by others, the more so, as very few would be likely to go to the trouble I did, and I would myself not have done so had I not had beforehand the firm conviction, gained from the study of the works of the most advanced thinkers, that I would obtain the results sought for. Now, that I have indicated the direction, many will probably follow, and for this very purpose I have shown some of the results I have reached.

Prof. Thomson states decisively in regard to experiments with the incandescent lamp bulb and the filament mounted on a single wire, that he cannot agree with me at all that conduction through the glass has anything to do with the phenomenon observed. He mentions the well-known fact that an incandescent lamp acts as a Leyden jar and says that "if conduction through the glass were a possibility this action could not occur." I think I may confidently assert that very few electricians will share this view. For the possibility of the condenser effect taking place it is only necessary that the rate at which the charges can equalize through the glass by conduction should be somewhat below the rate at which they are stored.

Prof. Thomson seems to think that conduction through the glass is an impossibility. Has he then never measured insulation resistance, and has he then not measured it by means of a conduction current? Does he think that there is such a thing as a perfect non-conductor among the bodies we are able to perceive? Does he not think that as regards conductivity there can be question only of degree? If glass were a perfect non-conductor, how could we account for the leakage of a glass condenser when subjected to steady differences of potential?

While not directly connected with the present controversy, I would here point out that there exists a popular error in regard to the properties of dielectric bodies. Many electricians frequently confound the theoretical dielectric of Maxwell with the dielectric bodies in use. They do not stop to think that the only perfect dielectric is ether, and that all other bodies, the existence of which is known to us, must be conductors, judging from their physical properties.

My statement that conduction is concerned to some, although perhaps negligible, extent in the experiment above described was, however, made not only on account of the fact that all bodies conduct more or less, but principally on account of the heating of the glass during the experiment. Prof. Thomson seems to overlook the fact that the insulating power of glass diminishes enormously with the increase in temperature, so much so, that melted glass is comparatively an excellent conductor. I have, moreover, stated in my first reply to Prof. Thomson in your issue of March 18, that the same experiment can be performed by means of an unvarying difference of potential. In this case it must be assumed that some such process as conduction through the glass takes place, and all the more as it is possible to show by experiment, that with a sufficiently high steady difference of potential, enough current can be passed through the glass of a condenser with mercury coating to light up a Geissler tube joined in series with the condenser. When the potential is alternating, the condenser action comes in and conduction becomes insignificant, and, the more so, the greater the rate of alternation or change per unit of time. Nevertheless, in my opinion, conduction must always exist, especially if the glass is hot, though it may be negligible with very high frequencies.

Prof. Thomson states, further, that from his point of view I have misunderstood his statement about the limit of audition. He says that 10,000 to 20,000 alternations correspond to 5,000 to 10,000 complete waves of sound. In my first reply to Prof. Thomson's remarks (in your issue of March 18,) I avoided pointing out directly that Prof. Thomson was mistaken, but now I see no way out of it. Prof. Thomson will pardon me if I call his attention to the fact he seems to disregard, namely, that 10,000 to 20,000 alternations of current in an arc—which was the subject under discussion—do not mean 5,000 to 10,000, but 10,000 to 20,000 complete waves of sound.

He says that I have adopted or suggested as the limit of audition

10,000 waves per second, but I have neither adopted nor suggested it. Prof. Thomson states that I have been working with 5,000 to 10,000 complete waves, while I have nowhere made any such statement. He says that this would be working below the limit of audition, and cites as an argument that at the Central High School, in Philadelphia, he has heard 20,000 waves per second; but he wholly overlooks a point on which I have dwelt at some length, namely, that the limit of audition of an arc is something entirely different from the limit of audition in general.

Prof. Thomson further states, in reply to some of my views expressed in regard to the constant current machines that five or six years ago it occurred to him to try the construction of a dynamo for constant current, in which "the armature coils were of a highly efficient type, that is, of comparatively short wire length for the voltage and moving in a dense magnetic field." Exteriorly to the coils and to the field he had placed in the circuit of each coil an impedance coil which consisted of an iron core wound with a considerable length of wire and connected directly in circuit with the armature coil. He thus obtained, he thought, "the property of considerable self-induction along with efficient current generation." Prof. Thomson says he expected "that possibly the effects would be very much the same as those obtainable from the regularly constructed apparatus." But he was disappointed, he adds. With all the consideration due to Prof. Thomson, I would say that, to expect a good result from such a combination, was rather sanguine. Earth is not farther from Heaven than this arrangement is from one, in which there would be a length of wire, sufficient to give the same self-induction, wound on the armature and utilized to produce useful E. M. F., instead of doing just the opposite, let alone the loss in the iron cores. But it is, of course, only fair to remember that this experiment was performed five or six years ago, when even the foremost electricians lacked the necessary information in these and other matters.

Prof. Thomson seems to think that self-induction wipes out the periodical undulations of current. Now self-induction does not produce any such effect, but, if anything, it renders the undulation more pronounced. This is self-evident. Let us insert a self-induction coil in a circuit traversed by an undulating current and see what happens. During the period of the greatest rate of change, when the current has a small value, the self-induction opposes more than during the time of the small rate of change when the current is at, or near, its maximum value. The consequence is, that with the same frequency the maximum value of the current becomes the greater, the greater the self-induction. As the sound in a telephone depends only on the maximum value, it is clear that self-induction is the very thing required in a telephone circuit. The larger the self-induction, the louder and clearer the speech, provided the same current is passed through the circuit. I have had ample opportunity to study this subject during my telephone experience of several years. As regard the fact that a self-induction coil in series with a telephone diminishes the loudness of the sound, Prof. Thomson seems to overlook the fact that this effect is wholly due to the impedance of the coil, *i. e.*, to its property of diminishing the current strength. But while the current strength is diminished the undulation is rendered only more pronounced. Obviously, when comparisons are made they must be made with the same current.

In an arc machine, such as that of Prof. Thomson's, the effect is different. There, one has to deal with a make and break. There are then two induced currents, one in the opposite, the other in the same direction with the main current. If the function of the mechanism be the same whether a self-induction coil be present or not, the undulations could not possibly be wiped out. But Prof. Thomson seems, likewise, to forget that the effect is wholly due to the defect of the commutator; namely, the induced current of the break, which is of the same direction with the main current and of great intensity, when large self-induction is present, simply bridges the adjacent commutator segments, or, if not entirely so, at least shortens the interval during which the circuit is open and thus reduces the undulation.

In regard to the improvement in the feeding of the lamps by vibrations or undulations, Prof. Thomson expresses a decisive opinion. He now says that the vibrations *must* improve the feeding of a clock-work lamp. He says that I "contented myself by simply saying," that I cannot agree with him on that point.

Now, saying *it*, is not the only thing I did. I have passed many a night watching a lamp feed, and I leave it to any skilled experimenter to investigate whether my statements are correct. My opinion is, that a clock-work lamp; that is, a lamp in which the descent of the carbon is regulated not by a clutch or friction mechanism, but by an escapement, cannot feed any more perfectly than tooth by tooth, which may be a movement of, say, $\frac{1}{4}$ of an inch or less. Such a lamp will feed in nearly the same manner whether the current be perfectly smooth or undulating, providing the conditions of the circuit are otherwise stable. If there is any advantage, I think it would be in the use of a smooth current, for, with an undulating current, the lamp is likely to miss some time and feed by more than one tooth. But in a lamp in which the descent of the carbon is regulated by friction mechanism, an undulating current of the proper number of undulations per second will always give a better result. Of course, to

realize fully the benefits of the undulating current the release ought to be effected independently of the up-and-down movement I have pointed out before.

In regard to the physiological effects, Prof. Thomson says, that in such a comparatively poor conductive material as animal tissue the distribution of current cannot be governed by self-induction to any appreciable extent, but he does not consider the two-fold effect of the large cross-section, pointed out by Sir William Thomson. As the resistance of the body to such currents is low, we must assume either condenser action or induction of currents in the body.

NEW YORK, April 4, 1891.

NIKOLA TESLA.

Literature.

The Elements of Dynamic Electricity and Magnetism: By Philip Atkinson, A. M., Ph. D. New York: D. Van Nostrand Co., 1891. 5x8 inches; 405 pages. Price, \$2.

While there is no lack of books on the elements of electricity and magnetism, there has of late arisen a demand for a class of works which shall be adapted not only to the learner who desires to continue his studies with special reference to their future application in actual work, but also for that large class which has come to take a lively interest in electrical work, because it has been so forcibly brought to public attention during the last few years. A book to interest these learners and general readers, therefore, must present the subjects in their plainest dress, and must convey the facts through the medium of conclusive inductive reasoning rather than by the aid of formulæ. It is from this standpoint that the author has treated the subject matter contained in the book, which forms a companion work to that previously published, entitled "Elements of Static Electricity." In the present work the author has taken up the subject of dynamo electricity and magnetism, and very properly begins with definitions and a description of the voltaic battery. He describes the principal single and double fluid cells now in common use, and their method of operation. Two chapters on magnetism and electro-magnetism discuss the wide range of these phenomena. The author leads up from the natural magnet to the mariner's and surveyor's compass and gives one of the most complete short exposures of terrestrial magnetism that has come under our observation. He also discusses the form of magnets, and their polar attraction and repulsion. Passing on to electro-magnetism, we find a treatment of the laws governing the relation between currents carried in neighboring conductors and the effects of currents upon magnets and upon masses of iron. The author explains very clearly the simple rules by which all these phenomena may be remembered, and shows their application to the construction of the Ruhmkorff coil, which is described very fully.

Chapter VI is devoted to electric measurement. In it are described the various electrical units employed in practical electrical work, and this is followed by a description of the most generally employed testing instruments, among them the Thomson galvanometer, the Weston voltmeter, the Wirt voltmeter, the Cardew and others. The dynamo and motor are then taken up, and after a few short introductory paragraphs on the history of the dynamo, the author at once brings us to the types employed at the present time and their construction. This survey includes not only those of the well-known continuous current machines, but also the best known alternating current dynamos and motors. Thermo-magnetic motors are also touched upon here. Electrolysis and electric storage form the subject matter of the two following chapters, introduced by the theory of Grothuss, which still seems to be the favorite one for text book purposes, and perhaps justly so. The application of the laws of electrolysis to electric storage is also pointed out, and the construction of the most recent types of secondary batteries is described and illustrated. The relations of electricity to heat form a chapter which will attract considerable interest as we find in it, besides the laws governing the generation of heat in conductors, a simple statement of electro-thermic phenomena and a description of the latest forms of the Thomson welding machine, and the results which have been obtained with it. The relation of electricity to light forms the subject matter of Chapter XI, in which the various phenomena of the effects of light on selenium are described, together with the magneto-optic polarization effects, and the various other photo-electric phenomena discovered by Becquerel, Kerr and others. The author then takes up the arc light and discusses its nature, and the most general types of lamps employed. This is followed by similar treatment of the incandescent lamp, in which connection the two and three wire systems of distribution are described. The telegraph and the telephone, to each of which a chapter is devoted, end the volume.

While we are not prepared to agree entirely with all the views expressed by the author, especially on points of theory, the present unsettled state of the latter might be easily made to account for divergences. If we may also be allowed to suggest, we think that the work in further editions, which will undoubtedly be called for, might be improved by a more rigid adherence

to the classification of the subjects treated. The book has the undoubted merit of giving the latest information on the practical advances made, and does not burden the reader with a long and profitless review of what has been done during the last fifty years. The book is admirably printed and illustrated, and the author has evidently availed himself of the latest and best sources of information. We trust that the publishers will find their enterprise fully rewarded.

THE SWINBURNE TRANSFORMERS.

In my letter appearing in your last issue an error was made in the statement beginning: "In the communication from Mr. Swinburne a few days after the publishing of my article, Mr. Swinburne, etc." It should read as follows: "In a communication received from Messrs. Swinburne & Co. a few days after the publishing of my article, etc., they state that the leakage current in their transformers of 40 lights capacity is about 40 per cent.; allowing that this 40 per cent. is correct, the comparative leakage current in the open and closed types of transformers is approximately 10 to 1."

WM. STANLEY, JR.

PITTSFIELD, MASS.

WHAT ARE THE LIMITS OF HIGH POTENTIAL TRANSMISSION?

In another column we describe the tests which have recently been made to demonstrate the possibility of transmitting electrical energy between Lauffen and Frankfort, in which potentials of over 30,000 volts were employed. These experiments appeared to indicate the practical success of the system, but in a letter appearing in the *Elektrotechnische Zeitschrift*, August Schnell, of The Hague, Holland, draws attention to certain points, which, he claims, have not been fully considered. He writes as follows:

"In our technical papers, the power transmission project from Lauffen to Frankfort, on the occasion of the Frankfort Exhibition, has been the frequent object of discussion of late. Although in the carrying out of my experiments in the preparation of ozone, I have already had considerable experience with alternating currents up to 24,000 volts potential, I have up to now avoided taking part in this discussion. Since, however, this project has been seriously taken up and spoken of by his Excellency, Dr. Von Stephan, I have regarded it as my duty to testify to the enormous difficulties of transmitting power with 20,000 volts alternating current, which make its carrying out in practice impossible. The transmitted 300 h. p. may have at the primary transformer 30,000 volts and 6.2 amperes=186,000 watts. To obtain 30,000 volts by transformation in commercially practicable apparatus, so as to be safe, is indeed difficult, but under certain construction not impossible.

"The chief difficulty in the transmission of 30,000 volts lies not, however, in the fourfold transformation and the loss thereby entailed, nor in the transformers themselves, but in the outside conductors. With 6.2 amperes, with a copper wire of 5 mm. diameter, and with 350 kilometres of wire the drop in potential amounts to only 1,830 volts=6.1 per cent.; but the other losses which the conductors are subject to have been entirely left out of account up to the present. For the overhead conductors telegraph poles are necessary, which ought not to be more than 50 metres apart, so that altogether there will be 3,500 telegraph poles, and 7,000 oil insulators. One insulator, even an oil insulator, has an average resistance of 1,000 megohms when measured with low potential battery current. For 7,000 insulators there may then be a resistance of 150,000 ohms; then there would be, at 30,000 volts, 0.2 ampere loss, which loss of 3.2 per cent., in such an important undertaking, may almost be neglected.

"Now, however, comes the principal point: The 'charging loss,' according to my measurements, for an air dry insulator at 15,000 volts, amount to 2.3 watts; at 20,000 volts to 4.7 watts, and at 30,000 volts might reach about 15 watts. In the 7,000 insulators then, in dry weather, there would be about 100,000 watts loss. The losses in foggy or rainy weather are still left quite out of the calculation. If we assume a distance between the parallel conductors of one metre, there results, at 30,000 volts potential, a loss of 0.15 watt per metre by silent discharge; hence, for 175 kilometres, a loss of 26,000 watts. Allowing an efficiency of 95 per cent. for the primary and secondary machines and 98 per cent. for the transformers at full load, the loss in the line 6.1 per cent., the insulation loss 3.2 per cent., the 'charging loss' on the insulators at 100,000 watts, and the silent discharge in 175 kilometres of parallel conductors at 26,000 watts, then we come to the conclusion that in dry weather, from the Lauffen plant of 300 h. p. we will get in Frankfort about 37 h. p.

"There must be taken into account still further, about 6,000 square metres of condensing surface of the conductors and insulators. I have measured the sparking distance with 20,000 volts alternating current at 100 reversals per second, without any condenser, and found it to be 46 mm.; and when a condenser of 15 sq. mm. surface was included, the sparking distance was more than 80 mm.; but how great the sparking distance is with 6,000 square metres of condensing surface, goes beyond my experience. On the basis of these truths it is easily seen that the whole project is a technical impossibility."

The Electrical World - N. Y.
Oct. 8, 1892, p. 222.

The "Drehstrom" Patent.

BY NIKOLA TESLA.

In the last issue of *THE ELECTRICAL WORLD* I find an article on my "Drehstrom" patent which appeared originally in *Industries*, and is, I believe, from the pen of the able editor of that journal. Some of the statements made are such as to cause an erroneous opinion to gain ground, which I deem it my duty to prevent—a disagreeable one I may say, as I do not like to express my opinion on a patent, especially if it is my own.

It may be, as the writer states, that the theory of the action of my motor advanced in my paper before the American Institute in May, 1888, is a clumsy one, but this theory was formed by me a number of years before the practical results were announced, the patents being applied for only after it was undoubtedly demonstrated that the motor could fairly compete in efficiency with the direct current motor, and that the invention was one of commercial value. These patents were taken out with the help of some of the ablest attorneys in the United States, well versed in electrical matters; the specifications were drawn up with great care, in view of the importance of the invention, and with proper regard to the state of the art at that period, and had the patents been carefully studied by others there would not have been various features of my system reinvented, and several inventors would have been spared at this late date a keen disappointment.

The writer apprehends that it might be difficult for a non-technical judge to decide whether a motor with two or more separate fields and armatures, coupled together mechanically, does or does not fall under my patent. I do not share his apprehension. Judges are highly educated men, and it does not require much technical knowledge to convince one that it is the same whether two belts driving a rigid arbor are close together or far apart. Nor do I think that it is necessary for the honorable judge to be a partisan of the armature reaction theory in order to recognize the identity of the two arrangements referred to by the writer of the article in question. Indeed, I would seriously doubt the sincerity of a man capable of clear conceptions were he to uphold that the arrangements are essentially different, even if the case should stand exactly as he assumes by way of illustration of "puzzles likely to arise." For where is there a difference? Take, for instance, a form of my two-phase motor. There are two sets of field magnets, one at the *neutral* parts of the other. One of the sets, therefore, might as well be removed and placed a distance sideways, but long experience shows that in output, efficiency, cost of construction and in general mechanical respects such an arrangement is inferior. The two sets are connected inductively through the armature body or the windings thereon. Part of the period one set of field magnets acts as a generator, setting up induction currents, which circulate in the field of force of the other set, which may be looked upon as a motor. Part of the period again, the second set becomes the generator and the first the motor, the action being at the same time such that the generated currents are always passed in a definite direction with respect to the field; they are commutated as it were, and a tendency to rotate in a given direction is imparted to the armature. Now place two fields side by side and connect properly the armature windings. Are not the fields again inductively connected? Do not the currents set up by one field cause currents to circulate in the other, and is the action not exactly the same in both cases? This is a fact,

no matter what theory is adhered to. The writer says that in the case of two separate structures there is really nothing which may be called rotation of the field. But is there any such thing, when the two structures are merged in one? Is it not in accordance with accepted notions to conceive the imaginary lines as surging simply in the pole projections in exactly the same manner in both the arrangements? Irrespective of the view taken, be it even the more unfair to the inventor, no one is permitted to go so far as to make him responsible, in such a case, for theories and interpretations of his invention. Theories may come and go, but the motor works, a practical result is achieved and the art is advanced through his pains and efforts. But what I desire to point out principally is that in the article above referred to the writer is only assuming a case which cannot occur. He is evidently judging the state of things from my short paper before the American Institute. This paper was written in a hurry, in fact only shortly before the meeting of the Institute, and I was unable to do full justice even to those features upon which, as employé of a company owning the invention, I was permitted to dwell. Allow me to observe that my patent specification was written up more carefully than my paper and the view taken in it is a broader and truer one. While the "clumsy" theory was adapted as the best in explanation of the action of the motor, the invention is *not* represented as dependent entirely on that theory; and in showing a three phase motor with six projections, where it was manifestly more consistent with the accepted popular ideas to assume the "lines of force" as simply surging in the projecting pole pieces, this view was distinctly and advisedly taken, as the following quotation from my foundation patent will show: "The variations in the strength and intensity of the currents transmitted through these circuits (lines and armature) and traversing the coils of the motor produce a steadily progressive shifting of the *resultant attractive force* exerted by the poles upon the armature and consequently keep the armature rapidly rotating." There is, in this instance, no question of a rotating field in the common acceptance of the term of the *resultant attractive force*: there is a question simply of a diagram of force, and it is immaterial for the operation whether the fields are close together or far apart, or even whether, or not, they are inductively connected.

I do not think that in Germany, where the Patent Office is proverbially strict in upholding the rights of the inventor, an illegitimate and unfair appropriation of the invention by others will be tolerated by the courts.

Reprinted with Permission. Reprinted from Oct. 8, 1892, issue of *Electrical World*. © Copyright 1892, McGraw-Hill, Inc. All rights reserved.

Electrician - London
Dec. 17, 1892, p. 391.

THE EWING HIGH-FREQUENCY ALTERNATOR AND PARSONS STEAM ENGINE

In your issue of November 18 I find a description of Prof. Ewing's high-frequency alternator, which has pleased me chiefly because it conveyed to me the knowledge that he, and with him, no doubt, other scientific men, is to investigate the properties of high-frequency currents. With apparatus such as you describe, shortly a number of experimenters, more competent than myself, will be enabled to go over the ground as yet but imperfectly explored, which will undoubtedly result in the observation of novel facts and elimination of eventual errors.

I hope it will not be interpreted as my wishing to detract anything from Prof. Ewing's merit if I state the fact that for a considerable time past I have likewise thought of combining the identical steam turbine with a high-frequency alternator. *Anch' io sono pittore.* I had a number of designs with such turbines, and would have certainly carried them out had the turbines been here easily and cheaply obtainable, and had my attention not been drawn in a different direction. As to the combination to which you give a rather complicated name, I consider it an excellent one. The advantages of using a high speed are especially great in connection with such alternators. When a belt is used to drive, one must resort to extraordinarily large diameters in order to obtain the necessary speed, and this increases the difficulties and cost of construction in an entirely unreasonable proportion. In the machine used in my recent experiments the weight of the active parts is less than 50 pounds, but there is an additional weight of over 100 pounds in the supporting frame, which a very careful constructor would have probably made much heavier. When running at its maximum speed, and with a proper capacity in the armature circuit, two and a one-half horse-power can be performed. The large diameter (30 inches), of course, has the advantage of affording better facility for radiation; but, on the other hand, it is impossible to work with a very small clearance.

I have observed with interest that Prof. Ewing has used a magnet with alternating poles. In my first trials I expected to obtain the best results with a machine of the Mordey type - that is, with one having pole projections of the same polarity. My idea was to energize the field up to the point of the maximum permeability of the iron and vary the induction around that point. But I found that with a very great number of pole projections such a machine would not give good results, although with few projections, and with an armature without iron, as used by Mordey, the results obtained were excellent. Many experiences of similar nature made in the course of my study demonstrate that the ordinary rules for the magnetic circuit do not hold good with high frequency currents. In ponderable matter magnetic permeability, and also specific inductive capacity, must undergo considerable change when the frequency is varied within wide limits. This would render very difficult the exact determination of the energy dissipated in iron cores by very rapid cycles of magnetization, and of that in conductors and condensers, by very quick reversals of current. Much valuable work remains to be done in these fields, in which it is so easy to observe novel phenomena, but so difficult to make quantitative determinations. The results of Prof. Ewing's systematical research will be awaited with great interest.

It is gratifying to note from his tests that the turbines are being rapidly improved. Though I am aware that the majority of engineers do not favor their adoption. I do not hesitate to say that I believe in their success. I think their principle uses, in no distant future, will be in connection with alternate current motors, by means of which it is easy to obtain a constant and, in any desired ratio, reduced speed. There are objections to their employment for driving direct current

generators, as the commutators must be a source of some loss and trouble, on account of the very great speed; but with an alternator there is no objectionable feature whatever. No matter how much one may be opposed to the introduction of the turbine, he must have watched with surprise the development of this curious branch of the industry, in which Mr. Parsons has been a pioneer, and everyone must wish him the success which his skill has deserved.

Nikola Tesla

THE

Electrical Engineer.

VOL. XIV.

DECEMBER 21, 1892.

No. 242.

ON THE DISSIPATION OF THE ELECTRICAL ENERGY OF THE HERTZ RESONATOR.

BY

Nikola Tesla



ANYONE who, like myself, has had the pleasure of witnessing the beautiful demonstrations with vibrating diaphragms which Prof. Bjerknes, exhibited in person at the Paris Exposition in 1889, must have admired his ability and painstaking care to such a degree, as to have an almost implicit faith in the correctness of observations made by him. His experiments "On the Dissipation of the Electrical Energy of the Hertz Resonator," which are described in the issue of Dec. 14, of THE ELECTRICAL ENGINEER, are prepared in the same ingenious and skillful manner, and the conclusions drawn from them are all the more interesting as they agree with the theories put forth by the most advanced thinkers. There can not be the slightest doubt as to the truth of these conclusions, yet the statements which follow may serve to explain in part the results arrived at in a different manner; and with this object in view I venture to call attention to a condition with which, in investigations such as those of Prof. Bjerknes, the experimenter is confronted.

The apparatus, oscillator and resonator, being immersed in air, or other discontinuous medium, there occurs—as I have pointed out in the description of my recent experiments before the English and French scientific societies—dissipation of energy by what I think might be appropriately called *electric sound-waves* or *sound-waves of electrified air*. In Prof. Bjerknes's experiments principally this dissipation in the resonator need be considered, though the sound-waves—if this term be permitted—which emanate from the surfaces at the oscillator may considerably affect the observations made at some distance from the latter. Owing to this dissipation the period of vibration of an air-condenser can not be accurately determined, and I have already drawn attention to this important fact.

These waves are propagated at right angles from the charged surfaces when their charges are alternated, and dissipation occurs, even if the surfaces are covered with thick and excellent insulation. Assuming that the "charge" imparted to a molecule or atom either by direct contact or inductively is proportionate to the electric density of the surface, the dissipation should be proportionate to the square of the density and to the number of waves per second. The above assumption, it should be stated, does not agree with some observations from which it appears that an atom can not take but a certain maximum charge; hence, the charge imparted may be practically independent of the density of the surface, but this is immaterial for the present consideration. This and other points will be decided when accurate quantitative determinations, which are as yet wanting, shall be made. At present it appears certain from experiments with high-frequency currents, that this dissipation of energy from a wire, for instance, is not very far from being proportionate to the frequency of the alter-

nations, and increases very rapidly when the diameter of the wire is made exceedingly small. On the latter point the recently published results of Prof. Ayrton and H. Kilgour on "The Thermal Emissivity of Thin Wires in Air" throw a curious light. Exceedingly thin wires are capable of dissipating a comparatively very great amount of energy by the agitation of the surrounding air, when they are connected to a source of rapidly alternating potential. So in the experiment cited, a thin hot wire is found to be capable of emitting an extraordinarily great amount of heat, especially at elevated temperatures. In the case of a hot wire it must of course be assumed that the increased emissivity is due to the more rapid convection and not, to any appreciable degree, to an increased radiation. Were the latter demonstrated, it would show that a wire, made hot by the application of heat in ordinary ways, behaves in some respects like one, the charge of which is rapidly alternated, the dissipation of energy per unit of surface kept at a certain temperature depending on the curvature of the surface. I do not recall any record of experiments intended to demonstrate this, yet this effect, though probably very small, should certainly be looked for.

A number of observations showing the peculiarity of very thin wires were made in the course of my experiments. I noted, for instance, that in the well-known Crookes instrument the mica vanes are repelled with comparatively greater force when the incandescent platinum wire is exceedingly thin. This observation enabled me to produce the spin of such vanes mounted in a vacuum tube when the latter was placed in an alternating electrostatic field. This however does not prove anything in regard to radiation, as in a highly exhausted vessel the phenomena are principally due to molecular bombardment or convection.

When I first undertook to produce the incandescence of a wire enclosed in a bulb, by connecting it to only one of the terminals of a high tension transformer, I could not succeed for a long time. On one occasion I had mounted in a bulb a thin platinum wire, but my apparatus was not adequate to produce the incandescence. I made other bulbs, reducing the length of the wire to a small fraction; still I did not succeed. It then occurred to me that it would be desirable to have the surface of the wire as large as possible, yet the bulk small, and I provided a bulb with an exceedingly thin wire of a bulk about equal to that of the short but much thicker wire. On turning the current on the bulb the wire was instantly fused. A series of subsequent experiments showed, that when the diameter of the wire was exceedingly small, considerably more energy would be dissipated per unit surface at all degrees of exhaustion than was to be expected, even on the assumption that the energy given off was in proportion to the square of the electric density. There is likewise evidence which, though not possessing the certainty of an accurate quantitative determination, is nevertheless reliable because it is the result of a great many observations, namely, that with the increase of the density the dissipation is more rapid for thin than for thick wires.

The effects noted in exhausted vessels with high-frequency currents are merely diminished in degree when the air is at ordinary pressure, but heating and dissipation occurs, as I have demonstrated, under the ordinary atmospheric conditions. Two very thin wires attached to the

terminals of a high-frequency coil are capable of giving off an appreciable amount of energy. When the density is very great, the temperature of the wires may be perceptibly raised, and in such case probably the greater portion of the energy which is dissipated *owing to the presence of a discontinuous medium* is transformed into heat at the surface or in close proximity to the wires. Such heating could not occur in a medium possessing either of the two qualities, namely, perfect incompressibility or perfect elasticity. In fluid insulators, such as oils, though they are far from being perfectly incompressible or elastic to electric displacement, the heating is much smaller because of the continuity of the fluid.

When the electric density of the wire surfaces is small, there is no appreciable local heating, nevertheless energy is dissipated in air by waves, which differ from ordinary sound-waves only because the air is electrified. These waves are especially conspicuous when the discharges of a powerful battery are directed through a short and thick metal bar, the number of discharges per second being very small. The experimenter may feel the impact of the air at distances of six feet or more from the bar, especially if he takes the precaution to sprinkle the face or hands with ether. These waves cannot be entirely stopped by the interposition of an insulated metal plate.

Most of the striking phenomena of mechanical displacement, sound, heat and light which have been observed, imply the presence of a medium of a gaseous structure, that is, one consisting of independent carriers capable of free motion.

When a glass plate is placed near a condenser the charge of which is alternated, the plate emits a sound. This sound is due to the rythmical impact of the air against the plate. I have also found that the ringing of a condenser, first noted by Sir William Thomson, is due to the presence of the air between or near the charged surfaces.

When a disruptive discharge coil is immersed in oil contained in a tank, it is observed that the surface of the oil is agitated. This may be thought to be due to the displacements produced in the oil by the changing stresses, but such is not the case. It is the air above the oil which is agitated and causes the motion of the latter; the oil itself would remain at rest. The displacements produced in it by changing electrostatic stresses are insignificant; to such stresses it may be said to be compressible to but a very small degree. The action of the air is shown in a curious manner for, if a pointed metal bar is taken in the hand and held with the point close to the oil, a hole two inches deep is formed in the oil by the molecules of the air, which are violently projected from the point.

The preceding statements may have a general bearing upon investigations in which currents of high frequency and potential are made use of, but they also have a more direct bearing upon the experiments of Prof. Bjerknæs which are here considered, namely, the "skin effect," is increased by the action of the air. Imagine a wire immersed in a medium, the conductivity of which would be some function of the frequency and potential difference but such, that the conductivity increases when either or both of these elements are increased. In such a medium, the higher the frequency and potential difference, the greater will be the current which will find its way through the surrounding medium, and the smaller the part which will pass through the central portion of the wire. In the case of a wire immersed in air and traversed by a high-frequency current, the facility with which the energy is dissipated may be considered as the equivalent of the conductivity; and the analogy would be quite complete, were it not that besides the air another medium is present, the total dissipation being merely modified by the presence of the air to an extent as yet not ascertained. Nevertheless, I have sufficient evidence to draw the conclusion, that the results obtained by Prof. Bjerknæs are affected by the presence of air in the following manner: 1. The dissipation of energy

is more rapid when the resonator is immersed in air than it would be in a practically continuous medium, for instance, oil. 2. The dissipation owing to the presence of air renders the difference between magnetic and non-magnetic metals more striking. The first conclusion follows directly from the preceding remarks; the second follows from the two facts that the resonator receives always the same amount of energy, independent of the nature of the metal, and that the magnetism of the metal increases the impedance of the circuit. A resonator of magnetic metal behaves virtually as though its circuit were longer. There is a greater potential difference set up per unit of length, although this may not show itself in the deflection of the electrometer owing to the lateral dissipation. The effect of the increased impedance is strikingly illustrated in the two experiments of Prof. Bjerknæs when copper is deposited upon an iron wire, and next iron upon a copper wire. Considerable thickness of copper deposit was required in the former experiment, but very little thickness of iron in the latter, as should be expected.

Taking the above views, I believe, that in the experiments of Prof. Bjerknæs which lead him to undoubtedly correct conclusions, the air is a factor fully as important, if not more so, than the resistance of the metals.

STATISTICS OF ELECTRICAL MANUFACTURE IN GERMANY.

THE following statistics with regard to the value of electrical goods manufactured in Germany, and relating to the years 1890 and 1891, were recently given by the *Elektrotechnische Zeitschrift* on the authority of Herr Fr. Vogel. Telegraphic apparatus to the value of \$280,000 was made; telephones, over \$400,000; railway signalling apparatus, nearly \$400,000; total, with electric bells, etc., about \$2,000,000. During 1890-1891: 3,500 continuous current dynamos, alternators and transformers were built each year to the value of \$1,600,000. In 1886 a large German firm built 350 machines, having a total output of 2,500,000 watts. Last year the same firm turned out 760 machines, the total output of which was 10,000,000 watts, the average size of machine being, therefore, about $9\frac{1}{2}$ h. p. and $17\frac{1}{2}$ h. p. respectively. Accumulators are being manufactured and sold in Germany to the amount of \$1,120,000 per annum. About 17,000 arc lamps are made every year, their value being about \$500,000. The arc-light carbon product amounts to nearly \$400,000 per annum, and the incandescent lamp product to \$640,000. The value of the total annual electrical output of all sorts is placed at \$6,600,000 or \$6,700,000. The number of persons employed in electrical factories is about 15,000.

MAXIMUM SPEED ON ELECTRIC RAILWAYS.

In a contribution to the *Elektrotechnische Zeitschrift*, Mr. J. Kraemer comments on the current statements regarding high speed on electric railways, and presents an array of formulas for calculating the effect of air pressure, dead weight and other factors on the maximum possible speed. He thinks that 500 kilometres per hour is the highest speed yet attained by experiments made on a laboratory scale; the dead weight of the cars, engines, trucks and the fuel used reduces this to about 150 kilometres. The limited rate of reciprocation of the steam engine part of the locomotive suggests larger driving wheels, but the size of these is limited by the radius of the curves. These factors, together with the allowances for air resistance, slipping on the rails and the average grades still further reduce this speed, so that electric railways must be able to alter the conditions materially in order to attain a speed of even 200 kilometres per hour, corresponding to about 125 miles per hour—quite a promising figure.

MISCELLANEOUS.

THE PHYSIOLOGICAL AND OTHER EFFECTS OF HIGH FREQUENCY CURRENTS.

BY



IN THE ELECTRICAL ENGINEER, of January 25, 1893, I note an article by Mr. A. C. Swinton, referring to my experiments with high frequency currents. Mr. Swinton uses in these experiments the method of converting described by me in my paper before the American Institute of Electrical Engineers, in May, 1891, and published in THE ELECTRICAL ENGINEER of July 8, 1891, which has since been employed by a number of experimenters; but it has somewhat surprised me to observe that he makes use of an ordinary vibrating contact-breaker, whereas he could have employed the much simpler method of converting continuous currents into alternating currents of any frequency which was shown by me two years ago. This method does not involve the employment of any moving parts, and allows the experimenter to vary the frequency at will by simple adjustments. I had thought that most electricians were at present familiar with this mode of conversion which possesses many beautiful features.

The effects observed by Mr. Swinton are not new to me and they might have been anticipated by those who have carefully read what I have written on the subject. But I cannot agree with some of the views expressed by him.

First of all, in regard to the physiological effects. I have made a clear statement at the beginning of my published studies, and my continued experience with these currents has only further strengthened me in the opinion then expressed. I stated in my paper, before mentioned, that it is an undeniable fact that currents of very high frequency are less injurious than the low frequency currents, but I have also taken care to prevent the idea from gaining ground that these currents are absolutely harmless, as will be evident from the following quotation: "If received directly from a machine or from a secondary of low resistance, they (high frequency currents) produce more or less powerful effects, and may cause serious injury, especially when used in conjunction with condensers." This refers to currents of ordinary potential differences such as are used in general commercial practice.

As regards the currents of very high potential differences, which were employed in my experiments, I have never considered the current's strength, but the energy which the human body was capable of receiving without injury, and I have expressed this quite clearly on more than one occasion. For instance, I stated that "the higher the frequency the greater the amount of electrical energy which may be passed through the body without serious discomfort." And on another occasion when a high tension coil was short-circuited though the body of the experimenter I stated that the immunity was due to the fact that less energy was available externally to the coil when the experimenter's body joined the terminals. This is practically what Mr. Swinton expresses in another way; namely, by saying that with "high frequency currents it is possible to obtain effects with exceedingly small currents," etc.

In regard to the experiments with lamp filaments, I have, I believe, expressed myself with equal clearness. I have pointed out some phenomena of impedance which at that time (1891) were considered very striking, and I have also pointed out the great importance of the rarefied gas surrounding the filament when we have to deal with currents of such high frequency. The heating of the filament by a comparatively small current is not, as Mr. Swinton thinks, due to its impedance or increased ohmic resistance, but principally to the presence of rarefied gas in the bulb. Ample evidence of the truth of this can be obtained in very many experiments, and to cite them would be merely lengthening this communication unduly.

Likewise, observations made when the experimenter's body was included in the path of the discharge, are, in my opinion, not impedance, but capacity, phenomena. The spark between the hands is the shorter, the larger the surface of the body, and no spark whatever would be obtained if the surface of the body were sufficiently large.

I would here point out that one is apt to fall into the error of supposing that the spark which is produced between two points on a conductor, not very distant from each other, is due to the impedance of the conductor. This is certainly the case when the current is of considerable strength, as for instance when, like in the Faraday experiment or some of Dr. Lodge's, a heavily-charged

battery of Leyden jars is discharged through a bent wire. But, when there is a vibration along a wire which is constantly maintained, and the current is inappreciable whereas the potential at the coil terminal is exceedingly high, then lateral dissipation comes into play prominently. There is then, owing to this dissipation, a rapid fall of potential along the wire and high potential differences may exist between points only a short distance apart. This is of course not to be confounded with those differences of potential observed between points when there are fixed waves with ventral and nodal points maintained on a conductor. The lateral dissipation, and not the skin effect, is, I think, the reason why so great an amount of energy may be passed into the body of a person without causing discomfort.

It always affords me great pleasure to note, that something which I have suggested is being employed for some instructive or practical purpose; but I may be pardoned for mentioning that other observations made by Mr. Swinton, and by other experimenters, have recently been brought forward as novel, and arrangements of apparatus which I have suggested have been used repeatedly by some who apparently are in complete ignorance of what I have done in this direction.

ELECTRICAL RECORDING METERS.—II.

BY CARYL D. HASKINS.

There is another device, or perhaps I had better say there might be another device for accomplishing the object of this last meter in a somewhat similar manner. The actinometer is probably familiar to all who have indulged in amateur photography; it consists of a piece of glass covered with small cubes, each cube of a more intense ruby red than the one beyond it, merging, in fact, from an almost clear glass to an almost perfectly non-actinic medium. Now, it suggests itself to a certain electrician that if a number of these squares were arranged in a piece of glass, one above the other, and a lamp whose light should vary more or less directly with the potential on the lines, be placed before this glass or actinometer, a sensitive film being rotated behind the actinometer at a constant speed, that the varying light of the lamp would draw a curved line, or rather a curved block of light and shade on the paper, which would be measured by a planimeter to get the average voltage, or could be taken at points, to see what the voltage was at certain times; in fact, a recording voltmeter. This device seemed very nice indeed. It had only one fault—it would not work. I might say that the device is my own.

There is almost an endless variety of clock meters. They are not all electricity meters by any means; some are recording voltmeters, others recording ammeters, and others have still different purposes. The familiar recording steam gauge is only a modification of this instrument. A paper is almost invariably rotated over a drum, sometimes being fixed to the drum, and sometimes being drawn from one drum to another, the paper moving at uniform speed, and generally being divided into hours or other fractions of time by abscissæ lines.

This clock mechanism can be combined with any indicating device; it is only necessary to supply the connection which shall cause the indicator to mark the paper, and draw a crooked line. First attempts of this kind are generally made with an ordinary solenoid, or sometimes with a simple coil and iron core rising and falling with the current. Whatever the character of the indicator or method of communication between the indicator and paper, it remained necessary to keep the friction of contact low.

First attempts were made with a pencil, bearing directly upon the paper, but the friction introduced by this device was fatal to accuracy. A glass pen has been substituted for the pencil with better results, but even this caused too much friction. The photographic method of line drawing is one of the best systems yet introduced, and is probably more familiar to the majority of us than other methods, because it forms a component part of the Walker meter which has attracted attention at various times.

One of the best methods of accomplishing the registration, perhaps, when all things are considered, the very best, is to attach to the pointer of the indicator, a steel point or needle with an iron armature mounted in the form of a spring, or in some similar manner. By placing an electromagnet behind the paper to be marked, and sending through this magnet an electrical impulse at fixed periods of say, one, two or five minutes, the pointer is drawn sharply down to the paper, puncturing it, and is immediately released by the cessation of energizing current in the electromagnet. Thus, the paper when removed, will have a continuous marking of punctures tantamount to a curved line. This device presents practically no friction, and is more or less simple and easy to carry out. The make-and-break necessary for the electromagnet is easily actuated by the clock movements. But we may say of these forms, as well as of the forms of clock meter which are to follow, that there is one serious objection to them all—they have to be wound up, which is certainly a fault. We may modify this statement by saying that many of these devices have an electrical attachment which makes them self-winding,

The Detroit Free Press

Feb. 16, 1896, p. 16.

FROM NI(C)OLA TESLA - HE WRITES ABOUT HIS EXPERIMENTS IN ELECTRICAL HEALING.

Some weeks ago this journal published an interesting article concerning electrical oscillations as observed by the eminent scientist, Ni(c)ola Tesla. So much interest was shown in the subject that Mr. Tesla was appealed to directly and in response to that appeal he sends to *The Detroit Free Press* this open letter:

Nos. 46 & 48 E. Houston Street
New York, February 10, 1896

During the past few weeks I have received so many letters concerning the same subject that it was entirely beyond my power to answer all of them individually. In view of this I hope that I shall be excused for the delay, which I must regret, in acknowledging the receipt, and also for addressing this general communication in answer to all inquiries.

The many pressing demands which have been made upon me in consequence of exaggerated statements of the journals have painfully impressed me with the fact that there are a great many sufferers, and furthermore that nothing finds a more powerful echo than a promise held out to improve the condition of the unfortunate ones.

The members of the medical fraternity are naturally more deeply interested in the task of relieving the suffering from their pain, and, as might be expected, a great many communications have been addressed to me by physicians. To these chiefly this brief statement of the actual facts is addressed.

Some journals have confounded the physiological effects of electrical oscillations with those of mechanical vibrations, this being probably due to the circumstance that a few years ago I brought to the attention of the scientific men some novel methods and apparatus for the production of electrical oscillations which, I learn, are now largely used in some modification or other in electro-therapeutic treatment and otherwise. To dispel this erroneous idea I wish to state that the effects of purely mechanical vibrations which I have more recently observed, have nothing to do with the former.

Mechanical vibrations have often been employed locally with pronounced results in the treatment of diseases, but it seems that the effects I refer to have either not been noted at all, or if so, only to a small degree, evidently because of the insufficiency of the means which have eventually been employed in the investigations.

While experimenting with a novel contrivance, constituting in its simplest form a vibrating mechanical system, in which from the nature of the construction the applied force is always in resonance with the natural period, I frequently exposed my body to continued mechanical vibrations. As the elastic force can be made as large as desired, and the applied force used be very small, great weights, half a dozen persons, for instance, may be vibrated with great rapidity by a comparatively small apparatus.

I observed that such intense mechanical vibrations produce remarkable physiological effects. They affect powerfully the condition of the stomach, undoubtedly promoting the process of digestion and relieving the feeling of distress, often experienced in consequence of the imperfect function of the organs concerned in the process. They have a strong influence upon the liver, causing it to discharge

freely, similarly to an application of a cathartic. They also seem to affect the glandular system, notably in the limbs; also the kidneys and bladder, and more or less influence the whole body. When applied for a longer period they produce a feeling of immense fatigue, so that a profound sleep is induced.

The excessive tiring of the body is generally accompanied by nervous relaxation, but there seems to be besides a specific action on the nerves.

These observations, though incomplete, are, in my own limited judgment, nevertheless positive and unmistakable, and in view of this and of the importance of further investigation of the subject by competent men I prepared about a year ago a machine with suitable adjustments for varying the frequency and amplitude of the vibrations, intending to give it to some medical faculty for investigation. This machine, together with other apparatus, was unfortunately destroyed by fire a year ago, but will be reconstructed as soon as possible.

In making the above statements I wish to disconnect myself with the extraordinary opinions expressed in some journals which I have never authorized and which, though they may have been made with good intent, cannot fail to be hurtful by giving rise to visionary expectations.

Yours very truly,

N. Tesla

Electrical Review - N. Y.
March 18, 1896, p. 147

TESLA'S LATEST RESULTS

HE NOW PRODUCES RADIOGRAPHS AT A DISTANCE OF MORE THAN FORTY FEET.

To The Editor of *Electrical Review*:

Permit me to say that I was slightly disappointed to note in your issue of Mar. 11 the prominence you have deemed to accord to my youth and talent, while the ribs and other particulars of Fig. 1, which, with reference to the print accompanying my communication, I described as clearly visible, were kept modestly in the background. I also regretted to observe an error in one of the captions, the more so, as I must ascribe it to my own text. I namely stated on page 135, third column, seventh line: "A similar impression was obtained through the body of the experimenter, etc., through a distance of four feet." The impression here referred to was a similar one to that shown in Fig. 2, whereas the shadow in Fig. 1 was taken through a distance of 18 inches. I state this merely for the sake of correctness of my communication, but, as far as the general truth of the fact of taking such a shadow at the distance given is concerned, your caption might as well stand, for I am producing strong shadows at distances of 40 *feet*. I repeat, 40 feet and even more. Nor is this all. So strong are the actions on the film that provisions must be made to guard the plates in my photographic department, located on the floor above, a distance of fully 60 feet, from being spoiled by long exposure to the stray rays. Though during my investigations I have performed many experiments which seemed extraordinary, I am deeply astonished observing these unexpected manifestations, and still more so, as even now I see before me the possibility, not to say certitude, of augmenting the effects with my apparatus at least tenfold! What may we then expect? We have to deal here, evidently, with a radiation of astonishing power, and the inquiry into its nature becomes more and more interesting and important.

Here is an unlooked-for result of an action which, though wonderful in itself, seemed feeble and entirely incapable of such expansion, and affords a good example of the fruitfulness of original discovery. These effects upon the sensitive plate at so great a distance I attribute to the employment of a bulb with a single terminal, which permits the use of practically any desired potential and the attainment of extraordinary speeds of the projected particles. With such a bulb it is also evident that the action upon a fluorescent screen is proportionately greater than when the usual kind of tube is employed, and I have already observed enough to feel sure that great developments are to be looked for in this direction. I consider Roentgen's discovery, of enabling us to see, by the use of a fluorescent screen, through an opaque substance, even a more beautiful one than the recording upon the plate.

Since my previous communication to you I have made considerable progress, and can presently announce one more result of importance. I have lately obtained shadows by *reflected rays only*, thus demonstrating beyond doubt that the Roentgen rays possess this property. One of the experiments may be cited here. A thick copper tube, about a foot long, was taken and one of its ends tightly closed by the plate-holder containing a sensitive plate, protected by a fiber cover as usual. Near the open end of the copper tube was placed a thick plate of glass at an angle of 45 degrees to the axis of the tube. A single-terminal bulb was then suspended above the glass plate at a distance of about eight inches, so that the bundle of rays fell upon the latter at an angle of 45 degrees, and the supposedly reflected rays passed along the axis of the copper tube. An exposure of 45 minutes gave a clear and sharp shadow of a metallic object. This shadow was produced by the reflected rays, as the direct action was absolutely excluded, it having been demonstrated that even under the severest tests with much stronger actions no impression whatever could be produced upon the film through a thickness of copper equal to that of the tube. Concluding from the intensity of the action by comparison with an equivalent effect due to the direct rays, I find that approximately two per cent of the latter were reflected from the glass plate in this experiment. I hope to be able to report shortly and more fully on this and other subjects.

In my attempts to contribute my humble share to the knowledge of the Roentgen phenomena, I am finding more and more evidence in support of the theory of moving material particles. It is not my intention, however, to advance at present any view as to the bearing of such a fact upon the present theory of light, but I merely seek to establish the fact of the existence of such material streams in so far as these isolated effects are concerned. I have already a great many indications of a bombardment occurring outside of the bulb, and I am arranging some crucial tests which, I hope, will be successful. The calculated velocities fully account for actions at distances of as much as 100 feet from the bulb, and that the projection through the glass takes place seems evident from the process of exhaustion, which I have described in my previous communication. An experiment which is illustrative in this respect, and which I intended to mention, is the following; If we attach a fairly exhausted bulb containing an electrode to the terminal of a disruptive coil, we observe small streamers breaking through the side of the glass. Usually such a streamer will break through the seal and crack the bulb, whereupon the vacuum is impaired; but, if the seal is placed above the terminal, or if some other provision is made to prevent the streamer from passing through the glass at that point, it often occurs that the stream breaks out through the side of the bulb, producing a fine hole. Now, the extraordinary thing is that, in spite of the connection to the outer atmosphere, the air can not rush into the bulb as long as the hole is very small. The glass at the place where the rupture has occurred may grow very hot - to such a degree as to soften; but it will not collapse, but rather bulge out, showing that a pressure from the inside greater than that of the atmosphere exists. On frequent occasions I have observed that the glass bulges out and the hole, through which the streamer rushes out, becomes so large as to be

perfectly discernible to the eye. As the matter is expelled from the bulb the rarefaction increases and the streamer becomes less and less intense, whereupon the glass closes again, hermetically sealing the opening. The process of rarefaction, nevertheless, continues, streamers being still visible on the heated place until the highest degree of exhaustion is reached, whereupon they may disappear. Here, then, we have a positive evidence that matter is being expelled through the walls of the glass.

When working with highly strained bulbs I frequently experience a sudden, and sometimes even painful, shock in the eye. Such shocks may occur so often that the eye gets inflamed, and one can not be considered over-cautious if he abstains from watching the bulb too closely. I see in these shocks a further evidence of larger particles being thrown off from the bulb.

Nikola Tesla.

New York, March 14.

Mining and Scientific Press

May 9, 1896, p. 378.

Electrical Progress.

On Apparatus for Cathography.

By NIKOLA TESLA.

In order to produce the most intense effects, we have first to consider that, whatever their nature, they depend necessarily on the intensity of the cathode streams. Then, again, being dependent on the magnitude of the potential, it follows that the highest attainable electrical pressure is desirable.

To obtain high potentials we may avail ourselves of an ordinary induction coil, or of a static machine, or preferably of a disruptive discharge coil. If we put two electrodes in a bulb, or use one inside and another outside electrode, we limit the potential, for the presence not only of the anode, but of any conducting object, has the effect of reducing the practicable potential on the cathode. Thus, to secure the result aimed at, one is driven to the acceptance of a single electrode bulb, the other terminal being as far remote as possible.

Having selected the induction apparatus and type of bulb, the next important consideration is the vacuum. On this subject I am able to make known a fact with which I have long been acquainted, and of which I have taken advantage in the production of vacuum jackets and incandescent bulbs, and which I subsequently found to be of the utmost importance, not to say essential, for the production of intense Roentgen shadows. I refer to a method of rarefaction by electrical means to any degree desirable, far beyond that obtainable by mechanical appliances.

Though this result can be reached by the use of a static machine, as well as of an ordinary induction coil giving a sufficiently high potential, I have found that by far the most suitable apparatus, and one which secures the quickest action, is a disruptive coil. It

is best to proceed in this way: The bulb is first exhausted by means of an ordinary vacuum pump to a rather high degree, though my experiences have shown that this is not absolutely necessary, as I have also found it possible to rarefy, beginning from low pressure. After being taken down from the pump, the bulb is attached to the terminal of the disruptive coil, preferably of high frequency of vibration, and usually the following phenomena are noted: First, there is a milky light spreading through the bulb, or possibly for a moment the glass becomes phosphorescent, if the bulb has been exhausted to a high degree. At any rate, the phosphorescence generally subsides quickly and the white light settles around the electrode, whereupon a dark space forms at some distance from the latter. Shortly afterwards the light assumes a reddish color and the terminal grows very hot. This heating, however, is observed only with powerful apparatus. It is well to watch the bulb carefully and regulate the potential at this stage, as the electrode might be quickly consumed.

After some time the reddish light subsides, the streams becoming again white, whereupon they get weaker and weaker, wavering around the electrode until they finally disappear. Meanwhile, the phosphorescence of the glass grows more and more intense, and the spot where the stream strikes the wall becomes very hot, while the phosphorescence around the electrode ceases and the latter cools down to such an extent that the glass near it may be actually ice-cold to the touch. The gas in the bulb has then reached the required degree of rarefaction. The process may be hastened by repeated heating and cooling and by the employment of a small electrode.

I may state here that the experimenter need not be deterred from using a glass bulb, as I believe the opacity of glass, as well as the transparency of aluminium, are somewhat exaggerated, inasmuch as I have found that a very thin aluminium sheet throws a marked shadow, while, on the other hand, I have obtained impressions through a thick glass plate.

The above method is not only valu-

able as a means of obtaining the high vacua desired, but it is still more important, because the phenomena observed throw a light on the results obtained by Lenard and Roentgen.

Though the phenomenon of rarefaction under above conditions admits of different interpretations, the chief interest centers on one of them, to which I adhere—that is, on the actual expulsion of the particles through the walls of the bulb. I have lately observed that the latter commences to act properly upon the sensitive plate only from the point when the exhaustion begins to be noticeable, and the effects produced are the strongest when the process of exhaustion is most rapid, even though the phosphorescence might not appear particularly bright. Evidently, then, the two effects are closely connected, and I am getting more and more convinced that we have to deal with a stream of material particles, which strike the sensitive plate with great velocities. Taking as a basis the estimate of Lord Kelvin on the speed of projected particles in a Crookes' bulb, we arrive easily by the employment of very high potentials to speeds of as much as a hundred kilometers a second.

It may not be known that even an ordinary streamer, breaking out suddenly and under great pressure from the terminal of a disruptive coil, passes through a thick glass plate as though the latter were not present. Unquestionably, with such coils pressures are practicable which will project the particles in straight lines even under atmospheric pressure. I have obtained distinct impressions in free air, not by streamers, as some experimenters have done, using static machines or induction coils, but by actual projection, the formation of streamers being absolutely prevented by careful static screening.

A valuable evidence of the nature of the radiations and progress in the direction of obtaining strong impressions on the plate might be arrived at by perfecting plates especially sensitive to mechanical shock or impact. There are chemicals suitable for this, and the development in this direction may lead to the abandonment of the

tion coils, but by actual projection, the formation of streamers being absolutely prevented by careful static screening.

A valuable evidence of the nature of the radiations and progress in the direction of obtaining strong impressions on the plate might be arrived at by perfecting plates especially sensitive to mechanical shock or impact. There are chemicals suitable for this, and the development in this direction may lead to the abandonment of the present plate. Furthermore, if we have to deal with streams of material particles, it seems not impossible to project upon the plate a suitable substance to insure the best chemical action.

By exposing the head to a powerful radiation strange effects have been noted. For instance, I find that there is a tendency to sleep and the time seems to pass away quickly. There is a general soothing effect, and I have felt a sensation of warmth in the upper part of the head. An assistant independently confirmed the tendency to sleep and a quick lapse of time. Should these remarkable effects be verified by men with keener sense of observation, I shall still more firmly believe in the existence of material streams penetrating the skull. Thus it may be possible to project a suitable chemical into any part of the body.

Since my above-mentioned discoveries I have made considerable progress, and can presently announce one more result of importance. I have lately obtained shadows by reflected rays only, thus demonstrating beyond doubt that the Roentgen rays possess this property. One of the experiments may be cited here. A thick copper tube, about a foot long, was taken and one of its ends tightly closed by the plate-holder containing a sensitive plate, protected by a fiber cover as usual. Near the open end of the copper tube was placed a thick plate glass at an angle of 45° to the axis of the tube. A single terminal bulb was then suspended above the glass plate at a distance of about eight inches, so that the bundle of rays fell upon the latter at an angle of 45° , and supposedly reflected rays passed along the axis of the copper tube. An exposure of forty-five minutes gave a clear and sharp shadow of a metallic object. This shadow was produced by the reflected rays, as the direct action was absolutely excluded, it having been demonstrated that, even under the severest tests with much stronger actions, no impression whatever could be produced upon the film through a thickness of copper equal to that of the tube. Concluding from the intensity of the action by comparison with an equivalent effect due to the direct rays, I find that approximately two per cent of the latter were reflected from the glass plate in this experiment.

The Electrical Engineer - N. Y.
December 23, 1896, p. 655

MR. TESLA ON THERMO ELECTRICITY.

In a letter to the editor of the Buffalo Enquirer, Mr. Nikola Tesla replies as follows in regard to an inquiry on the subject of the future of electricity:

"The transmission of power has interested me not only as a technical problem, but far more in its bearing upon the welfare of mankind. In this sense I have expressed myself in a lecture, delivered some time ago.

"Since electrical transmission of energy is a process much more economical than any other we know of, it necessarily must play an important part in the future, no matter how the primary energy is derived from the sun. Of all the ways the utilization of a waterfall seems to be the simplest and least wasteful. Even if we could, by combining carbon in a battery, convert the work of the chemical combination into electrical energy with very high economy, such mode of obtaining power would, in my opinion, be no more than a mere makeshift, bound to be replaced sooner or later by a more perfect method, which implies no consumption of any material whatever."

Cassiers Magazine - London
March, 1897, pp. 378-386.

THE AGE OF ELECTRICITY.

by Nikola Tesla

The commemoration of the recent introduction into the city of Buffalo of electric power from Niagara Falls was made the occasion of a banquet, held at the Ellicott Club, at Buffalo on January 12, 1897, the hosts being the Niagara Falls Power and Conduit Company, and the distinguished guests the men, principally, to whose business and engineering talents the world owes the remarkable Niagara undertaking so recently brought to successful completion. Probably none among these has been more honoured than Mr. Nikola Tesla, whose electrical researches and practical accomplishments have been the talk of the world, and whose polyphase alternating current system was the one eventually adopted in the work at Niagara Falls. After the banquet, in responding to the toast, "Electricity," Mr. Tesla spoke at length of the various sciences, with special reference, naturally to electricity, and from his remarks the appended extracts have been made, picturing in a graphic and striking manner the dependence upon power of the development and wealth of cities, the success of nations, the progress of the whole human race, in fact, as he himself put it. - THE EDITOR.

For more than half a century the steam engine has served the innumerable wants of man. The work it was called to perform was of such variety, and the conditions in each case were so different that, of necessity, a great many types of engines resulted. In the vast majority of cases the problem put before the engineer was not, as it should have been, the broad one of converting the greatest possible amount of heat energy into mechanical power, but it was rather the specific problem of obtaining the mechanical power in such form as to be best suitable for general use. As the reciprocating motion of the piston was not convenient for practical purposes, except in very few instances, the piston was connected to a crank, and thus rotating motion was obtained, which was more suitable and preferable, though it involved numerous disadvantages incident to the crude and wasteful means employed. But until quite recently there were at the disposal of the engineer, for

the transformation and transmission of the motion of the piston, no better means than rigid mechanical connections.

The past few years have brought forcibly to the attention of the builder the electric motor, with its ideal features. Here was a mode of transmitting mechanical motion, simpler by far, and also much more economical. Had this mode been perfected earlier, there can be no doubt that the majority of the many types of engines would not exist, for just as soon as an engine was coupled with an electric generator a type was produced capable of almost universal use. From this moment on there was no necessity to endeavor to perfect engines of special designs capable of doing special kinds of work. The engineer's task became now to concentrate all his efforts upon one type, to perfect one kind of engine - the best, the universal, the engine of the immediate future; namely, the one which is best suitable for the generation of electricity.

The first efforts in this direction gave a strong impetus to the development of the reciprocating high-speed engine, and also to the turbine, which latter was a type of engine of very limited practical usefulness, but became, to a certain extent, valuable in connection with the electric generator and motor. Still, even the former engine, though improved in many particulars, is not radically changed, and even now has the same objectionable features and limitations. To do away with these as much as possible, a new type of engine is being perfected in which more favourable conditions for economy are maintained, which expands the working fluid with utmost rapidity and loses little heat on the walls of the engine stripped of all usual regulating mechanism - packings, oilers and other appendages - and forming part of an electric generator; and in this type, I may say, I have implicit faith.

The gas or explosive engine has been likewise profoundly affected by the commercial introduction of electric light and power, particularly in quite recent years. The engineer is turning his energies more and more in this direction, being attracted by the prospect of obtaining a higher thermodynamic efficiency. Much larger engines are now being built, the construction is constantly improved, and a novel type of engine, best suitable for the generation of electricity, is being rapidly evolved.

There are many other lines of manufacture and industry in which the influence of electrical development has been even more powerfully felt, - for instance, the manufacture of a great variety of articles of metal, and especially of chemical products. The welding of metals by electricity, though involving a wasteful process, has, nevertheless, been accepted as a legitimate art, while the manufacture of metal sheet, seamless tubes and the like affords promise of much improvement.

We are coming gradually, but surely, to the fusion of bodies and reduction of all kinds of ores - even of iron ores - by the use of electricity, and in each of these departments great realisations are probable. Again, the economical conversion of ordinary currents of supply into high-frequency currents opens up new possibilities, such as the combination of the atmospheric nitrogen and the production of its compounds; for instance, ammonia and nitric acid, and their salts, by novel processes.

To enumerate the many advances recorded is a subject for the reviewer, but I cannot pass without mentioning the beautiful discoveries of Lenard and Roentgen, particularly the latter, which have found such a powerful response throughout the scientific world that they have made us forget, for a time, the great achievement of Linde in Germany, who has effected the liquefaction of air on an industrial scale by a process of continuous cooling; the discovery of argon by Lord Raleigh and Professor Ramsay, and the splendid pioneer work of Professor Dewar in the field of low temperature research. The fact that the United States have contributed a very

liberal share to this prodigious progress must afford to all of us great satisfaction.

While honouring the workers in other countries and all those who, by profession or inclination, are devoting themselves to strictly scientific pursuits, Americans have particular reasons to mention with gratitude the names of those who so much contributed to this marvelous development of electrical industry in the United States. Bell, who, by his admirable invention enabling us to transmit speech to great distances, has profoundly affected our commercial and social relations, and even our very mode of life; Edison, who, had he not done anything else beyond his early work in incandescent lighting, would have proved himself one of the greatest benefactors of the age; Westinghouse, the founder of the commercial alternating system; Brush, the great pioneer of arc lighting; Thomson, who gave us the first practical welding machine, and who, with keen sense, contributed very materially to the development of a number of scientific and industrial branches; Weston, who once led the world in dynamo design, and now leads in the construction of electric instruments; Sprague, who, with rare energy, mastered the problem and insured the success of practical electrical railroading; Acheson, Hall, Willson and others, who are creating new and revolutionising industries here under our very eyes at Niagara.

Nor is the work of these gifted men nearly finished at this hour. Much more is still to come, for fortunately, most of them are still full of enthusiasm and vigour. All of these men and many more are untiringly at work investigating new regions and opening up unsuspected and promising fields. Weekly, if not daily, we learn through the journals of a new advance into some unexplored region, where at every step success beckons friendly, and leads the toiler on to hard and harder tasks.

But among all these many departments of research, these many branches of industry, new and old, which are being rapidly expanded, there is one dominating all others in importance - one which is of the greatest significance for the comfort and welfare, not to say for the existence, of mankind, and that is the electrical transmission of power. And in this most important of all fields long afterwards, when time will have placed the events in their proper perspective, and assigned men to their deserved places, the great event we are commemorating to-day will stand out as designating a new and glorious epoch in the history of humanity - an epoch grander than that marked by the advent of the steam engine.

We have many a monument of past ages; we have the palaces and pyramids; the temples of the Greek and the cathedrals of Christendom. In them is exemplified the power of men, the greatness of nations, the love of art and religious devotion. But that monument at Niagara has something of its own, more in accord with our present thoughts and tendencies. It is a monument worthy of our scientific age, a true monument of enlightenment and of peace. It signifies the subjugation of natural forces to the service of man, the discontinuance of barbarous methods, the relieving of millions from want and suffering.

No matter what we attempt to do, no matter to what fields we turn our efforts, we are dependent on power. Our economists may propose more economical systems of administration and utilisation of resources, our legislators may make wiser laws and treaties, it matters little; that kind of help can be only temporary. If we want to reduce poverty and misery, if we want to give to every deserving individual what is needed for a safe existence of an intelligent being, we want to provide more machinery, more power. Power is our mainstay, the primary source of our many-sided energies. With sufficient power at our disposal we can satisfy most of our wants and offer a guaranty for safe and comfortable existence to all, except perhaps to those who are the greatest criminals of all - the voluntarily idle.

The development and wealth of a city, the success of a nation, the progress of

the whole human race, is regulated by the power available. Think of the victorious march of the British! Apart from the qualities of the race, which have been of great moment, they owe the conquest of the world to - coal. For with coal they produce their iron; coal furnishes them light and heat; coal drives the wheels of their immense manufacturing establishments, and coal propels their conquering fleets. But the stores are being more and more exhausted, and labour is getting dearer and dearer, and the demand is continuously increasing.

It must be clear to every one that soon some new source of power supply must be opened up, or that at least the present methods must be materially improved. A great deal is expected from a more economical utilisation of the stored energy of the carbon in a battery; but while the attainment of such a result would be hailed as a great achievement, it would not be as much of an advance towards the ultimate and permanent method of obtaining power as some engineers seem to believe. By reason both of economy and convenience we are driven to the general adoption of a system of energy supply from central stations, and for such purposes the beauties of the mechanical generation of electricity cannot be exaggerated. The advantages of this universally accepted method are certainly so great that the probability of replacing the engine dynamos by batteries is, in my opinion, a remote one, the more so as the high-pressure steam engine and gas engine give promise of a considerably more economical thermodynamic conversion.

Even if we had this day such an economical coal battery, its introduction in central stations would by no means be assured, as its use would entail many inconveniences and drawbacks. Very likely the carbon could not be burned in its natural form as in a boiler, but would have to be specially prepared to secure uniformity in the current generation. A great many cells would be needed to make up the electromotive force usually required. The process of cleaning and renewal, the handling of nasty fluids and gases and the great space necessary for so many batteries would make it difficult, if not commercially unprofitable, to operate such a plant in a city or densely populated district.

Again, if the station be erected in the outskirts, the conversion by rotating transformers or otherwise would be a serious and unavoidable drawback. Furthermore, the regulating appliances and other accessories which would have to be provided would probably make the plant fully as much, if not more, complicated than the present. We might, of course, place the batteries at or near the coal mine, and from there transmit the energy to distant points in the form of high-tension alternating currents obtained from rotating transformers, but even in this most favourable case the process would be a barbarous one, certainly more so than the present, as it would still involve the consumption of material, while, at the same time, it would restrict the engineer and mechanic in the exercise of their beautiful art. As to the energy supply in small isolated places, as dwellings, I have placed my confidence in the development of a light storage battery, involving the use of chemicals, manufactured by cheap water power, such as some carbide of oxygen-hydrogen cell.

But we shall not satisfy ourselves simply with improving steam and explosive engines or inventing new batteries; we have something much better to work for, a greater task to fulfill. We have to evolve means for obtaining energy from stores which are forever inexhaustible, to perfect methods which do not imply consumption and waste of any material whatever. Upon this great possibility, upon this great problem, the practical solution of which means so much for humanity, I have myself concentrated my efforts for a number of years, and a few happy ideas which came to me have inspired me to attempt the most difficult, and given me strength and courage in adversity.

Nearly six years ago my confidence had become strong enough to prompt me to an expression of hope in the ultimate solution of this all-dominating problem. I have

made progress since, and have passed the stage of mere conviction such as is derived from a diligent study of known facts, conclusions and calculations. I now feel sure that the realisation of that idea is not far off. But precisely for this reason I feel impelled to point out here an important fact, which I hope will be remembered.

Having examined for a long time the possibilities of the development I refer to, namely, that of the operation of engines on any point of the earth by the energy of the medium, I find that even under the theoretically best conditions such a method of obtaining power cannot equal in economy, simplicity and many other features the present method, involving a conversion of the mechanical energy of running water into electrical energy and the transmission of the latter in the form of currents of very high tension to great distances. Provided, therefore, that we can avail ourselves of currents of sufficiently high tension, a waterfall affords us the most advantageous means of getting power from the sun sufficient for all our wants, and this recognition has impressed me strongly with the future importance of the water power, not so much because of its commercial value, though it may be very great, but chiefly because of its bearing upon our safety and welfare.

I am glad to say that also in this latter direction my efforts have not been unsuccessful, for I have devised means which will allow us the use in power transmission of electro-motive forces much higher than those practicable with ordinary apparatus. In fact, progress in this field has given me fresh hope that I shall see the fulfillment of one of my fondest dreams; namely, the transmission of power from station to station without the employment of any connecting wire. Still, whatever method of transmission be ultimately adopted, nearness to the source of power will remain an important advantage.

Some of the ideas I have expressed may appear to many hardly realisable; nevertheless, they are the result of long continued thought and work. With ideas it is as with dizzy heights. At first they cause you discomfort and you are anxious to get down, distrustful of your own powers; but soon the remoteness of the turmoil of life and the inspiring influence of the altitude calm your blood; your step gets firm and sure and you begin to look - for dizzier heights.

In the great enterprise at Niagara we see not only a bold engineering and commercial feat, but far more, a giant stride in the right direction as indicated both by exact science and philanthropy. Its success is a signal for the utilisation of water powers all over the world, and its influence upon industrial development is incalculable. We must all rejoice in the great achievement and congratulate the intrepid pioneers who have joined their efforts and means of bring it about. It is a pleasure to learn of the friendly attitude of the citizens of Buffalo and of the encouragement given to the enterprise by the Canadian authorities. We shall hope that other cities, like Rochester on this side and Hamilton and Toronto in Canada, will soon follow Buffalo's lead. This fortunate city herself is to be congratulated. With resources now unequalled, with commercial facilities and advantages such as few cities in the world possess, and with the enthusiasm and progressive spirit of its citizens, it is sure to become one of the greatest industrial centres of the globe.

Electrical Review - N. Y.

Jan. 5, 1898, pp. 8, 9

TESLA'S LATEST ADVANCES IN VACUUM-TUBE LIGHTING.

APPLICATION OF TUBES OF HIGH ILLUMINATING POWER TO PHOTOGRAPHY AND OTHER PURPOSES.

To the Editor of *Electrical Review*:

A few years ago I began a series of experiments with a view of ascertaining the applicability of the light emitted by phosphorescent vacuum tubes to ordinary photography. The results soon showed that, even with a tube giving no more light than the equivalent of one half of a candle, objects could be easily photographed with exposures of a few minutes, and the time could be reduced at will by pushing the tube to a high candlepower. Photographs of persons were likewise obtained at that time and, if I am not mistaken, these were the first likenesses produced with this kind of illumination. However, a number of facts, not pertaining to the subject presently considered, were observed in the course of the experiments which, had they been immediately published, might have materially hastened important scientific developments which have taken place since. To dwell on these and other experimental results obtained at that time, more extensively at the first opportunity, is one of my good resolutions for the coming year. A calamity unfortunately, interrupted my labors for a short period, but as soon as I was able I took up again the thread of the investigation, which was not only interesting in connection with the principal object in view, but was also useful in many other respects. So, for instance, in making observations as to the efficiency or any peculiarity of the vacuum tubes, the photographic plate was found to be an excellent means of comparison, note being taken of the distance and time of exposure, character of the phosphorescent body, degree of rarefaction and other such particulars of the moment.

A rather curious feature in the photographs obtained with tubes of moderate illuminating power, as a few candles, was that the lights and shadows came out remarkably strong, as when very short exposures are made by flashlight, but the outlines were not sharp and practically no detail was visible. By producing tubes of much greater candlepower, a notable improvement in this respect was effected, and this advance prompted me to further efforts in this direction, which finally resulted in the production of a tube of an illuminating power of equal to that of hundreds, and even thousands, of ordinary vacuum tubes. What is more, I believe that I am far from having attained the limit in the amount of light producible, and believe that this method of illumination will be eventually employed for light-house purposes. This probably will be considered the oddest and most unlooked-for development of the vacuum tube.

Simultaneously with this progress a corresponding improvement was made in the efficiency of the light produced. A few words on this point might not be amiss, considering that a popular and erroneous opinion still exists in regard to the power consumed by vacuum tubes lighted by ordinary means. So deeply rooted is this opinion which, I will frankly confess, I myself shared for a long time, that, shortly after my own first efforts, Sir David Solomons and Messrs. Pike & Harris undertook to introduce in England such tubes on a large scale in competition with the incandescent system of lighting. The enterprise, which was commented on in the technical periodicals, was commendable enough, but it was not difficult to foretell its fate; for although the high-frequency currents obtained from the alternator yielded better economical results than interrupted currents, and although they were obtained in a convenient and fairly economical manner, still the efficiency of the whole system was necessarily too small for competition with incandescent lamps. The reason for the great power consumption, which may often be as much as 10 times that taking place in incandescent lamps for an equivalent amount of light, are not far to seek. A vacuum tube, particularly if it be very large.

offers an immense radiating surface, and is capable of giving off a great amount of energy without rising perceptibly in temperature. What still increases the dissipation of energy is the high temperature of the rarefied gas. Generally it is supposed that the particles are not brought to a high temperature, but a calculation from the amount of matter contained in the tube, leads to results which would seem to indicate that, of all the means at disposal for bringing a small amount of matter to a high temperature, the vacuum tube is the most effective. This observation may lead to valuable uses of such tubes in astronomical researches, and a line of experiment to this end was suggested to me recently by Dr. Geo. E. Hale, of the Yerkes Observatory. As compared with these disadvantages the incandescent lamp, crude and inefficient as it undoubtedly is, possesses vastly superior features. These difficulties have been recognized by me early, and my efforts during the past few years have been directed towards overcoming these defects and have finally resulted in material advances, so that I find it possible to obtain from a tube of a volume not much greater than that of a bulb of an incandescent lamp, about the same amount of light produced by the latter, without the tube becoming overheated, which is sure to take place under ordinary conditions. Both of these improvements, the increase of candle-power as well as degree of efficiency, have been achieved by gradual perfection of the means of producing economically harmonical electrical vibrations of extreme rapidity. The fundamental principle involved is now well known, and it only remains to describe the features of the system in detail, a duty with which I expect to be able to comply soon, this being another one of my good resolutions.

The purpose of the present communication is chiefly to give an idea in how far the object here aimed at was obtained. The photographs shown were taken by a tube having a radiating surface of about two hundred square inches. The frequency of the oscillations, which were obtained from an Edison direct-current supply circuit, I estimated to be about two million a second. The illuminating power of the tube approximated about one thousand candles, and the exposures ranged from two to five seconds, the distance of the object being four to five feet from the tube. It might be asked why, with so high an illuminating power, the exposures should not be instantaneous. I would not undertake to satisfactorily answer this question, which was put to me recently by a scientific man, whose visit to my laboratory I still vividly recollect. Likenesses can, of course, be obtained with instantaneous exposures, but it has been found preferable to expose longer and at a greater distance from the tube. The results so far obtained would make it appear that this kind of light will be of great value in photography, not only because the artist will be able to exactly adjust the conditions in every experiment so as to secure the best result, which is impossible with ordinary light. He will thus be made entirely independent of daylight, and will be able to carry on his work at any hour, night or day. It might also be of value to the painter, though its use for such purposes I still consider problematical.

I anticipate that much detail will naturally be lost in the reproductions through the half-tone process and press work, however good, but I hope that enough will be shown to demonstrate the advantageous features of this light in photography and its practical usefulness in this art.

In conclusion, I wish to thank Mr. R. L. Newman for kindly consenting to the use of his photograph.

NIKOLA TESLA
New York, Jan. 3.

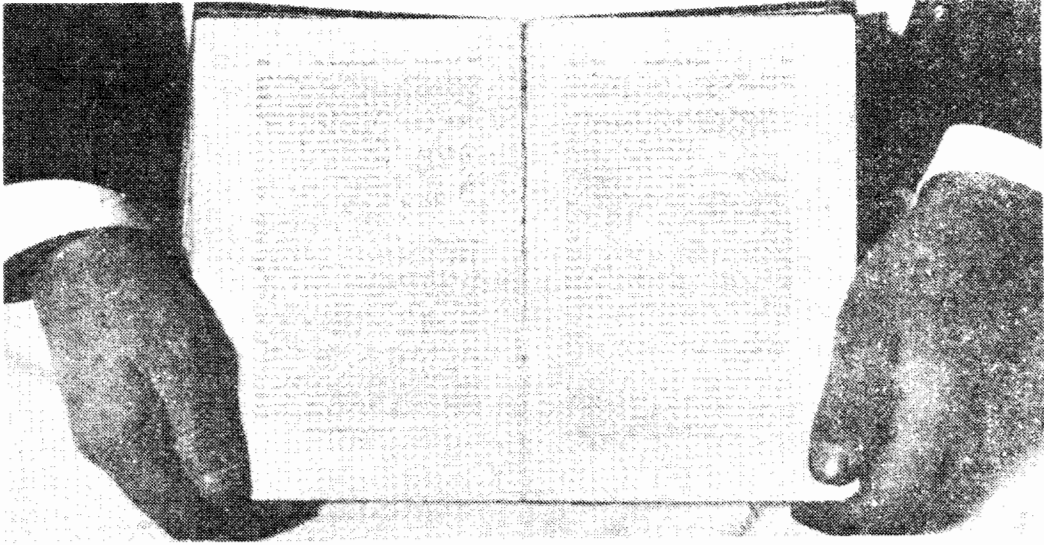

PHOTOGRAPHED BY THE LIGHT OF A SINGLE VACUUM TUBE AT A DISTANCE OF FOUR FEET; EXPOSURE TWO SECONDS.



PHOTOGRAPH OF THE EXPERIMENTER'S HAND MADE BY THE LIGHT OF A SINGLE IMPROVED VACUUM TUBE OF 1,000 CANDLES. EXPOSURE TWO SECONDS; DISTANCE FROM THE TUBE FOUR FEET.



PHOTOGRAPH MADE BY THE LIGHT OF A SINGLE VACUUM TUBE, AT A DISTANCE OF FIVE FEET; EXPOSURE, FIVE SECONDS.

New York Journal
Feb. 6, 1898

TESLA ON ANIMAL TRAINING BY ELECTRICITY.

Ni(c)ola Tesla Writes of the Interesting Possibilities of This New and Successful Device of Animal Trainers in Europe.

To the Editor of the Journal:

It seems to me that there are interesting possibilities in the training of animals by electricity. Of course, it's rather out of my province, but the idea of the electrical subjugator appears feasible when one knows the power of electricity and the instinctive fear that brutes have of the unknown. And the electrical method seems more humane than those I believe are in use - the whip, red hot irons, and drugs, which are likely to do permanent injury, while the physical effects of an electric shock are soon gone, only the moral ones remaining.

The subjugator referred to will do the work, but I think an apparatus could be designed that would be less dangerous to the man. I do not desire to be understood as giving the matter deep thought, but believe that if, instead of the armored back-pad, the trainer used a wand, with two prongs at one end, better results would follow. This wand would be connected with the supply cables and could be applied to any part of the animal's body at will. Its operation would be precisely the same as the subjugator here illustrated, the two prongs supplying the positive and negative poles of contact found in the flattened wires. With this wand an animal could be simply shocked, stunned or killed, as required.

To cure animals of jumping at men in cages, a screen of stout but flexible wire could be stretched between the trainer and his subject, the wires to be alternately positive and negative, and connected through the regulator with the dynamo. After a couple of springs which would hurl him half insensible back into his corner, the taste for unexpected jumps would leave the brute.

[The following article appeared with the above.-Ed.]

Prague, Jan. 22.

Science has come to aid the lion tamer in subduing the wild beast. The red hot iron will, in future, be cast aside as unnecessary and out of date. Live wires, surcharged with electricity that baffle the lion's fiercest assaults, and burn and maim him badly have taken the place of the lash and scorching iron. A lion tamer of Austria, Louis Koemmenich, has been the first to call in the assistance of the lightning to subdue wild beasts.

Koemmenich has invented what he calls the electrical subjugator. This is a shield of electric wires that fasten on the back of the lion tamer and are connected with a dynamo by a wire coil of sufficient length to allow Koemmenich to move around the cage.

In his hand he will carry a charged metal ball on an insulated handle, to be used as the red hot iron was in former days.

The dynamo is operated by an assistant outside of the cage.

Should a lion show a disposition to leap on Koemmenich, he invites attack by deliberately turning his back to the lion and apparently encouraging the onslaught.

When the beast springs his paws come in contact with the electric shield, and he receives a shock of 1,500 volts from the dynamo.

The operator can, if necessary, increase the voltage so as to shock the animal to death.

Thus far the device has worked like magic. One dose of lightning is sufficient for the average lion. Whips and even hot irons they have dared, but no animal has yet troubled Koemmenich after receiving into its body 1,500 volts from the electric subjugator. Whenever Koemmenich enters the cage after an encounter with a lion that has run against the electrical subjugator, he will cower away into a corner of the cage, and never need any further punishment.

New York Journal
Nov. 13, 1898

MY SUBMARINE DESTROYER - by Nikola Tesla

Yesterday Nikola Tesla gave to the Sunday Journal exclusively the news of his latest invention - a submarine torpedo boat. He has perfected his device after observing the defects of the torpedo boats in the recent war, and noting the fatalities of submarine boats invented up to date. His submarine boat will carry no lives to risk, but can be directed at a distance of miles from on shore or from the deck of a war ship. The power to do this will be the electric vibrations of the air used in wireless telegraphy. By this means a whole flotilla of submarine destroyers can be turned against a hostile fleet, and perhaps destroy it, without the enemy knowing how they were attacked. This seems almost incredible until the great magician of electricity explains his wonderful invention, point by point, in the following statement.

"I am now prepared to announce through the Journal my invention of a submarine torpedo boat that I am confident will be the greatest weapon of the navy from this time on.

"The almost utter uselessness of the present kind of torpedo boat has been conclusively demonstrated in the recent war. Neither the courage and skill of the Americans nor the desperate extremities of the Spaniards were able to bring the torpedo boats into successful action. These frail craft, of which so much was expected, simply made an easy target for land batteries and rapid-fire guns of opposing war ships.

"The submarine boats, on the other hand, which have up to this time been built to carry torpedoes have proved death traps for men and were consequently ineffective. The submarine boat, or, more properly speaking, the submarine destroyer, which I have invented is as compact as the torpedo itself. In fact, it is simply an enlarged torpedo shell, thirty-six and a half feet long, loaded with other torpedoes to discharge. Like a torpedo, also, it has its own propelling device. But here the likeness stops. The ordinary torpedo, once launched, plunges head on blindly and no known power can turn it one way or another. It hits or misses, according to the trueness with which it is aimed at its launching.

"But my submarine boat, loaded with its torpedoes, can start out from a protected bay or be dropped over a ship's side, make its devious way below the surface, through dangerous channels of mine beds, into protected harbors and attack a fleet at anchor, or go out to sea and circle about, watching for its prey, then dart upon it at a favorable moment, rush up to within a hundred feet if need be, discharge its deadly weapon and return to the hand that sent it. Yet through all these wonderful evolutions it will be under the absolute and instant control of a distant human hand on a far-off headland, or on a war ship whose hull is below the horizon and invisible to the enemy.

"I am aware that this sounds almost incredible and I have refrained from making this invention public till I had worked out every practical detail of it. In my laboratory I now have such a model, and my plans and description at the Patent Office at Washington show the full specifications of it.

"As to the mechanism which is to be stored in this submarine shell: The first and most essential thing is a motor, with storage battery to drive the propeller. Then there are smaller motors and batteries to operate the steering gear, on the same principle that an ordinary vessel is now steered by steam or electricity. Besides these there are still other storage batteries and motors to feed electric signal lights. But in order that the weight of the machinery shall not be too great to destroy the buoyancy or make the boat go too deep in the water compressed air motors will also be used to perform certain functions, such as to fill and empty the water tanks which raise the boat to the surface or sink it to any required depth. Pneumatic air or motors will also fire the torpedoes and pump out the water that may leak in at any time.

"This submarine destroyer will be equipped with six 14-foot Whitehead torpedoes. These will be arranged vertically in two rows in the bow. As one torpedo falls into position and is discharged by pneumatic force, another torpedo, by the force of gravity, falls into the position of the first one, the others above being held up by automatic arms. They can be fired as rapidly as a self-cocking revolver is emptied or at intervals of minutes or hours. The discharge takes place through a single tube, projecting straight ahead in the bow. The small amount of water which leaks through each time is caught by drain pipes and a compressed air pump instantly expels it. As each torpedo is expelled a buoyancy regulator will open the sea cocks and let enough water in the ballast tanks to make the buoyancy uniform and keep the boat at the same distance beneath the surface.

"This submarine destroyer will carry a charge of torpedoes greater than that of the largest destroyers now in use. Those vessels of five hundred tons each which cost the Government \$500,000, carry but three or four torpedoes, while this simple submarine destroyer, which can be built for \$48,000 to \$50,000 or less, will carry six torpedoes. It will have, also, the incalculable advantage of being absolutely invisible to an enemy, and have no human lives to risk or steam boilers to blow up and destroy itself.

"All that is necessary to make this submarine boat subject to perfect control at any distance is to properly wire it, just like a modern house is wired so that a button here rings a bell, a lever there turns on the lights, a hidden wire somewhere else sets off a burglar alarm and a thermal device give a fire alarm.

"The only difference in the case of the submarine boat is in the delicacy of the instruments employed. To the propelling device, the steering gear, the signal apparatus and the mechanism for firing the torpedoes are attached little instruments which are attuned to a certain electro-magnetic synchronism.

"Then there is a similar set of synchronistic instruments all connected to the little switchboard, and placed either on shore or on an ordinary war ship. By moving the lever on the switchboard I can give the proper impulse to the submarine boat to go ahead, to reverse, throw the helm to port or starboard, rise, sink, discharge her torpedoes or return.

"It might be thought that some great power would be necessary to be projected across miles of distance and operate on the far-off boat. The power is all stored in the submarine boat itself - in its storage batteries and compressed air. All that is needed to affect the synchronistic instruments is a set of high alternating currents, which can be produced by my oscillator attached to any ordinary dynamo situated on shore or on a war ship.

"How such an apparently complicated mechanism can be operated and controlled at a distance of miles is no mystery. It is as simple as the messenger call to be found in almost any office. This is a little metal box with a lever on the outside. By moving the crank to a certain point it gives vibrating sounds and springs back into position, and its momentary buzzing calls a messenger. But move this same crank a third further around the dial and it buzzes still longer, and pretty soon a policeman appears, summoned by its mysterious call. Again, move the crank this time to the farthest limit of the circle and scarcely has its more prolonged hum of recoil sounded when the city fire apparatus dashes up to your place at its call.

"Now, my device for controlling the motion of a distant submarine boat is exactly similar. Only I need no connecting wires between my switchboard and the distant submarine boat, for I make use of the now well-known principle of wireless telegraphy. As I move this little lever to points which I have marked on a circular dial I cause a different number of vibrations each time. In this case two waves go forth at each half turn of the lever and affect different parts of the distant destroyer's machinery.

"How such submarine destroyers should actually be used in war I leave for naval tacticians to determine. But it seems to me that they could best be operated by taking a number on board a large fast auxiliary cruiser like the St. Louis or St. Paul, launch them, several at a time, like life boats, and direct their movements from a switch board placed in the forward fighting top.

"In order that the director of the submarine destroyer may know its exact position at every movement, two masts, at bow and stern, will project up just above the water, too minute to be seen or hit by an enemy's guns by day, and by night they will carry hooded lights.

"The lookout placed in the fighting top could detect a hostile ship off on the horizon while the auxiliary cruiser's big hull is still invisible to the enemy. Starting these little destroyers out under direction of a man with a telescope, they could attack and destroy a whole armada - destroy it utterly - in an hour, and the enemy never have a sight of their antagonists or know what power destroyed them. A big auxiliary cruiser, used to carry these submarine destroyers, could also carry a cargo of torpedoes sufficient to conduct a long campaign and go half way around the world.

"She could carry the gun cotton and other explosives needed to load the torpedoes in safe magazines below the water line, and do away with much of the danger of transporting loaded torpedoes. When necessary for use the war heads could be loaded, fitted to the torpedoes, and the submarine destroyers fully equipped.

"A high, projecting headland overlooking a harbor and the sea would also be a good point on which to establish a station and have the destroyers laid up at docks below ready to start.

"That is the whole story of my latest invention. It is simple enough, you say. Of course it is, because I have worked all my life to make each one of the details so simple that it will work as easily as the electric ticker in a stock broker's office.

Electrical Engineer - N. Y.
Nov. 24, 1898, p. 514

New York, Nov. 18, 1898
46 & 48 East Houston St.

Editor of The Electrical Engineer, 120 Liberty St., New York City:

Sir - By publishing in your columns of Nov. 17 my recent contribution to the Electro-Therapeutic Society you have finally succeeded - after many vain attempts made during a number of years - in causing me a serious injury. It has cost me great pains to write that paper, and I have expected to see it appear among other dignified contributions of its kind, and I confess, the wound is deep. But you will have no opportunity for inflicting a similar one, as I propose to take better care of my papers in the future. In what manner you have secured this one in advance of other electrical periodicals who had an equal right to the same, rests with the secretary of the society to explain.

Your editorial comment would not concern me in the least, were it not my duty to take note of it. On more than one occasion you have offended me, but in my qualities both as Christian and philosopher I have always forgiven you and only pitied you for your errors. This time, though, your offence is graver than the previous ones, for you have dared to cast a shadow on my honor.

No doubt you must have in your possession, from the illustrious men whom you quote, tangible proofs in support of your statement reflecting on my honesty. Being a bearer of great honors from a number of American universities, it is my duty, in view of the slur thus cast upon them, to exact from you that in your next issue you produce these, together with this letter, which in justice to myself, I am forwarding to other electrical journals. In the absence of such proofs, I require that, together with the preceding, you publish instead a complete and humble apology for your insulting remark which reflects on me as well as on those who honor me.

On this condition I will again forgive you; but I would advise you to limit yourself in your future attacks to statements for which you are not liable to be punished by law.

N. TESLA

Electrical Review - N. Y.
Nov, 30, 1898, pp. 344, 345

TESLA DESCRIBES HIS EFFORTS IN VARIOUS FIELDS OF WORK.

(From *The Sun*, New York, November 21, 1898)

TO THE EDITOR OF THE SUN - Sir: Had it not been for other urgent duties, I would before this have acknowledged your highly appreciative editorial of November 13. Such earnest comments and the frequent evidences of the highest appreciation of my labors by men who are the recognized leaders of this day in scientific speculation, discovery and invention are a powerful stimulus, and I am thankful for them. There is nothing that gives me so much strength and courage as the feeling that those who are competent to judge have faith in me.

Permit me on this occasion to make a few statements which will define my position in the various fields of investigation you have touched upon.

I can not but gratefully acknowledge my indebtedness to earlier workers, as Dr. Hertz and Dr. Lodge, in my efforts to produce a practical and economical lighting system on the lines which I first disclosed in a lecture at Columbia College in 1891. There exists a popular error in regard to this light, inasmuch as it is believed that it can be obtained without generation of heat. The enthusiasm of Dr. Lodge is probably responsible for this error, which I have pointed out early by showing the impossibility of reaching a high vibration without going through the lower or fundamental tones. On purely theoretical grounds such a result is thinkable, but it would imply a device for starting the vibrations of unattainable qualities, inasmuch as it would have to be entirely devoid of inertia and other properties of matter. Though I have conceptions in this regard, I dismiss for the present this proposition as being impossible. We can not produce light without heat, but we can surely produce a more efficient light than that obtained in the incandescent lamp, which, though a beautiful invention, is sadly lacking in the feature of efficiency. As the first step toward this realization, I have found it necessary to invent some method for transforming economically the ordinary currents as furnished from the lighting circuits into electrical vibrations of great rapidity. This was a difficult problem, and it was only recently that I was able to announce its practical and thoroughly satisfactory solution. But this was not the only requirement in a system of this kind. It was necessary also to increase the intensity of the light, which at first was very feeble. In this direction, too, I met with complete success, so that at present I am producing a thoroughly serviceable and economical light of any desired intensity. I do not mean to say that this system will revolutionize those in use at present, which have resulted from the co-operation of many able men. I am only sure that it will have its fields of usefulness.

As to the idea of rendering the energy of the sun available for industrial purposes, it fascinated me early but I must admit it was only long after I discovered the rotating magnetic field that it took a firm hold upon my mind. In assailing the problem I found two possible ways of solving it. Either power was to be developed on the spot by converting the energy of the sun's radiations or the energy of vast reservoirs was to be transmitted economically to any distance. Though there were other possible sources of economical power, only the two solutions mentioned offer the ideal feature of power being obtained without any consumption of material. After long thought I finally arrived at two solutions, but on the first of these, namely, that referring to the development of power in any locality from the sun's radiations, I can not dwell at present. The system of power transmission without wires, in the form in which I have described it recently, originated in this manner. Starting from two facts that the earth was a conductor insulated in space, and that a body can not be charged without causing an equivalent displacement of electricity in the earth, I undertook to construct a machine suited for creating as large a displacement as possible of the earth's electricity.

This machine was simply to charge and discharge in rapid succession a body insulated in space, thus altering periodically the amount of electricity in the earth, and consequently the pressure all over its surface. It was nothing but what in mechanics is a pump, forcing water from a large reservoir into a small one and back again. Primarily I contemplated only the sending of messages to great distances in this manner, and I described the scheme in detail, pointing out on that occasion the importance of ascertaining certain electrical conditions of the earth. The attractive feature of this plan was that the intensity of the signals should diminish very little with the distance, and, in fact, should not diminish at all, if it were not for certain losses occurring, chiefly in the atmosphere. As all my previous ideas, this one, too, received the treatment of Marsyas, but it forms, nevertheless, the basis of what is now known as "wireless telegraphy." This statement will bear rigorous examination, but it is not made with the intent of detracting

from the merit of others. On the contrary, it is with great pleasure that I acknowledge the early work of Dr. Lodge, the brilliant experiments of Marconi, and of a later experimenter in this line, Dr. Slaby, of Berlin. Now, this idea I extended to a system of power transmission, and I submitted it to Helmholtz on the occasion of his visit to this country. He unhesitatingly said that power could certainly be transmitted in this manner, but he doubted that I could ever produce an apparatus capable of creating the high pressures of a number of million volts, which were required to attack the problem with any chance of success, and that I could overcome the difficulties of insulation. Impossible as this problem seemed at first, I was fortunate to master it in a comparatively short time, and it was in perfecting this apparatus that I came to a turning point in the development of this idea. I, namely, at once observed that the air, which is a perfect insulator for currents produced by ordinary apparatus, was easily traversed by currents furnished by my improved machine, giving a tension of something like 2,500,000 volts. A further investigation in this direction led to another valuable fact; namely, that the conductivity of the air for these currents increased very rapidly with its degree of rarefaction, and at once the transmission of energy through the upper strata of air, which, without such results as I have obtained, would be nothing more than a dream, became easily realizable. This appears all the more certain, as I found it quite practicable to transmit, under conditions such as exist in heights well explored, electrical energy in large amounts. I have thus overcome all the chief obstacles which originally stood in the way, and the success of my system now rests merely on engineering skill.

Referring to my latest invention, I wish to bring out a point which has been overlooked. I arrived, as has been stated, at the idea through entirely abstract speculations on the human organism, which I conceived to be a self-propelling machine, the motions of which are governed by impressions received through the eye. Endeavoring to construct a mechanical model resembling in its essential, material features the human body, I was led to combine a controlling device, or organ sensitive to certain waves, with a body provided with propelling and directing mechanism, and the rest naturally followed. Originally the idea interested me only from the scientific point of view, but soon I saw that I had made a departure which sooner or later must produce a profound change in things and conditions presently existing. I hope this change will be for the good only, for, if it were otherwise, I wish that I had never made the invention. The future may or may not bear out my present convictions, but I can not refrain from saying that it is difficult for me to see at present how, with such a principle brought to great perfection, as it undoubtedly will be in the course of time, guns can maintain themselves as weapons. We shall be able, by availing ourselves of this advance, to send a projectile at much greater distance, it will not be limited in any way by weight or amount of explosive charge, we shall be able to submerge it at command, to arrest it in its flight, and call it back, and to send it out again and explode it at will, and, more than this, it will never make a miss, since all chance in this regard, if hitting the object of attack were at all required, is eliminated. But the chief feature of such a weapon is still to be told; namely, it may be made to respond only to a certain note or tune, it may be endowed with selective power. Directly such an arm is produced, it becomes almost impossible to meet it with a corresponding development. It is this feature, perhaps, more than in its power of destruction, that its tendency to arrest the development of arms and to stop warfare will reside. With renewed thanks, I remain,

Very truly, yours,

N. TESLA.

New York, November 19.

Electrical Review - N. Y.
March 29, 1899, pp. 195-197, 204.

SOME EXPERIMENTS IN TESLA'S LABORATORY WITH CURRENTS OF HIGH POTENTIAL AND HIGH FREQUENCY.

To the Editor of *Electrical Review*:

Since the unfortunate accident of four years ago, which crippled and delayed my labors in a number of lines so seriously, I have had but little time to devote to the fulfillment of a duty which, next to that of turning his best efforts to diligent inquiry in the fields he has chosen, is the most important to a scientific man; namely, that of giving an exact record of the results obtained. I realize with sorrow every day that, despite of all pains taken to this end, I am gaining but very slowly on the material accumulated. Ideas come through a happy inspiration, apparently without much exertion, but it is the working out of the many harassing details and putting into a presentable form which consumes time and energy. It was impossible to abandon research in new directions, in which I have felt myself irresistibly drawn, and it was equally impossible to do full justice to the work partially completed, and I can only hope to gradually retrieve my losses by the only expedient available, which is to redouble the zeal. It is not the best plan to follow, I confess, and is in radical opposition to the kindly advice given to me to the effect that I intended to live 200 years by sleeping most of the time! It may also show that it is not this mode of life which is responsible for the delay in the commercial introduction of my system of vacuum tube lighting, as has been asserted by some people who have found a singular satisfaction in dwelling extensively in their columns on my proposed glass house on Long Island, which was to cover acres of ground, and which was to be built for the purpose of catching the sun's rays; on my claims of the discoveries of Roentgen; on my invention enabling me to move and explode torpedo boats by will power, and on my efforts to annihilate the entire British navy. It is to be hoped that the limit of patience of the readers has been finally reached.

At that time, still painfully remembered, my energies were taken up principally by some mechanical problems of great importance, and the few observations in electricity which I was fortunate to make came like ever so many refreshing berries found on the road by a weary wanderer. The journey is not finished yet, and the wanderer is well-nigh exhausted. He longs for more sweet berries, and anxiously asks, "Did any one pass this road before?"

It was chiefly in three directions that electrical investigation was attractive and promising: There were the excessive electrical pressures of millions of volts, which opened up wonderful possibilities if producible in practical ways; there were currents of many hundreds of thousands of amperes, which appealed to the imagination by their astonishing effects, and, most interesting and inviting of all, there were the powerful electrical vibrations with their mysterious actions at a distance. What better work could one do than inventing methods and devising means for enabling scientific men to push investigation far out into these practically unknown regions? This work was difficult and tedious and involved a certain amount of material sacrifice, but promised a higher reward if successfully accomplished - the gratitude of those many who exercise their gifts in different directions and are compelled to rely on the expert for providing them with implements suitable for their special purpose. Who can estimate how much science has been advanced by the beautiful instruments of measure which Lord Kelvin has given us? Unfortunately, in many of the new fields such instruments are yet to be invented. Still more unfortunately, information seems to be more needful than instruments, if one is to judge from statements frequently made in technical periodicals on a variety of subjects. An experimenter, for instance, measures the current through a make-and-break device, and, finding it small, he infers that the conversion is economical. Another suggests

to determine the efficiency of conversion through such a device by the calorimetric method. Now, as a matter of fact, if there was such a contrivance, absolutely perfect in its action, which would behave as I have explained on another occasion, and change the resistance of a gap from zero to infinity without any loss in the gap itself, which separates the terminals, it still might happen that 99 per cent of the energy supplied to the circuit would be wasted in radiations, useless for the purpose contemplated. The calorimetric method would in this, or generally in any other instance, in which the disturbances produced are very sudden, entirely fail in giving an approximation as to the energy dissipated in the circuit, for the simple reason that the friction encountered by a wave in its passage through a medium, which determines the amount of heat generated, is no measure whatever of the energy of the wave. Thus, certain well understood cases excepted, the only method at present available in such estimates is to take account of the energy consumed by the source of supply. This remark alone will show that the economical conversion of currents by make and break devices is a much more difficult problem than it appears to those who have studied it superficially. Not only must the devices used in the transformation possess certain characteristics, but the entire circuit must be properly designed. One can not help admiring the confidence and self-possession of experimenters, who put forth carelessly such views and who, with but a few days', not to say hours', experience with a device, apparently unmindful of the responsibility of such a step, and advance their imperfect results and opinions hastily formed. The sparks may be long and brilliant, the display interesting to witness, and the audience may be delighted, but one must doubt the value of such demonstrations. There is so little novelty in them, that one might easily perform a practical joke on the lecturer by describing in advance all his drawings, apparatus, experiments and theories, this placing him in an awful predicament. Though such a course would be naturally impolite, it might be found justified and excused by the circumstances, for premature expressions of opinion and demonstrations of this kind are responsible for much evil, one of these being the erroneous idea which they create in scientific circles as to the importance of an advance made. It grieves one to observed that, for example, such great work as that of Professor Dewar, which he turns out with clock regularity, is scarcely commented upon in the technical columns, whereas a worthless trap for interrupting currents, which usually consumes nine-tenths of the energy, and is, besides, useless for other reasons, and just suitable for the amusement of small boys, who are beginning their electrical experience with Leclanche batteries and \$1.50 induction coils, is hailed as an important scientific discovery. An agreeable contrast is afforded by those who patiently investigate, contented to lose the credit for advances made rather than to present them to the world in an imperfect state, who form their opinions conscientiously, after a long and careful study, and have little to correct afterward.

The importance of the task of providing proper implements for research in these fields once recognized, it became the question in what line the efforts to this end would be likely to be most profitable. A little thought showed that it was in investigating high electrical pressures, for these were needed in most instances. More than a passing thought was given to static electricity, with the experiments of Franklin as starting point. Various forms of generators of static electricity were experimented upon, and some new ones designed, to which I hope to revert some time, as they present some features of interest. The most valuable outcome of these experiments was a method of conversion which I have described, and which enables the operation of any kind of devices of low tension from such a high-pressure source with perfect ease and safety, no matter how high the tension. Soon, however, it was recognized that with the above object in view generators of steady pressure were entirely impractical, quite apart from their incidental limitations. It was exactly as if one attempted to drive piles into the ground by the application of continuous pressure. This would require cumbersome and powerful machinery, and would be very

inconvenient. An incomparably better way of developing high pressure is by delivering violent blows as with a hammer. In such a case the motion of the hammer being suddenly arrested pressure is developed on the point of impact, which is all the greater the smaller the displacement caused, and if there were material absolutely rigid, incompressible and inelastic, an infinite pressure might thus be developed by a small blow. Hence one is forcibly driven to the use of a transformer or induction coil as means for producing great electrical pressures. The first difficulty encountered was that of insulation, and it might be interesting and useful to show, chiefly to those who are less familiar with this special subject, how by gradual improvement, from the ordinary inductorium capable of furnishing currents of very moderate electro-motive force, an apparatus was finally evolved in which there is practically no limit as to the pressure obtainable.

Selecting first the closed core transformer, one easily recognizes that it is unsuitable for the attainment of the object in view for obvious reasons. Nevertheless, by adopting the plan illustrated in the first diagram of Fig. 2, I succeeded in obtaining nearly 200,000 volts, and I think that more than twice this tension is practicable by means of such an arrangement, which involves the use of independent and entirely insulated sources of supplying the primaries, as will be understood from an inspection of the diagram without further explanation. The evident limitations of the closed-core type in the way of insulation, rate of change and frequency of the current impulses, led to the adoption of an open-core type, as a matter of course, and the various diagrams of the figure referred to illustrate the modifications as they were gradually made in the manner of insulating and winding of the coils. In diagram 2 the old, primitive method of insulation is indicated. In diagram 3 the succeeding layers are insulated by material increasing in thickness gradually from one end to the other, being thickest on the place of greatest difference of potential. The thickness is easily calculated beforehand, and is such that all the insulation is as nearly as possible uniformly strained. As it was impracticable to pile up many layers in the manner illustrated in diagram 3, naturally the modification illustrated in diagram 4 was made, which led to a further improvement, indicated in diagram 5. It was recognized, however, that there was no advantage in winding many coils, and that all that was needed were two secondary coils joined in the middle, as illustrated in diagram 6, the secondaries being, of course, wound as shown in diagram 3. Next, in order to increase the output of the coil and gain other advantages, the relative customary position of the primary and secondary windings was reversed and the coil as shown in diagram 7 produced, the two secondary coils being joined on their outer, instead of on their inner ends, as before. This construction was considerably better than that illustrated in diagram 6, as the primary and secondary coils were placed in closer inductive relation. But when with this coil the tension had been pushed far enough, it was found that the iron core limited the spark length, and then two insulated cores, one in each coil, were resorted to, which were finally discarded, and so the coil shown in diagram 8 resulted, which I have described on several occasions and which, of all other constructions, permits the obtainment of the highest possible tension with a two-terminal coil in a given space.

But even in this perfected type it was not possible to go beyond a certain potential difference, and a further investigation led to a new type, which I have called a single terminal coil, and which is illustrated in diagram 9 and is now well known. In this coil the adjustment is so made that the secondary is nearly equal to the quarter of the wave length, the highest potential being, under these conditions, produced on the free terminal. Subsequently I extended such adjustment also to the coils in diagram 8, improving the same materially.

During these efforts I fortunately discovered the important part which air played in the breaking down of the insulation, and by adopting proper methods for the exclusion of gaseous matter, I was able to increase the electro-motive force to more than 10 times the value without breaking down the secondary. I have described this

method since, which I am using in the manufacture of coils and condensers, and without which it would be entirely impossible to reach any such results as I have obtained. The industrial world has profited by the recognition of the action of the air, for it has helped to extend power transmission to greater distances than heretofore practicable. It has also been useful in determining the limits of the electro-motive forces with ordinary apparatus used in power transmission, but I see that no attempt is yet made to overcome the streamers by a suitable construction of the cables, as I have indicated, and thus make higher electro-motive forces available.

Further experimentation with the original single-terminal coil, before referred to, finally led step by step to the adoption of a coil of large dimensions, which, in two typical forms, is illustrated in diagrams 10 and 11. With such a coil I found that there was practically no limit to the tension available, and it is by its means that I discovered the most important of all facts arrived at in the course of my investigation in these fields. One of these was that atmospheric air, though ordinarily a perfect insulator, conducted freely the currents of immense electro-motive force producible by such coils and suitable accessories. So great is the conductivity of the air, that the discharge issuing from a single terminal behaves as if the atmosphere were rarefied. Another fact is that this conductivity increases very rapidly with rarefaction of the atmosphere and augmentation of the electrical pressure, to such an extent that at barometric pressures which permit of no transit of ordinary currents, those generated by such a coil pass with great freedom through the air as through a copper wire. Following up these promising revelations I demonstrated conclusively by experiments that great amounts of electrical energy can be transmitted to any distance through upper air strata which are easily accessible, and since this truth has been recognized every fiber has been strained to realize such a transmission on a large scale. These two observations explain clearly the silent discharges noted frequently in dense air strata, but three or four miles above the earth's surface. One more equally important fact I may mention, which was simultaneously observed. The discharges of such a coil, when of an electro-motive force of a few millions of volts, excite powerful affinities in the atmospheric nitrogen, causing it to combine readily with the oxygen and other elements, particularly in the presence of aqueous vapor. So energetic are these actions and so strangely do such powerful discharges behave, that I have often experienced a fear that the atmosphere might be ignited, a terrible possibility, which Sir William Crookes, with his piercing intellect, has already considered. Who knows but such a calamity is possible? And who can tell with certitude that periodical cessations of organic life on the globe might not be caused by ignition of the air and destruction of its life-sustaining qualities, accidentally or as a consequence of some accumulative change? A lump of coal will lie for centuries unaffected in contact with oxygen, but the combustion once started, the process continues as long as there are elements to combine.

While improving the construction of the transformers, every effort was made to perfect the apparatus for generating the currents. The objective point from the outset was to obtain the greatest possible rate of variation. High-frequency alternators were first used, but their limitations were soon apparent. I then turned again and again to make and break devices, chiefly with the object of using them in connection with a novel form of transformer, which I have previously described, and which is now well known and understood. In its original form, as I first showed it, it is illustrated in diagram 12, which need not be dwelt upon, beyond saying that one of the characteristic features of such an instrument is the energizing of the primary of the induction coil by the rapidly succeeding discharges of a condenser. In a more recent type, specially adapted for ordinary supply circuits, which I have described and shown before several scientific societies, the transformer comprises, as indicated in diagram 13, three coils, there being, in addition to

the primary and secondary coils, one which receives the currents from the supply circuit, and is designated the charging coil. Preferably the latter is not in inductive relation with the former. On a number of occasions I have described high-frequency apparatus embodying this beautiful method, which has already been of great value to science in my hands as well as in those of others. But a defect, to which I called attention early, still confronted me. It lay in the make and break devices which performed the function of charging and discharging the condenser. Many of such devices, based on a variety of principles, formed the subject of experiments carried on with the aim of doing away with this imperfection. To cite one of these, the current from the source of supply was passed through a minute column of conducting liquid maintained in a variety of ways, and in this simple manner rapidly succeeding impulses were obtained. Incidentally, some useful results were secured with these contrivances, as, for example, the generation of currents of differing phase and the production of rotating fields moving with constant velocity; but, interesting as these simple devices were, they naturally precluded the possibility of economical conversion. Their study, however, was useful as a means of recognizing the requirements of such make and break apparatus, and, finally, led to forms based on scientific and economical principles. A number of these were recently described in technical periodicals and, as stated on a former occasion, they fulfill their difficult duty surprisingly well and make it possible to obtain currents of very high frequency from ordinary supply circuits with great economy. These novel contrivances lend themselves well also to the uses of the ordinary induction coil, and I have employed them with equal success in a form of Plante's rheostatic machine and for many other useful purposes. Thus, after a continuous effort extending through a number of years, I have the supreme satisfaction of having carried this hard and important task to a satisfactory end.

The annexed photographs will serve to convey an idea of what can be done with these perfected implements. Referring to Fig. 1, illustrative of the high rate of change obtained in the current, a vacuum bulb of about 12 inches in diameter is held in front of a coil of four turns of specially constructed heavy cable, through which a condenser is discharging, and, although at a distance of several inches from the coil, the gas in the bulb is brought to intense incandescence, the light emitted being fully equal to 1,500 candles. Such a powerfully energized coil, when the frequency, as in this instance, is measured in millions per second, shows little repellent action, but when the frequency of the impulses is low, closed conductors, as washers of conducting material, are thrown off with a force of a magnitude which can be only explained on the assumption that the currents have maximum values of many hundred thousand amperes.

The remaining photographs will be understood from the titles, which are made explicit for this purpose. I hope to have in the near future an opportunity for describing more of such experiments, and dwelling in detail on the apparatus used. For the present I am compelled, for want of time, to merely state that the vibrations used in most of them were from 400,000 to 800,000 per second.

In conclusion I wish to apologize for the frequent appearance of my likeness in these photographs, which is distasteful to me, but was unavoidable. Most of the advances indicated, and a number of others, have resulted from the application of the beautiful principle upon which the operation of this apparatus is based. Scientific men have honored me by identifying it with my name, and I have earnestly endeavored to show myself worthier of this great distinction by devoting to it much of my energies. No desire for material advantages has animated me in all this work, though I hope, for the sake of the continuance of my labors, that these will soon follow, naturally, as a compensation for valuable services rendered to science and industry. To the scientific experts, who are familiar, in theory and experiment, with electrical vibrations, the results here shown will, I believe, speak in eloquent language. But those readers to whom they are naturally less intelligible will ask: What are



FIG. 1 - LIGHTING A DISCONNECTED VACUUM BULB OF 1,500 CANDLE POWER BY HIGH-FREQUENCY CURRENTS - PHOTOGRAPH TAKEN BY THE LIGHT OF THE BULB ITSELF, EXPOSURE ABOUT TWO SECONDS.

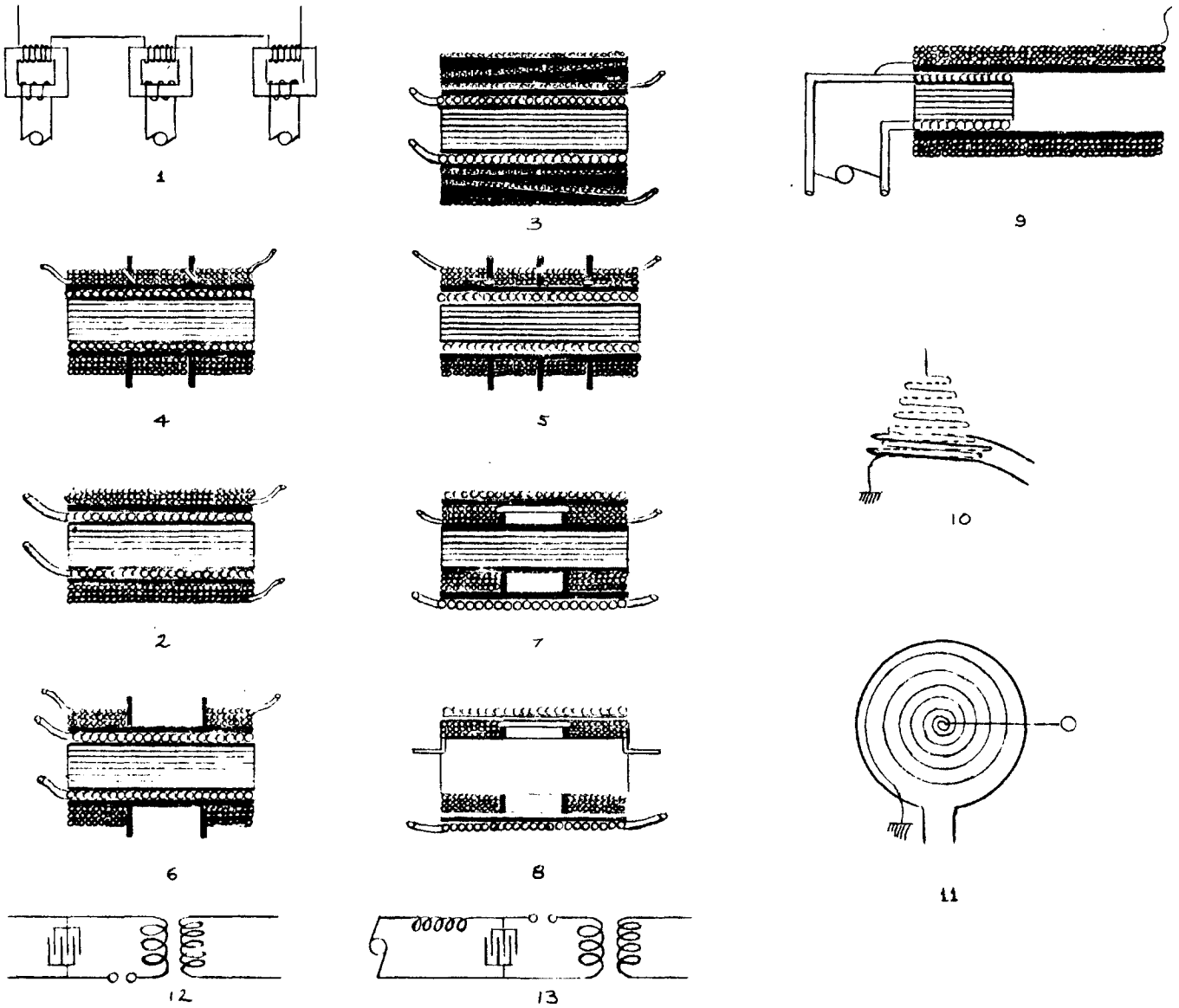

FIG. 2 - TABLE OF DIAGRAMS ILLUSTRATING THE EVOLUTION OF A HIGH-TENSION TRANSFORMER ENABLING THE PRODUCTION OF ELECTRO-MOTIVE FORCES OF MANY MILLIONS OF VOLTS.

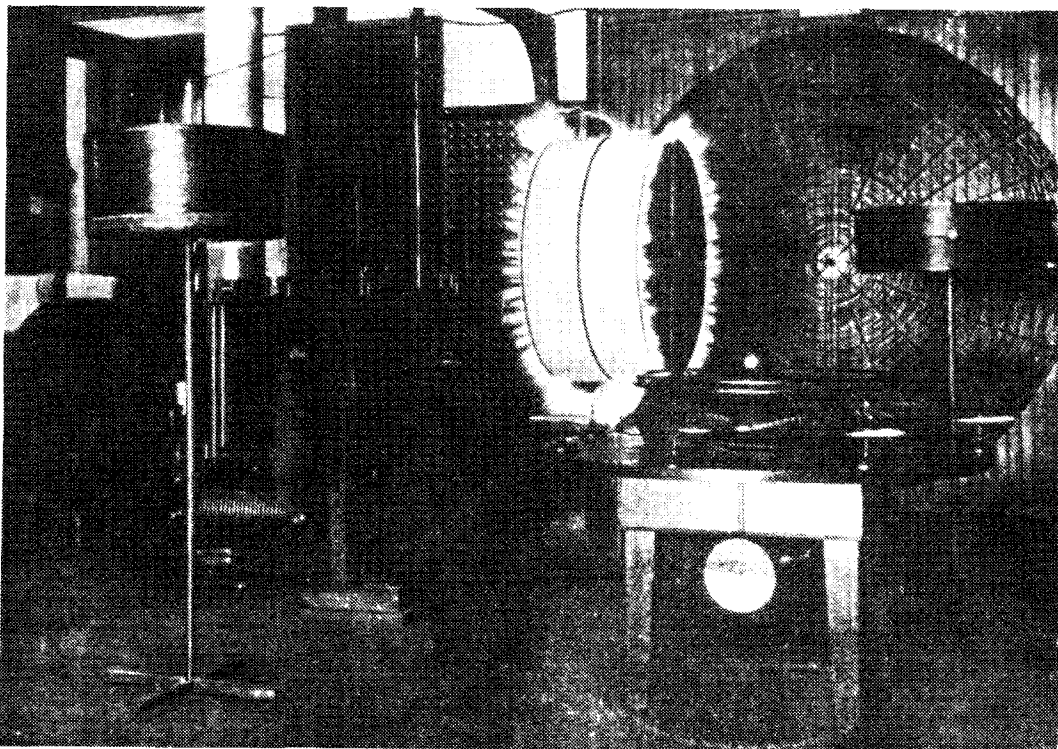

FIG. 3 - PHOTOGRAPH SHOWING A PART OF THE LABORATORY, WITH A DISCONNECTED RESONATING COIL SUPPORTED ON AN INSULATING STAND, AND ILLUMINATED BY THE STREAMERS PRODUCED, OTHER COILS REMAINING UNAFFECTED - THE PRESSURE DEVELOPED IN THE RESONATING COIL IS OVER HALF A MILLION VOLTS.

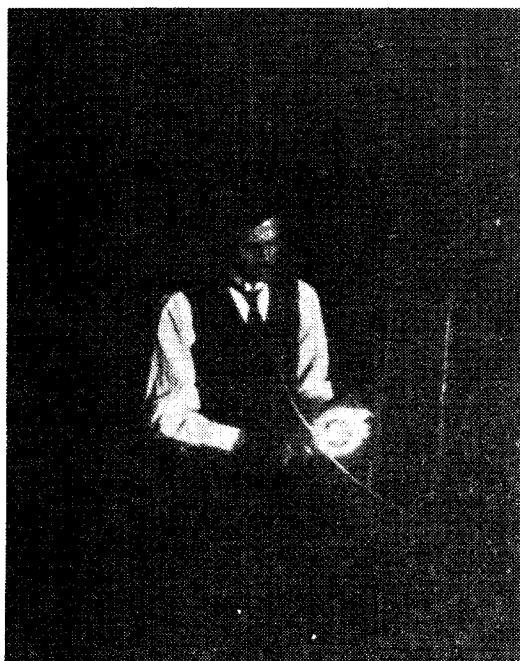

FIG. 4 - PHOTOGRAPH SHOWING AN INCANDESCENT LAMP LIGHTED BY A SYNCHRONIZED CIRCUIT COMPOSED OF A WIRE LOOP AND CONDENSER, AND ENERGIZED BY WAVES TRANSMITTED FROM A DISTANCE.

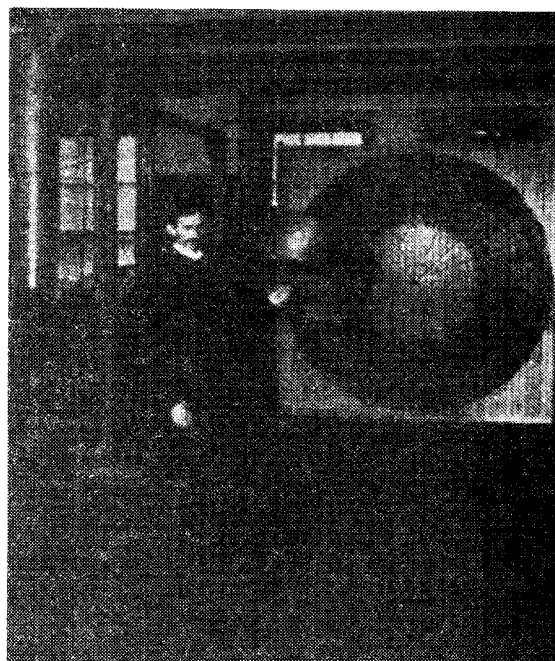

FIG. 5 - PHOTOGRAPH SHOWING AN INCANDESCENT LAMP LIGHTED BY MEANS OF WAVES TRANSMITTED THROUGH SPACE TO A COIL WITHOUT A CONDENSER.

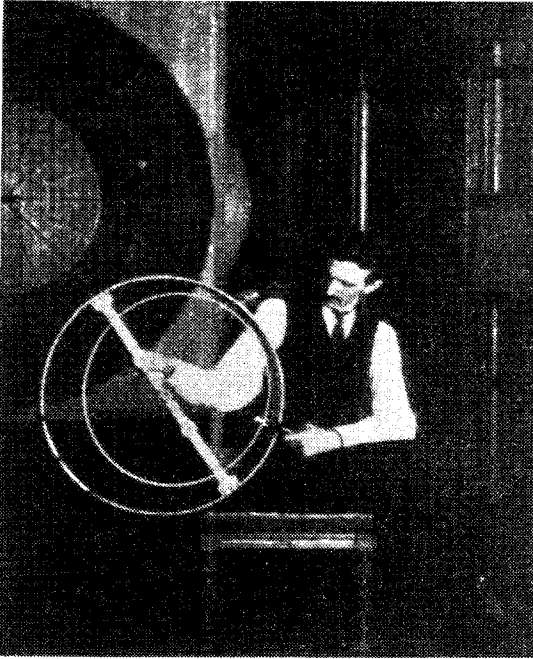

FIG. 6 - EXPERIMENT ILLUSTRATING THE ACTION OF A SYNCHRONIZED CIRCUIT ENERGIZED BY WAVES TRANSMITTED FROM A DISTANT OSCILLATOR - THE ENERGY RECEIVED IS TRANSFERRED UPON ANOTHER UNRESPONSIVE CIRCUIT, LIGHTING THE INCANDESCENT LAMP ATTACHED TO THE SAME.

FIG. 7 - EXPERIMENT SHOWING A COIL ENERGIZED BY THE WAVES OF A DISTANT OSCILLATOR AND ADJUSTED TO THE CAPACITY OF THE BODY OF THE OPERATOR, WHO PRESERVES HIMSELF FROM INJURY BY MAINTAINING A POSITION AT THE NODAL POINT, WHERE THE INTENSE VIBRATION IS LITTLE FELT - THE PRESSURE ON THE END OF THE COIL TOWARDS THE READER, WHICH IS ILLUMINATED BY THE POWERFUL STREAMERS, IS NEARLY HALF A MILLION VOLTS.

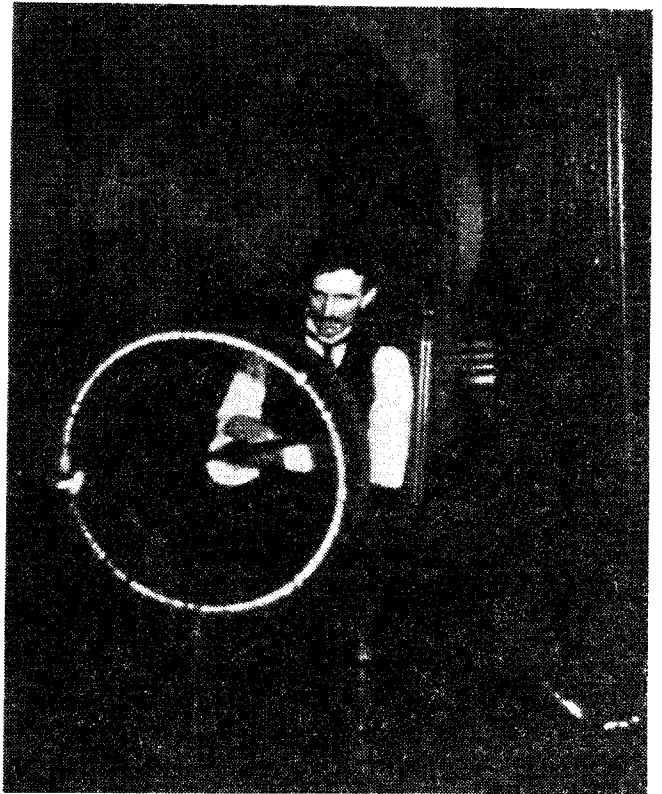
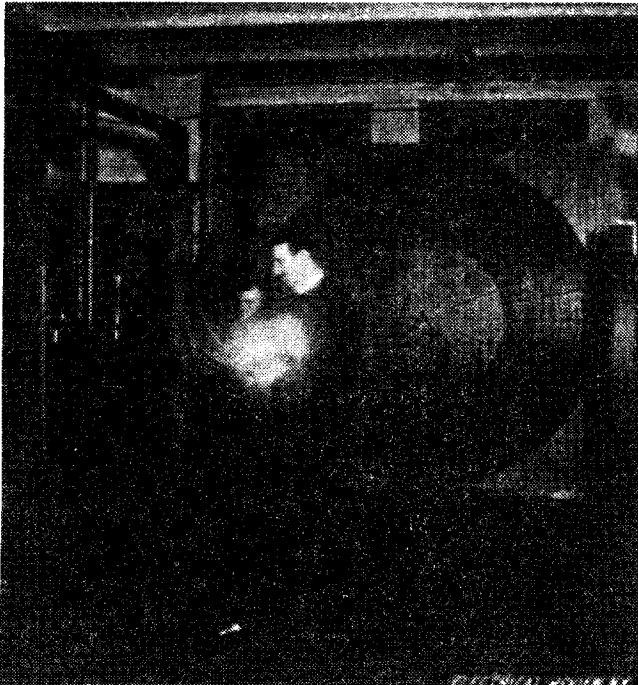

FIG. 8 - PHOTOGRAPH OF THE EXPERIMENTER STANDING IN THE MIDDLE OF THE LABORATORY AND LIGHTING A VACUUM BULB BY WAVES FROM A DISTANT OSCILLATOR - HIS BODY IS, IN THIS CASE, SUBJECTED TO GREAT ELECTRICAL PRESSURE.



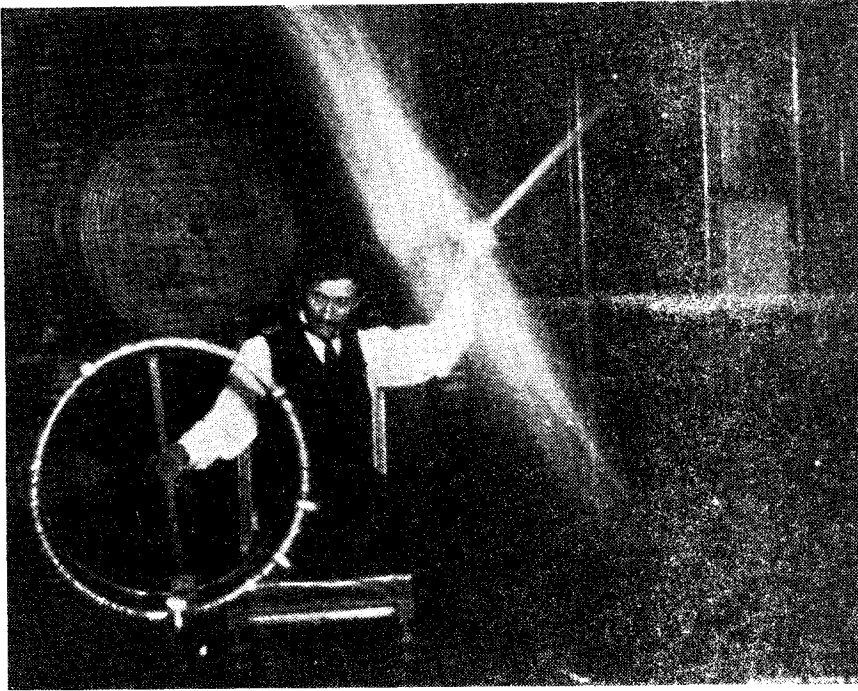
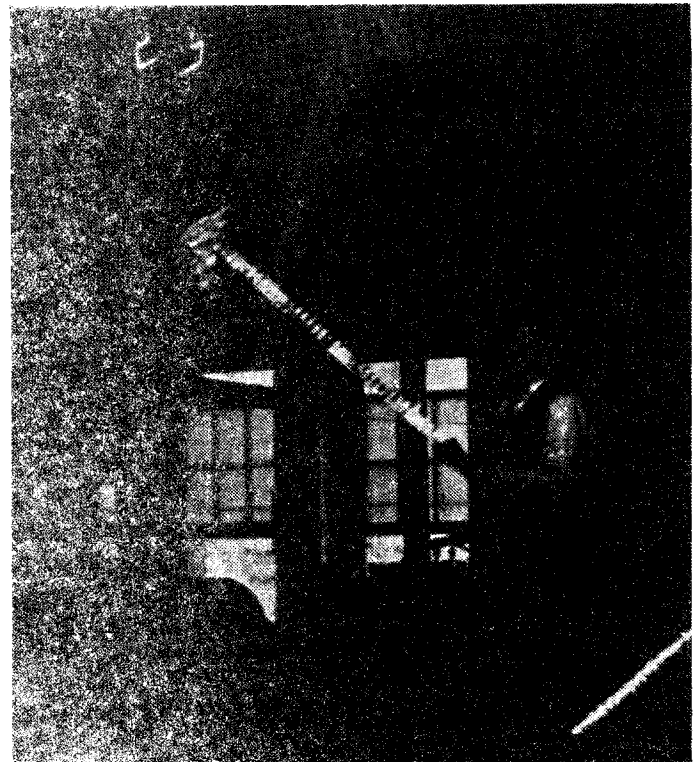

FIG. 9 - THE OPERATOR'S BODY, IN THIS EXPERIMENT, IS CHARGED TO A HIGH POTENTIAL BY MEANS OF A COIL RESPONSIVE TO THE WAVES TRANSMITTED TO IT FROM A DISTANT OSCILLATOR, AND A LONG GLASS TUBE WAVED IN THE HAND IS LIGHTED TO GREAT BRILLIANCE BY THE ELECTRICAL CHARGES CONVEYED TO IT THROUGH THE BODY.

FIG. 10 - IN THIS EXPERIMENT THE OPERATOR'S BODY IS CHARGED TO A GREAT PRESSURE BY A DIRECT CONNECTION WITH AN OSCILLATOR - THE PHOTOGRAPH SHOWS A SHEET OF TIN OF DETERMINED SIZE, HELD IN HAND - THE OPERATOR IS ON THE TOP OF A STATIONARY ELECTRICAL WAVE, AND THE BAR AND SHEET ARE BOTH ILLUMINATED BY THE VIOLENTLY AGITATED AIR SURROUNDING THEM - ONE OF THE VACUUM TUBES GLOWS BRIGHTLY, BEING AFFECTED BY THE VIBRATIONS TRANSMITTED TO IT FROM THE OPERATOR'S BODY.



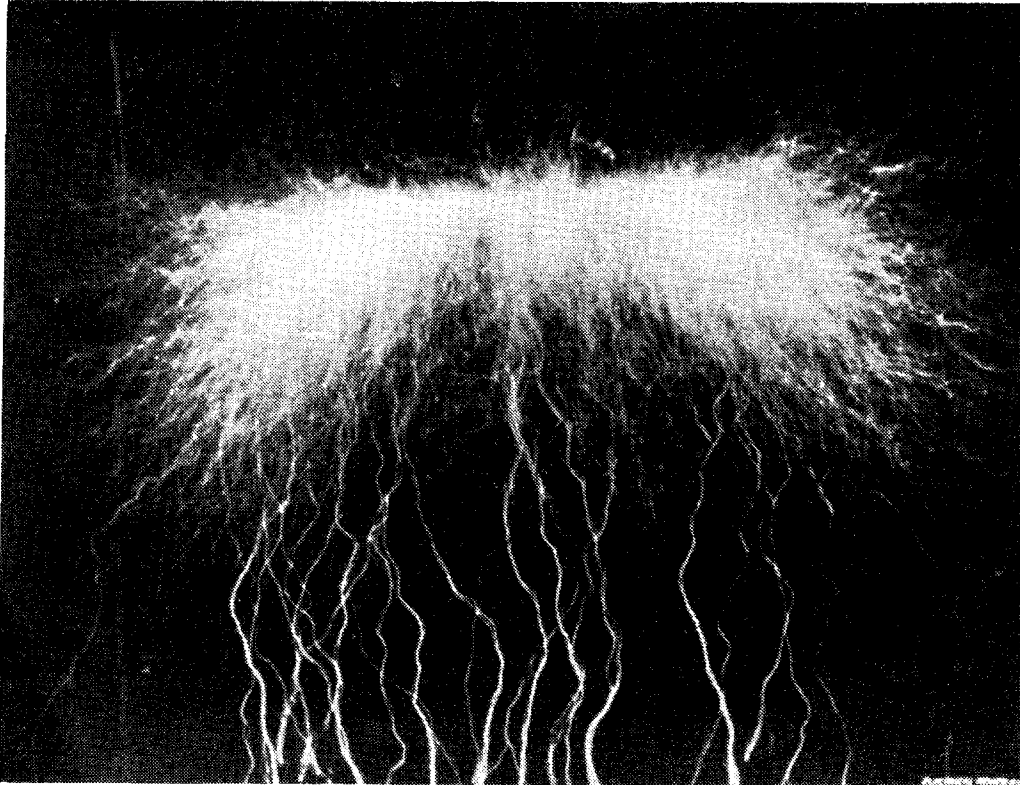

FIG. 11 - PHOTOGRAPH OF AN ACTIVE TERMINAL OF AN IMPROVED OSCILLATOR, USED IN TESLA'S EXPERIMENTS FOR TRANSMITTING ELECTRICAL ENERGY TO GREAT DISTANCES WITHOUT WIRES - WIDTH OF ILLUMINATED SPACE IS 18 FEET- THE PRESSURE ON THE TERMINAL IS ABOUT EIGHT MILLION VOLTS.

they good for, and what do they or have they demonstrated? To them it may be said that they have shown and proved among many other things: That ordinary currents can be transformed with high economy into electrical vibrations of any pitch, which are needed in many novel arts; they have shown that electrical energy in great amounts can be efficiently and safely transmitted without the use of wires to any point of the globe, however distant; they have furnished proof that the movements and operation of bodies and machinery carried by the same can be controlled from a great distance without any tangible connection whatever and with absolute precision; they have proved the practicability of a system of signaling without wires, not with the imperfect appliances as before attempted, which can not be tuned and are rendered useless by the play of a small induction coil, but by means of apparatus producing powerful oscillations and circuits in exact synchronism, with which it is impossible to interfere; they have shown that atmospheric nitrogen can be readily combined and valuable products manufactured, merely by the application of cheap water power, and that light, diffusive like that of the sun, can be produced with an economy greater than obtainable in the usual ways and with lamps that never consume.

N. Tesla.

New York, March 26, 1899

New York Sun
Jan. 30, 1901

TESLA'S NEW DISCOVERY

Capacity of Electrical Conductors is Variable.

Not Constant, and Formulas Will Have to Be Rewritten - Capacity Varies With Absolute Height Above Sea Level, Relative Height From Earth and Distance From the Sun.

Nikola Tesla announced yesterday another new discovery in electricity. This time it is a new law and by reason of it, Mr. Tesla asserts, a large part of technical literature will have to be rewritten. Ever since anything has been known about electricity, scientific men have taken for granted that the capacity of an electrical conductor is constant. When Tesla was experimenting in Colorado he found out that this capacity is not constant - but variable. Then he determined to find out the law governing this phenomenon. He did so, and all this he explained to *The Sun* yesterday. Here is what he said:

"Since many years scientific men engaged in the study of physics and electrical research have taken it for granted that certain quantities, entering continuously in their estimates and calculations, are fixed and unalterable. The exact determination of these quantities being of particular importance in electrical vibrations, which are engrossing more and more the attention of experimenters all over the world, it seems to be important to acquaint others with some of my observations, which have finally led me to the results now attracting universal attention. These observations, with which I have long been familiar, show that some of the quantities referred to are variable and that, owing to this, a large portion of the technical literature is defective. I shall endeavor to convey the knowledge of the facts I have discovered in plain language, devoid as much as possible of technicalities.

"It is well known that an electric circuit compacts itself like a spring with a weight attached to it. Such a spring vibrates at a definite rate, which is determined by two quantities, the pliability of the spring and the mass of the weight. Similarly an electric circuit vibrates, and its vibration, too, is dependent on two quantities, designated as electrostatic capacity and inductance. The capacity of the electric circuit corresponds to the pliability of the spring and the inductance to the mass of the weight.

"Exactly as mechanics and engineers have taken it for granted that the pliability of the spring remains the same, no matter how it be placed or used, so electricians and physicists have assumed that the electrostatic capacity of a conducting body, say of a metallic sphere, which is frequently used in experiments, remains a fixed and unalterable quantity, and many scientific results of the greatest importance are dependent on this assumption. Now, I have discovered that this capacity is not fixed and unalterable at all. On the contrary, it is susceptible to great changes, so that under certain conditions it may amount to many times its theoretical value, or may eventually be smaller. Inasmuch as every electrical conductor, besides possessing an inductance, has also a certain amount of capacity, owing to the variations of the latter, the inductance, too, is seemingly modified by the same causes that tend to modify the capacity. These facts I discovered some time before I gave a technical description of my system of energy transmission and telegraphy without wires, which, I believe, became first known through my Belgian and British patents.

"In this system, I then explained, that, in estimating the wave-length of the electrical vibration in the transmitting and receiving circuits, due regard must be had to the velocity with which the vibration is propagated through each of the circuits, this velocity being given by the product of the wave-length and the number of vibrations per second. The rate of vibration being, however, as before stated, dependent on the capacity and inductance in each case, I obtained discordant values.

Continuing the investigation of this astonishing phenomenon I observed that the capacity varied with the elevation of the conducting surface above the ground, and I soon ascertained the law of this variation. The capacity increased as the conducting surface was elevated, in open space, from one-half to three-quarters of 1 per cent per foot of elevation. In buildings, however, or near large structures, this increase often amounted to 50 per cent per foot of elevation, and this alone will show to what extent many of the scientific experiments recorded in technical literature are erroneous. In determining the length of the coils or conductors such as I employ in my system of wireless telegraphy, for instance, the rule which I have given is, in view of the above, important to observe.

"Far more interesting, however, for men of science is the fact I observed later, that the capacity undergoes an annual variation with a maximum in summer, and a minimum in winter. In Colorado, where I continued with improved methods of investigations begun in New York, and where I found the rate of increase slightly greater, I furthermore observed that there was a diurnal variation with a maximum during the night. Further, I found that sunlight causes a slight increase in capacity. The moon also produces an effect, but I do not attribute it to its light.

"The importance of these observations will be better appreciated when it is stated that owing to these changes of a quantity supposed to be constant an electrical circuit does not vibrate at a uniform rate, but its rate is modified in accordance with the modifications of the capacity. Thus a circuit vibrates a little slower at an elevation than when at a lower level. An oscillating system, as used in telegraphy without wires, vibrates a little quicker when the ship gets into the harbor than when on open sea. Such a circuit oscillates quicker in the winter than in the summer, though it be at the same temperature, and a trifle quicker at night than in daytime, particularly if the sun is shining.

"Taking together the results of my investigations I find that this variation of the capacity and consequently of the vibration period is evidently dependent, first, on the absolute height above sea level, though in a smaller degree; second, on the relative height of the conducting surface or capacity with respect to the bodies surrounding it; third, on the distance of the earth from the sun, and fourth, on the relative change of the circuit with respect to the sun, caused by the diurnal rotation of the earth. These facts may be of particular interest to meteorologists and astronomers, inasmuch as practical methods of inquiry may result from these observations, which may be useful in their respective fields. It is probable that we shall perfect instruments for indicating the altitude of a place by means of a circuit, properly constructed and arranged, and I have thought of a number of other uses to which this principle may be put.

"It was in the course of investigations of this kind in Colorado that I first noted certain variations in electrical systems arranged in peculiar ways. These variations I first discovered by calculating over the results I had previously noted, and it was only subsequently that I actually perceived them. It will thus be clear that some who have ventured to attribute the phenomena I have observed to ordinary atmospheric disturbances have made a hasty conclusion."

Scientific American
Feb. 2, 1901, p. 67.

TESLA'S WIRELESS LIGHT.

Nikola Tesla has given to *The New York Sun* an authorized statement concerning his new experiments on the production of light without the aid of wires. Mr. Tesla says:

"This light is the result of continuous efforts since my early experimental demonstrations before scientific societies here and abroad. In order to make it suitable for commercial use, I had to overcome great difficulties. One of these was to produce from ordinary currents of supply electrical oscillations of enormous rapidity in a simple and economical manner. This, I am glad to say, I have now accomplished, and the results show that with this new form of light a higher economy is practicable than with the present illuminants. The light offers, besides, many specific advantages, not the least of which is found in its hygienic properties. It is, I believe, the closest approach to daylight which has yet been reached from any artificial source.

"The lamps are glass tubes which may be bent in any ornamental way. I most generally use a rectangular spiral, containing about twenty to twenty-five feet of tubing making some twelve to fourteen convolutions. The total illuminating surface of a lamp is from 300 to 400 square inches. The ends of the spiral tube are covered with a metallic coating, and provided with hooks for hanging the lamp on the terminals of the source of oscillations. The tube contains gases rarefied to a certain degree, determined in the course of long experimentation as being conducive to the best results.

"The process of light production is, according to my views, as follows: The street current is passed through a machine which is an electrical oscillator of peculiar construction and transforms the supply current, be it direct or alternating, into electrical oscillations of very high frequency. These oscillations, coming to the metallically-coated ends of the glass tube, produce in the interior corresponding electrical oscillations, which set the molecules and atoms of the inclosed rarefied gases into violent commotion, causing them to vibrate at enormous rates and emit those radiations which we know as light. The gases are not rendered incandescent in the ordinary sense, for if it were so, they would be hot, like an incandescent filament. As a matter of fact, there is very little heat noticeable, which speaks well for the economy of the light, since all heat would be loss.

"This high economy results chiefly from three causes: First, from the high rate of the electrical oscillations; second, from the fact that the entire light-giving body, being a highly attenuated gas, is exposed and can throw out its radiations unimpeded, and, third, because of the smallness of the particles composing the light-giving body, in consequence of which they can be quickly thrown into a high rate of vibration, so that comparatively little energy is lost in the lower or heat vibrations. An important practical advantage is that the lamps need not be renewed like the ordinary ones, as there is nothing in them to consume. Some of these lamps I have had for years, and they are now in just as good a condition as they ever were. The illuminating power of each of these lamps is, measured by the photometric method, about fifty candle power, but I can make them of any power desired, up to that of several arc lights. It is a remarkable feature of the light that during the day it can scarcely be seen, whereas at night the whole room is

(Reprinted with permission. Copyright © 1901 by Scientific American. All rights reserved.)

brilliantly illuminated. When the eye becomes used to the light of these tubes, an ordinary incandescent lamp or gas burner produces a violent pain in the eye when it is turned on, showing in a striking manner to what a degree these concentrated sources of light which we now use are detrimental to the eye.

"I have found that in almost all its actions the light produces the same effects as sunlight, and this makes me hopeful that its introduction into dwellings will have the effect of improving, in a measure now impossible to estimate, the hygienic conditions. Since sunlight is a very powerful curative agent, and since this light makes it possible to have sunlight, so to speak, of any desired intensity, day and night in our homes, it stands to reason that the development of germs will be checked and many diseases, as consumption, for instance, successfully combated by continually exposing the patients to the rays of these lamps. I have ascertained unmistakably that the light produces a soothing action on the nerves, which I attribute to the effect which it has upon the retina of the eye. It also improves vision just exactly as the sunlight, and it ozonizes slightly the atmosphere. These effects can be regulated at will. For instance, in hospitals, where such a light is of paramount importance, lamps may be designed which will produce just that quality of ozone which the physician may desire for the purification of the atmosphere, or if necessary, the ozone production can be stopped altogether.

"The lamps are very cheap to manufacture, and by the fact that they need not be exchanged like ordinary lamps or burners they are rendered still less expensive. The chief consideration is, of course, in commercial introduction, the energy consumption. While I am not yet prepared to give exact figures, I can say that, given a certain quantity of electrical energy from the mains, I can produce more light than can be produced by the ordinary methods. In introducing this system of lighting my transformer, or oscillator, will be usually located at some convenient place in the basement, and from there the transformed currents will be led as usual through the building. The lamps can be run with one wire alone, as I have shown in my early demonstrations, and in some cases I can dispense entirely with the wires. I hope that ultimately we shall get to this ideal form of illumination, and that we shall have in our rooms lamps which will be set aglow no matter where they are placed, just as an object is heated by heat rays emanating from a stove. The lamps will then be handled like kerosene lamps, with this difference, however, that the energy will be conveyed through space. The ultimate perfection of apparatus for the production of electrical oscillations will probably bring us to this great realization, and then we shall finally have the light without heat or 'cold' light. I have no difficulty now to illuminate the room with such wireless lamps, but a number of improvements must be made yet before it can be generally introduced."

Collier's Weekly
Feb. 9, 1901, pp. 4-5.

TALKING WITH PLANETS - by Nikola Tesla

Editor's Note. - Mr. Nikola Tesla has accomplished some marvelous results in electrical discoveries. Now, with the dawn of the new century, he announces an achievement that will amaze the entire universe, and which eclipses the wildest dream of the most visionary scientist. He has received communication, he asserts, from out the great void of space; a call from inhabitants of Mars, or Venus, or some other sister planet! And, furthermore, noted scientists like Sir Norman Lockyer are disposed to agree with Mr. Tesla in his startling deductions.

Mr. Tesla has not only discovered many important principles, but most of his inventions are in practical use; notably in the harnessing of the Titanic forces of Niagara Falls, and the discovery of a new light by means of a vacuum tube. He has, he declares, solved the problem of telegraphing without wires or artificial conductors of any sort, using the earth as his medium. By means of this principle he expects to be able to send messages under the ocean, and to any distance on the earth's surface. Interplanetary communication has interested him for years, and he sees no reason why we should not soon be within talking distance of Mars or of all worlds in the solar system that may be tenanted by intelligent beings.

At the request of COLLIER'S WEEKLY Mr. Tesla present herewith a frank statement of what he expects to accomplish and how he hopes to establish communication with the planets.

The idea of communicating with the inhabitants of other worlds is an old one. But for ages it has been regarded merely as a poet's dream, forever unrealizable. And yet, with the invention and perfection of the telescope and the ever-widening knowledge of the heavens, its hold upon our imagination has been increased, and the scientific achievements during the latter part of the nineteenth century, together with the development of the tendency toward the nature ideal of Goethe, have intensified it to such a degree that it seems as if it were destined to become the dominating idea of the century that has just begun. The desire to know something of our neighbors in the immense depths of space does not spring from idle curiosity nor from thirst for knowledge, but from a deeper cause, and it is a feeling firmly rooted in the heart of every human being capable of thinking at all.

Whence, then, does it come? Who knows? Who can assign limits to the subtlety of nature's influences? Perhaps, if we could clearly perceive all the intricate mechanism of the glorious spectacle that is continually unfolding before us, and could, also, trace this desire to its distant origin, we might find it in the sorrowful vibrations of the earth which began when it parted from its celestial parent.

But in this age of reason it is not astonishing to find persons who scoff at the very thought of effecting communication with a planet. First of all, the argument is made that there is only a small probability of other planets being inhabited at all. This argument has never appealed to me. In the solar system, there seem to be only two planets - Venus and Mars - capable of sustaining life such as ours; but this does not mean that there might not be on all of them some other forms of life. Chemical processes may be maintained without the aid of oxygen, and it is still a question whether chemical processes are absolutely necessary for the sustenance of organized beings. My idea is that the development of life must lead to forms of existence that will be possible without nourishment and which will not be shackled by consequent limitations. Why should a living being not be able to obtain all the energy it needs for the performance of its life-functions from the environment, instead of through consumption of food, and transforming, by a complicated process, the energy of chemical combinations into life-sustaining energy?

If there were such beings on one of the planets we should know next to nothing about them. Nor is it necessary to go so far in our assumptions, for we can readily conceive that, in the same degree as the atmosphere diminishes in density, moisture disappears and the planet freezes up, organic life might also undergo corresponding modifications, leading finally to forms which, according to our present ideas of life, are impossible. I will readily admit, of course, that if there should be a sudden catastrophe of any kind all life process might be arrested; but if the changes, no matter how great, should be gradual, and occupied ages, so that the ultimate results could be intelligently foreseen, I cannot but think that reasoning beings would still find means of existence. They would adapt themselves to their constantly changing environment. So I think it quite possible that in a frozen planet, such as our moon is supposed to be, intelligent beings may still dwell, in its interior, if not on its surface.

SIGNALLING AT 1,000,000 MILES!

Then it is contended that it is beyond human power and ingenuity to convey signals to the almost inconceivable distances of fifty million or one hundred million miles. This might have been a valid argument formerly. It is not so now. Most of those who are enthusiastic upon the subject of interplanetary communication have reposed their faith in the light-ray as the best possible medium of such communication. True, waves of light, owing to their immense rapidity of succession, can penetrate space more readily than waves less rapid, but a simple consideration will show that by their means an exchange of signals between this earth and its companions in the solar system is, at least now, impossible. By way of illustration, let us suppose that a square mile of the earth's surface - the smallest area that might possibly be within reach of the best telescopic vision of other world's - were covered with incandescent lamps, packed closely together so as to form, when illuminated, a continuous sheet of light. It would require not less than one hundred million horse power to light this area of lamps, and this is many times the amount of motive power now in the service of man throughout the world.

But with the novel means, proposed by myself, I can readily demonstrate that, with an expenditure not exceeding two thousand horse-power, signals can be transmitted to a planet such as Mars with as much exactness and certitude as we now send messages by wire from New York to Philadelphia. These means are the result of long continued experiment and gradual improvement.

Some ten years ago, I recognized the fact that to convey electric currents to a distance it was not at all necessary to employ a return wire, but that any amount of energy might be transmitted by using a single wire. I illustrated this principle by numerous experiments, which, at that time, excited considerable attention among scientific men.

This being practically demonstrated, my next step was to use the earth itself as the medium for conducting the currents, thus dispensing with wires and all other artificial conductors. So I was led to the development of a system of energy transmission and of telegraphy without the use of wires, which I described in 1893. The difficulties I encountered at first in the transmission of currents through the earth were very great. At that time I had at hand only ordinary apparatus, which I found to be ineffective, and I concentrated my attention immediately upon perfecting machines for this special purpose. This work consumed a number of years, but I finally vanquished all difficulties and succeeded in producing a machine which, to explain its operation in plain language, resembled a pump in its action, drawing electricity from the earth and driving it back into the same at an enormous rate, thus creating ripples or disturbances which, spreading through the earth as through a wire, could be detected at great distances by carefully attuned receiving circuits. In this manner I was able to transmit to a distance, not only feeble effects

for purposes of signalling, but considerable amounts of energy, and later discoveries I made convince me that I shall ultimately succeed in conveying power without wires, for industrial purposes, with high economy, and to any distance, however great.

EXPERIMENTS IN COLORADO

To develop these inventions further, I went to Colorado in 1899, where I continued my investigations along these and other lines, one of which in particular I now consider of even greater importance than the transmission of power without wires. I constructed a laboratory in the neighborhood of Pike's Peak. The conditions in the pure air of the Colorado mountains proved extremely favorable for my experiments, and the results were most gratifying to me. I found that I could not only accomplish more work, physically and mentally, than I could in New York, but that electrical effects and changes were more readily and distinctly perceived. A few years ago it was virtually impossible to produce electrical sparks twenty or thirty feet long; but I produced some more than one hundred feet in length, and this without difficulty. The rates of electrical movement involved in strong induction apparatus had measured but a few hundred horse-power, and I produced electrical movements of rates of one hundred and ten thousand horse-power. Prior to this, only insignificant electrical pressures were obtained, while I have reached fifty million volts.

The accompanying illustrations, with their descriptive titles, taken from an article I wrote for the "Century Magazine," may serve to convey an idea of the results I obtained in the directions indicated.

Many persons in my own profession have wondered at them and have asked what I am trying to do. But the time is not far away now when the practical results of my labors will be placed before the world and their influence felt everywhere. One of the immediate consequences will be the transmission of messages without wires, over sea or land, to an immense distance. I have already demonstrated, by crucial tests, the practicability of signalling by my system from one to any other point of the globe, no matter how remote, and I shall soon convert the disbelievers.

I have every reason for congratulating myself that throughout these experiments, many of which were exceedingly delicate and hazardous, neither myself nor any of my assistants received an injury. When working with these powerful electrical oscillations the most extraordinary phenomena take place at times. Owing to some interference of the oscillations, veritable balls of fire are apt to leap out to a great distance, and if any one were within or near their path, he would be instantly destroyed. A machine such as I have used could easily kill, in an instant, three hundred thousand persons. I observed that the strain upon my assistants was telling, and some of them could not endure the extreme tension of the nerves. But these perils are now entirely overcome, and the operation of such apparatus, however powerful, involves no risk whatever.

As I was improving my machines for the production of intense electrical actions, I was also perfecting the means for observing feeble effects. One of the most interesting results, and also one of great practical importance, was the development of certain contrivances for indicating at a distance of many hundred miles an approaching storm, its direction, speed and distance travelled. These appliances are likely to be valuable in future meteorological observations and surveying, and will lend themselves particularly to many naval uses.

It was in carrying on this work that for the first time I discovered those mysterious effects which have elicited such unusual interest. I had perfected the apparatus referred to so far that from my laboratory in the Colorado mountains I could feel the pulse of the globe, as it were, noting every electrical change that occurred within a radius of eleven hundred miles.

TERRIFIED BY SUCCESS

I can never forget the first sensations I experienced when it dawned upon me that I had observed something possibly of incalculable consequences to mankind. I felt as though I were present at the birth of a new knowledge or the revelation of a great truth. Even now, at times, I can vividly recall the incident, and see my apparatus as though it were actually before me. My first observations positively terrified me, as there was present in them something mysterious, not to say supernatural, and I was alone in my laboratory at night; but at that time the idea of these disturbances being intelligently controlled signals did not yet present itself to me.

The changes I noted were taking place periodically, and with such a clear suggestion of number and order that they were not traceable to any cause then known to me. I was familiar, of course, with such electrical disturbances as are produced by the sun, Aurora Borealis and earth currents, and I was as sure as I could be of any fact that these variations were due to none of these causes. The nature of my experiments precluded the possibility of the changes being produced by atmospheric disturbances, as has been rashly asserted by some. It was some time afterward when the thought flashed upon my mind that the disturbances I had observed might be due to an intelligent control. Although I could not decipher their meaning, it was impossible for me to think of them as having been entirely accidental. The feeling is constantly growing on me that I had been the first to hear the greeting of one planet to another. A purpose was behind these electrical signals; and it was with this conviction that I announced to the Red Cross Society, when it asked me to indicate one of the great possible achievements of the next hundred years, that it would probably be the confirmation and interpretation of this planetary challenge to us.

Since my return to New York more urgent work has consumed all my attention; but I have never ceased to think of those experiences and of the observations made in Colorado. I am constantly endeavoring to improve and perfect my apparatus, and just as soon as practicable I shall again take up the thread of my investigations at the point where I have been forced to lay it down for a time.

COMMUNICATING WITH THE MARTIANS

At the present stage of progress, there would be no insurmountable obstacle in constructing a machine capable of conveying a message to Mars, nor would there be any great difficulty in recording signals transmitted to us by the inhabitants of that planet, if they be skilled electricians. Communication once established, even in the simplest way, as by a mere interchange of numbers, the progress toward more intelligible communication would be rapid. Absolute certitude as to the receipt and interchange of messages would be reached as soon as we could respond with the number "four," say, in reply to the signal "one, two, three." The Martians, or the inhabitants of whatever planet had signalled to us, would understand at once that we had caught their message across the gulf of space and had sent back a response. To convey a knowledge of form by such means is, while very difficult, not impossible, and I have already found a way of doing it.

What a tremendous stir this would make in the world! How soon will it come? For that it will some time be accomplished must be clear to every thoughtful being.

Something, at least, science has gained. But I hope that it will also be demonstrated soon that in my experiments in the West I was not merely beholding a vision, but had caught sight of a great and profound truth.

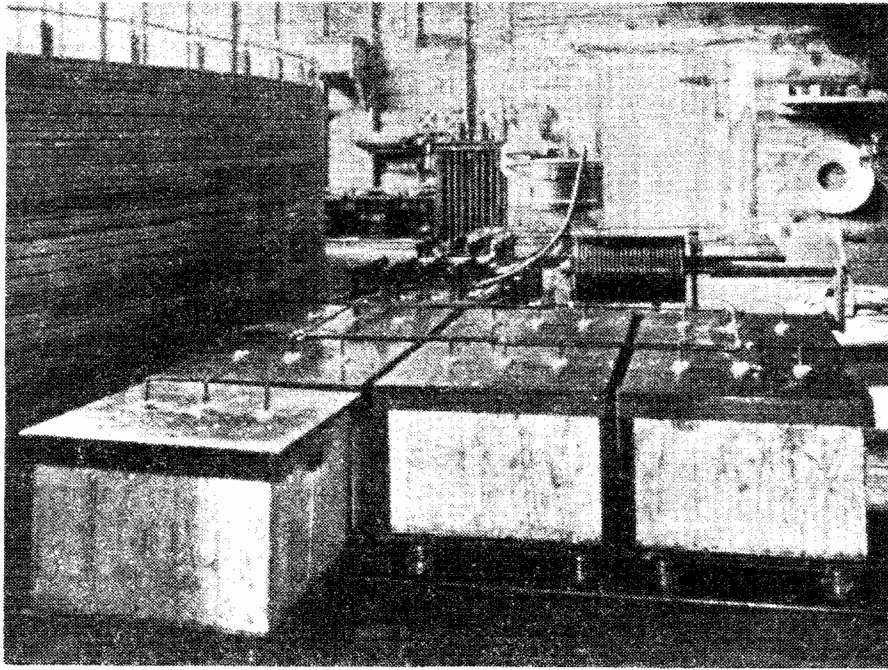

VIEW OF THE ESSENTIAL PARTS OF THE ELECTRICAL
OSCILLATOR USED IN THE EXPERIMENTS DESCRIBED.

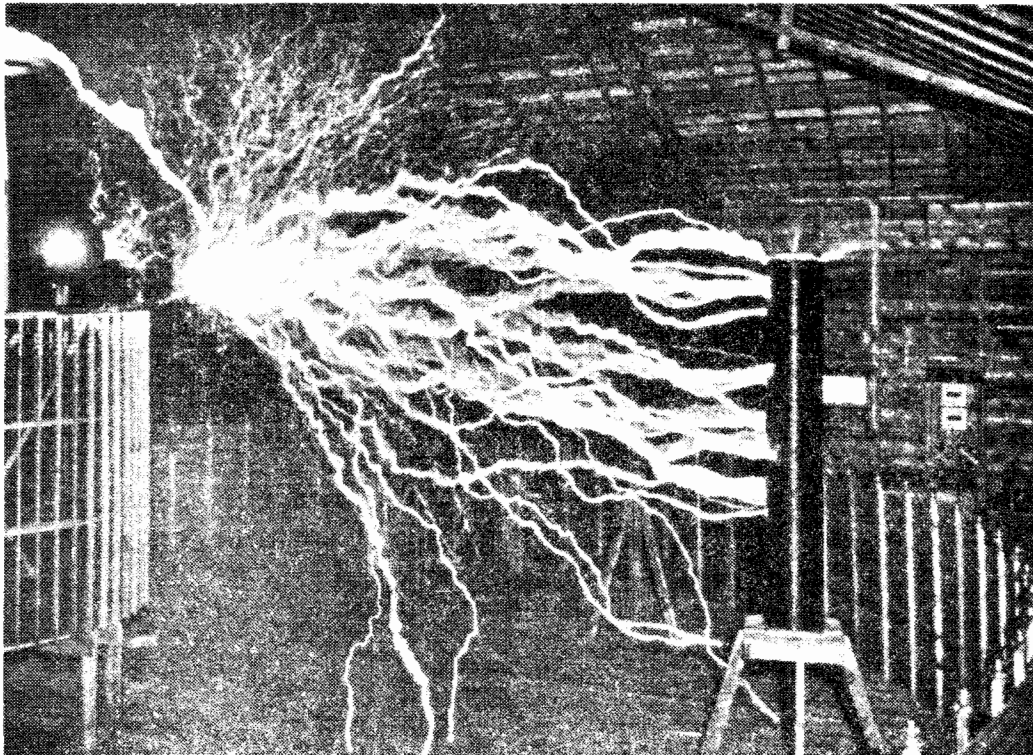

EXPERIMENT TO ILLUSTRATE THE CAPACITY OF THE OSCILLATOR
FOR PRODUCING ELECTRICAL EXPLOSIONS OF GREAT POWER.

Philadelphia - North American

May 18, 1902

STARTLING PREDICTION OF THE WORLD'S GREATEST LIVING SCIENTIST IN AN ARTICLE
WRITTEN FOR THE SUNDAY NORTH AMERICAN

Lord Kelvin's article containing the astonishing prophecy that windmills will furnish the future power of the world was written expressly for the Sunday North American during his recent visit to the United States. It is the only article that came from his pen while he was in America. Emanating from a less famous source the prediction that one day the earth will return to its most primitive motive power would be received with little less than ridicule. In view of the fact that Lord Kelvin is beyond question the greatest scientific authority, as is shown by the reverence with which he was received by American savants, his opinion in this matter is of the utmost importance to the world at large.

In discussing the subject with a reporter for the Sunday North American, Lord Kelvin asserted that from the present outlook the windmill will be the only source of motive power to which man will be able to turn once the supply of coal is exhausted. Storehouses of power, such as Niagara Falls, he said, appear, upon their face, to be enormous, but when the tremendous amount of energy required to move the wheels of the earth's energy is considered, they sink into insignificance. Once the coal fields are stripped of their precious contents, he stated, efforts will doubtless be made to raise at least a partial supply of fuel upon the farms of the land. This is not so unreasonable as at first it seems. The farmers in Iowa and Nebraska, where coal is scarce and very expensive, are even now burning their excess of corn as fuel. The supply from this source, will, as Lord Kelvin points out, necessarily be very limited, as years go by and the population of the world increases. The supply of air, however, is inexhaustible and Lord Kelvin believes man will be obliged to have recourse to it as a motive power, just as he did hundreds of years ago.

Commenting on the motive power of the future, Nikola Tesla, the electrical scientist, agrees with Lord Kelvin that the world must one day fall back upon the force of the wind. Thomas A. Edison, who in addition to being the world's greatest electrician is a man of varied achievements, admits that one day the fuel supply will be exhausted. This day he believes will be exceedingly remote, estimating that the South American forests alone could provide fuel, in wood, for fifty thousand years. When the last bit of fuel has been consumed, the wind may be utilized in generating electricity which will turn a good portion of the world's machinery. It is suggested by Professor Langley, in speaking of Lord Kelvin's prophecy, that the sun may one day share with the wind in furnishing power, if indeed it does not do all the work. Admiral Bradford, who has been busy for the past few years locating sites for United States coaling stations at the four corners of the earth, takes the most optimistic view of all. He believes that when the coal supply is exhausted some other means of furnishing motive power equally good will be found to take its place, and that the world will not be seriously affected.

WINDMILLS MUST BE THE FUTURE SOURCE OF POWER - by Lord Kelvin

(The only article written by Lord Kelvin during his recent visit to the United States)

To predict that the world's industrial progress will one day be halted and then rolled back in primitive methods is not a very daring prophecy when the conditions are studied closely.

Coal is king of the industrial world. The king's reign is limited. Sooner or later, it has been estimated that the world's supply of coal will have been exhausted. The commission appointed to inquire into the all-important matter in Great

Britain has even said that a few hundred years at the outside will see the last basket of coal taken from the mines of England. In other quarters the supply is rapidly diminishing.

The enormous amount of coal required to run our great ocean steamships, our leviathans of the deep, and the innumerable factories of our cities is making such inroads upon the available store that nature cannot forever supply the demand. When all the coal of the earth is used, what then?

Perplexed humanity confronted with the possibility of its industrial machinery being stopped for want of power, will be forced to turn from earth to air. In the world there is to be found a force that has stood man in good stead from time immemorial. Long before the days of the steam engine or the ocean liners, ships were wafted from shore to shore by means of the force that lurks in the air. The time will come, unless man's ingenuity devises some means of replacing the exhausted coal supply with a fuel that will be equally efficacious - when the swift steaming greyhounds of the oceans will be dry-docked and their vitals torn out. Then the lightened ships will be fitted with the masts and sails of the old sailing days, and once more the seas will be dotted with vessels propelled by the method that is at present in decline. The day upon which the last shovelful of coal is taken from the bowels of the earth will mark the passing of the magnificent battleship, the swift cruiser and the torpedo boat. The navies of the nations will perish in a day for want of life-giving fire in the furnace rooms. In their place will arise white-winged fleets depending alone on their sailing power, as in the days of Nelson; the question of which ocean liner can cut down time of the passage from New York to Liverpool will no longer interest voyagers, for the trip will depend, as of old, on the favorable winds and the sailing capacity of the ship.

On land the effect of the exhaustion of the coal supply will be even more marked than on sea. Every building could be supplied with its own windmill, to use the motive power that wanders where it listeth on its roof top to turn wheels that will lift its elevators, generate electricity for its machinery, pump its water supply and do all that coal now makes possible in the machine room; sails on our factories, sails on our mills and in our shipyards to catch the slightest breath that blows and turn it into a means of moving the wheels of progress; wind power utilized everywhere as the servant of man, free for every one, working silently as a great force while the world sleeps. Possibly the exhaustion of the coal supply of the earth may turn out to be something of a blessing when it is considered how difficult and dangerous it is to wrest from the ground the hidden resources of nature for use as fuel, and how natural and easy it is to make the power of wind do the work now done by coal.

Then, in the great land changes of the coalless age I see vast fields of vegetation planted especially to serve as fuel. Each agriculturist will have his own reservation where the family fuel will be grown; a new industry will be born - the cultivation of fuel.

Water power will be largely useful, but the power to be derived from this source is not very great. Niagara is a vast force to look at, but measured in the horsepower it is not so tremendous. The tides cannot furnish any power worth speaking of; firewood must do much more.

ACHIEVEMENTS THAT HAVE MADE LORD KELVIN FAMOUS

He Established the Doctrine of the Conservation of Energy.
His Siphon Recorder Made Transatlantic Telegraphy Feasible-
Business Man and Able Politician

It is not exaggeration to say that no living scientist ranks higher than Lord Kelvin. His fame is world-wide. The savants of all countries recognize in him the

greatest of physicists, and the rare combinations of an abstruse thinker and a practical inventor.

Merely to mention a few of the directions in which he has achieved success is to show the extraordinary activity that has marked his career.

His fame as an electrician almost equals his eminence as a physicist. He is an unequalled mathematician, the inventor of a hundred valuable devices which are in daily use, a great teacher, an expounder of popular science, and a clever and successful politician.

What he has done in any one of these lines would suffice to make a proud reputation, and in addition he has found time to be a keen business man and to build up a considerable fortune.

And all this is the achievement of a man who started poor and had his own way to make practically without assistance.

Kelvin, then plain William Thomson, first became noted for the part he played in the invention and installation of the Atlantic cable.

This was in 1857. The greatest obstacle which had to be overcome before the system could be established was a certain sluggishness in the flow of the current which had the effect of making the message almost inaudible. Thomson promptly remedied this defect, and then set himself to the discovery of an instrument for taking down cable messages.

The result was the "siphon recorder", which is still in use throughout the world in all ocean telegraphy. With it as many as 130 words per minute have been sent, where two or three were formerly the rule.

Along the same line Kelvin also invented numerous instruments for measuring both strong and feeble currents. For his work in connection with the cable Thomson was knighted. Twenty-five years later, in 1892, he was elevated to the peerage as Lord Kelvin.

Even before his great success with the cable the young inventor had been recognized as a scientist of exceptional attainments. It is a fact, indeed, that he began doing great things when little more than a boy.

His chair as professor of natural philosophy at Glasgow he won when only 22 years of age. The attention of English scholars had been drawn to him at that time because of his mathematical prowess - he won ten prizes and wrote many important papers while at Cambridge.

For fifty-three years he held his chair at Glasgow, and the passing of the half century was signaled by a celebration in which the scientists of practically the whole world took part. It was a great spontaneous demonstration entirely without precedent or parallel.

The distinctive feature of Lord Kelvin's activities, the keynote to his career, so to speak, is his power of combining the abstract with the practical. Although a profound thinker and scholar, to whom the most advanced lines of human research are as simple as the alphabet to the ordinary layman, he has been the inventor of a legion of the little things that men need in their everyday lives. Not only has he dealt in theory, but he has done things.

His various measuring and testing devices have kept a firm of instrument makers in Glasgow busy for years.

Among these, probably the best known is his magnetic compass for the use of mariners. This was such a radical improvement on any existing instrument that it displaces the others, and still remains a factor of incalculable value in securing the safety of ocean travel.

Another important invention much used on ships is a deep-sea sounding apparatus, which permits what previously had never even been dreamed of, the taking of soundings in 100 fathoms from a ship running 16 knots.

Many of Lord Kelvin's researches have dealt with the doctrine of the conservation of energy. He was, indeed, one of the six or eight men, who, living in different countries and working in entire independence of each other, simultaneously established this important theory. Another subject which he has made a specialty, is the age of the earth, and his controversies with the extravagant claims of the geologists are renowned.

The present theory of the ether, the light-bearing, electricity-carrying something which fills all space, has been in large part his creation, and his famous idea that what we call matter is merely vortices or whirlpools in this ether may be regarded as one of the most far-reaching speculations in modern physics. The mechanical principle by which we obtain liquid air - that a compressed gas expanding freely, without doing work, cools slightly more than the theory demands - is a discovery Kelvin made in conjunction with his friend Joule.

So great an authority has Lord Kelvin become on all matters dealing with either speculative or practical science that in England he is called upon to pass on the practicability of almost every important scientific proposition that comes up for discussion.

His laboratory contains the best equipment in the world for making tests. The first storage batteries imported into England from France were sent to him for a verdict. When American capitalists conceived the plan of utilizing the power of Niagara Falls for commercial purposes and of transmitting it for distances, it was Lord Kelvin whom they placed at the head of the committee of experts which passed on the original plans.

Lord Kelvin's achievements as physicist, electrician and inventor would have made at least three eminent reputations. His marvelous works have not only been recognized by Great Britain, but nearly all the nations of Europe have showered their honors upon him. He is a member of the Prussian Order pour le Merite, grand officer of the Legion of Honor of France, commander of the Order of King Leopold of Belgium, order of the first class of Sacred Treasure of Japan, foreign associate of the Berlin Academy of Science, president of the Royal Society of England and many others. Fifteen universities have conferred on him the honor of their degrees.

EDISON, TESLA, ADMIRAL BRADFORD AND PROF. LANGLEY DISCUSS FROM THEIR POINTS OF VIEW HIS AMAZING PROPHECY

TESLA THINKS WIND POWER SHOULD BE USED MORE NOW - by Nikola Tesla

The power of the wind has been overlooked. Some day it will be forcibly brought to the position it deserves through the need of a substitute for the present method of generating power. Given a good breeze, I have estimated that there is as much as half a horse-power to every square foot of area exposed. Imagine what energy is left unused with all this force at hand.

The contrivance that has been at the disposal of mankind from all time, the windmill, is now seen in the rural districts only. The popular mind cannot grasp the power there is in the wind. Many a deluded inventor has spent years of his life in endeavoring to harness the tides, and some have even proposed to compress air by tide or wave power for supplying energy, never understanding the signs of the old windmill on the hill as it sorrowfully waves its arms about and bids them stop.

The fact is that the wave or tide motor would have but small chance of competing commercially with the windmill, which is by far the better machine, allowing a much greater amount of energy to be obtained in a simpler way.

Wind power has been in all times of inestimable value to man, if for nothing else than for enabling him to cross the seas, and it is even now a very important factor in transportation. But there are limitations in this simple method of utilizing the sun's energy. The machines are large for a given output and the power is intermittent, thus necessitating a storage of energy and increasing the cost of the plant. But there is no question as to its usefulness as a substitute for the energy derived from fuel, and the fact that this power is literally as free as air makes it a wonderful factor in the future of the world of industry.

Apart from the views expressed by Lord Kelvin regarding the future, when the coal supply shall have been exhausted, there is need of more attention being paid to it in the present day.

The man who cannot afford to have a furnace in his house may have a windmill on the roof. In this labor-saving age it is astonishing that farmers are the only citizens who call the wind their friend. Dwellers in cities toil up and down stairs hauling and carrying while above them is a good-natured giant who can do all this work for them if they will but force him into service. Why wait for the coal supply of the earth to be exhausted before enlisting the aid of this vast aerial force?

The power to run elevators, pump water to roof tanks, cool houses in the summer and heat them in the winter is above us, at any one's beck and call.

A little ingenuity will enable any householder to harness the wind and leave it to do the work that he has considered part of the curse of Adam.

SUN'S RAYS WILL BE HARNESSSED, SUGGESTS PROFESSOR LANGLEY - by Professor S. P. Langley, of the Smithsonian Institution.

Lord Kelvin's suggestion of the return to wind as a motive power is pregnant of suggestion.

The problem is one that must engage the scientific mind until pressure of circumstances forces a solution. But, at the same time, while I do not wish to place myself in the position of flatly contradicting so eminent a thinker and student as his Lordship, I feel that his solution of the problem is but partial at the best, and that the true substitute for coal will be found in another direction.

The power that exists in the sun's rays will, in all probability, be the force that will drive the wheels of factories and propel ships and railroads. The tremendous energy that is stored in these rays has long been known to science and several practical attempts have been made to utilize them. As I have already pointed out in my work, "The New Economy," the idea is beginning to pass into the region of the practical utility, and is the form of the latest achievement of Mr. Ericsson's ever young genius is ready for actual work on an economical scale. His new solar engine, which there is every reason to believe is more efficient than Mouchot's would probably be capable of economical use for pumping water in the desert regions of our own country. We must consider the growing demand for power in the world and the fact that its stock of coal, though vast, is strictly limited in the sense that when it is gone we can get absolutely no more. The sun has been making a little every day for millions of years - so little and for so long that it is as though time had daily dripped a single penny into the bank for our credit for untold ages, until an enormous fund had been thus slowly accumulated in our favor. We are now drawing on this fund like a prodigal who thinks his means endless, but the day will come when our check will no longer be honored, and what shall we do then?

The exhaustion of some of the coal beds is an affair of the immediate future, by comparison with the vast period of time we have been speaking of. The English coal beds, it is asserted, will be quite used up in about three hundred years more.

Three hundred years ago the sun, looking down on the England of our forefathers, saw a fair land of green woods and quiet waters, a land unvexed with noisier machinery than the spinning wheel. Because of the coal which has been dug from its soil, he sees it now soot-blackened, furrowed with railway cuttings, covered with noisy manufactories, filled with grimy operatives, while the island shakes with the throb of coal-driven engines, and its once quiet waters are churned by the wheels of steamships. Many generations of men have passed to make the England of Elizabeth into the England of King Edward, but what a brief moment this is compared with the vast lapse of ages during which the coal was being stored! What a moment in the life of the "all-beholding sun", who in a few hundred years may send his beams through rents in the ivy-grown walls of deserted factories, upon silent engines brown with rust, while the mill hand has gone to other lands, the rivers are clean again, the harbors show only white sails and England's "black country" is green once more! To America, too, such a time may come, though at a more distant date.

Future ages may see the seat of empire transferred to regions of the earth now barren and desolated under intense solar heat - countries which, for that very cause, will not improbably become the seat of mechanical and hence of political power.

Whoever finds the way to make industrially useful, the vast sun power now wasted on the deserts of North Africa or the shores of the Red Sea will effect a greater change in men's affairs than any conqueror in history has done. He will once more people those waste places with the life that swarmed there in the best days of Carthage and of old Egypt, but under another civilization, where man no longer shall worship the sun as a god, but shall have learned to make it his servant.

EDISON PUTS OFF THE EVIL DAY FOR MORE THAN 50,000 YEARS - by Thomas A. Edison

I cannot altogether agree with Lord Kelvin as to the nearness of time when the fuel supply of the world will be exhausted.

There is wood enough in the forests of South America to supply the world with fuel for 50,000 years. Wood as fuel takes up more space than coal, but it must be remembered that we are constantly economizing on the amount of fuel necessary to do a given amount of work. The quantity of fuel used to run a locomotive is being reduced as the machine is perfected and the engineers learn to make the coal box smaller without reducing the speed of the engine. By the time the coal supply is exhausted it may be possible to burn wood with equally good results.

A windmill is a big cumbersome thing and I cannot think it possible that progressive men will settle down contented to go back to this primitive method of obtaining power. I have a windmill on my own property, but I never thought it amounted to much, except for pumping water. Wind power, as every schoolboy knows, can be used for generating electricity, but the horsepower thus obtained would not be adequate to the demands of this bustling age.

Additional energy could be obtained by ships at sea from the motion of the vessel being utilized as a generative agent. While the ship moves through the water, propelled by the force of the wind on its sails, the wave power could be caught up and turned into a means of providing electricity. Then, too, seamen will probably explain that the wind that drives a ship is not the only force to be obtained from the air. There are aerial currents that can be made use of by means of appropriate appliances for catching their force.

MAN'S WIT WILL SOLVE THE PROBLEM - by Rear Admiral R. B. Bradford

Rear Admiral R. B. Bradford, chief of the Bureau of Equipment, at Washington, regards the question of the future motive power from an extremely practical standpoint.

"Lord Kelvin," he said, "is a scientist, a great scientist, but I think he is borrowing trouble. The problem that is before us now is not what the motive power will be two hundred or three hundred years from to-day. It is how best may we conserve the energy we have already stored away in coal. The supply of this article is strictly limited, and its consumption is increasing in almost arithmetical ratio.

"Unless some force is discovered to replace it, we will soon be at the end of our resources. But it is also true that unless something is discovered to take the place of coal and steam, we shall be compelled to fall back in the end upon the two great forces of nature - the sun's rays and the wind. Both of these can be utilized to generate power, but the trouble with both is that they are variable.

"Power cannot, of course, be generated from the sun's rays at night, nor on a cloudy day, and we have periods of calm, when the wind is scarcely perceptible.

"On the other hand, to say what the power of the future will be is pure speculation and prophecy. I am no seventh son of a seventh son, and do not care to go into the prophesying business. But fifty years before the discovery of the steam engine or the discovery of coal, who would have dared to predict the present mechanical development of civilization?

"Something of the same sort may occur during the next fifty years. Some ingenious man may discover a force of nature that will entirely supersede steam. But this I can say, that unless such a discovery is made, the windmills will in time throw their arms to the breeze, and the solar engines will pump our water and drive our factories."

Electrical World and Engineer
Feb. 6, 1904, p. 256.

A STRIKING TESLA MANIFESTO

We reproduce herewith in slightly reduced facsimile the first page of a four-page circular which has been issued this week by Mr. Nikola Tesla in a large square envelope bearing a large red wax seal with the initials, "N.T." At the back of the page which we reproduce is given a list of 93 patents issued in this country to Mr. Tesla. The fourth page is blank. The third page has a little vignette of Niagara Falls and is devoted to quotations from various utterances of Mr. Tesla. The first of these is from his lecture delivered in 1893 before the Franklin Institute and the National Electric Light Association, as to transmission of intelligible signals and power to any distance without the use of wires. The second quotation is from his article on the problem of increasing human energy, which appeared in the *Century Magazine* in June, 1900, dealing with virtually the same subject. The third item quotes from his patents, Nos. 645,576 and 649,621, dealing with the transmission of electrical energy in any quantity to any distance, with transmitting and receiving apparatus movable as in ships or balloons. The circular is an extremely interesting one. It is most sumptuously got up on vellum paper and altogether constitutes a manifesto worthy of the original genius issuing it. It is to be gathered from the circular that Mr. Tesla proposes to enter the field of consulting engineering, in which he already has enjoyed an extensive connection here and abroad.

Reprinted with permission. Reprinted from Feb. 6, 1904, issue of *Electrical World*.
© Copyright 1904, McGraw-Hill, Inc. All rights reserved.

PRINTED IN SACILELLI SQUARE NEW YORK CITY

Electrical oscillator activity ten million horsepower

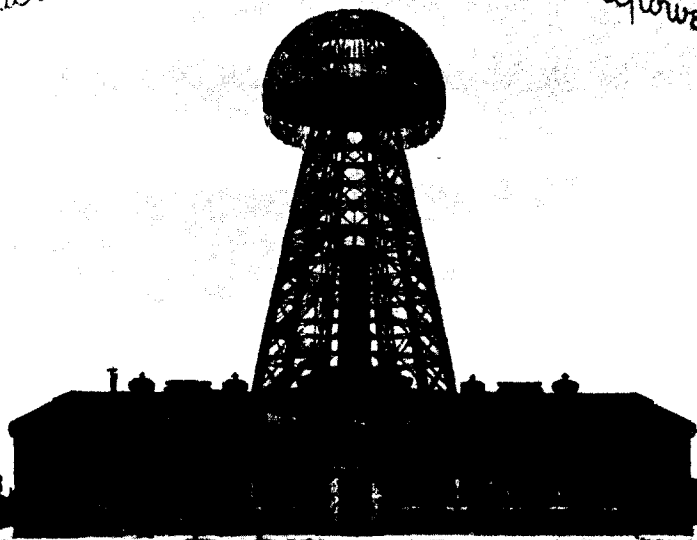
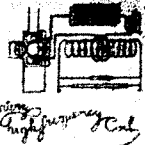
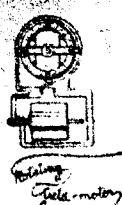

Power transmission without wires

New York, January 1, 1904

I wish to announce that in connection with the commercial introduction of my inventions I shall render professional services in the general capacity of consulting electrician and engineer.

The near future, I expect with confidence, will be a witness of revolutionary departures in the production, transformation and transmission of energy, transportation, lighting, manufacture of chemical compounds, telegraphy, telephony and other arts and industries.

In my opinion, these advances are certain to follow from the universal adoption of high-potential and high-frequency currents and novel regenerative processes of refrigeration to very low temperatures.

Much of the old apparatus will have to be improved, and much of the new developed, and I believe that while furthering my own inventions, I shall be more helpful in this evolution by placing at the disposal of others the knowledge and experience I have gained.

Special attention will be given by me to the solution of problems requiring both expert information and inventive resource—work coming within the sphere of my constant training and predilection.

I shall undertake the experimental investigation and perfection of ideas, methods and appliances, the devising of useful expedients and, in particular, the design and construction of machinery for the attainment of desired results.

Any task submitted to and accepted by me, will be carried out thoroughly and conscientiously.

Laboratory, Long Island, N. Y.
Residence, Waldorf, New York City.

Nikola Tesla

Burning atmospheric nitrogen by high frequency discharge twelve millions volts



Source from interfrequency and multiplicity of messages

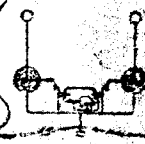
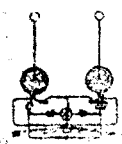
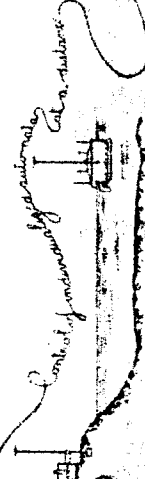

New York Sun
November 27, 1904

Letter from Nikola Tesla:

"My attention has been called to numerous comments on my letter, published in your issue of November 1, and relating to the electrical equipment of the newly opened catacomb in this city. Some of them are based on erroneous assumptions, which it is necessary for me to correct.

"When I stated that my system was adopted, I did not mean that I originated every electrical appliance in the subway. For instance, the one which that ill-fated electrician was repairing when he was killed, two days after the catacomb was ready for public use, was not invented by me. Nor was that other device on the sidetracked car, which, as will be remembered, caused the burning of two men. I also must deny any connection with that switch or contrivance which was responsible for the premature death of a man immediately afterward, as well as with that other, which cut short the life of his unfortunate successor. None of these funeral devices, I emphatically state, or any of the other which brought on collisions, delays and various troubles and were instrumental in the loss of arms and legs of several victims, are of my invention, nor do they form, in my opinion, necessary appurtenances of an intelligently planned scheme for the propulsion of cars. Referring to these contrivances, it is significant to read in some journals of the 8th inst. that a small firm failed because their bid was too low. This is indicative of keen competition and sharp cutting of prices, and does not seem in keeping with the munificence claimed for the Interborough Company.

"I merely intended to say in my letter that my system of power transmission with three-phase generators and synchronous motor converters was adopted in the subway, the same as on the elevated road. I devised it many years ago for the express purpose of meeting the varied wants of a general electrical distribution of light and power. It has been extensively introduced all over the world because of its great flexibility, and under such conditions of use has been found of great value. But the idea of employing in this great city's main artery, in a case presenting such rigid requirements, this flexible system, offering innumerable chances for breakdowns, accidents and injuries to life and property, is altogether too absurd to dignify it with any serious comment. Here only my multiphase system, with induction motors and closed coil armatures - apparatus unailing in its operation and minimizing the dangers of travel - should have been installed. Nothing, not even ignorance, will prevent its ultimate adoption; and the sooner the change is made the better it will be for all concerned. Personally, I have no financial or other interest in the matter, except that as a long resident of this city I would have been glad to see my inventions properly used to the advantage of the community. Under the circumstances I must forego this gratification.

"The consequences of the unpardonable mistake of the Interborough Company are not confined to this first subway or even to this city. We are driven to travel underground. The elevated road is the eighth wonder, as colossal and imposing in the feature of public forbearance as the Pyramid of Cheops in its dimensions. Sooner or later all interurban railways must be transformed into subterranean. This will call for immense investments of capital, and if defective electrical apparatus is generally adopted the damage to life and property will be incalculable, not to speak of inconvenience to the public.

"It seems proper to me to acknowledge on this occasion the painstaking suggestions of some friends of mine, mostly unknown to me, both in the large domain of electrical achievement and in the small sphere of my friendship, to again address

the American Institute. It is customary with scientific men to present an original subject only once. I have done so and do not desire to depart from this established precedent. A lecture on the defects of the subway offers great opportunities, but would not be original. In view of certain insinuations I may cite a recently published statement of Mr. C. F. Scott, formerly president of the American Institute: 'As a matter of history it is the Tesla principle and the Tesla system which have been the directing factors in modern electrical engineering practice.' There are but a few men whose acknowledgment of my own work I would quote. Mr. Scott is one of them, as the man whose co-operation was most efficient in bringing about the great industrial revolution through these inventions. But the suggestions of my good friends have fallen on fruitful ground, and should it be possible for me to spare time and energy I may ask the city authorities for power to investigate the subway, and make a sworn report to them on all the defects and deficiencies I may discover, in the interest of public welfare.

"A few more words in relation to the signs. With all due respect to general opinion, I entertain quite a different view on that subject. Advertising is a useful art, which is being lifted continually to a higher plane, and will soon be quite respectable. It should not be hampered, but rather encouraged. I would give the Interborough Company every facility for exploiting it, restricting it only in so far as the artistic execution is concerned. A commission of capable men comprising a painter, a sculptor, an architect, a literary man, an engineer and an executive business man might be appointed, to pass upon the merits of the signs submitted for acceptance. I do not see why the public should object to them if they were regulated in this manner. They will further business, make travel less tedious, and help many skillful artisans. The subways are bound to become municipal property, and the city will then derive a revenue from them. What is most important for the safety of life and property, quickness and security of travel, should be first considered. All this depends on the electrical equipment. The engineers have built a good tunnel, and proper apparatus should be installed to match it.

Nikola Tesla
New York, Nov. 26

Manufacturers' Record
Dec. 29, 1904, p. 583.

ELECTRIC AUTOS.

Ni(c)ola Tesla's View of the Future in Motive Power.

(Special Cor. *Manufacturers' Record*.)

New York, December 27

In view of the great interest which is being taken in the articles published by the *Manufacturers' Record* and some of the magazines on the development of new power-producers, through the internal-combustion engine, for use for transportation purposes both by land and sea, the following signed statement, made by Mr. Ni(c)ola Tesla after a discussion of a new type of auto-bus designed by Mr. Charles A. Lieb, mechanical engineer of the Manhattan Transit Co., will doubtless be read with much general interest:

New York, December 17

Mr. Albert Phenix, Special Correspondent Manufacturers' Record, New York:

Dear Sir - Replying to your inquiry of yesterday, the application of electricity to the propulsion of automobiles is certainly a rational idea. I am glad to know that Mr. Lieb has undertaken to put it into practice. His long experience with the General Electric Co. and other concerns must have excellently fitted him for the task.

There is no doubt that a highly-successful machine can be produced on these lines. The field is inexhaustible, and this new type of automobile, introducing electricity between the prime mover and the wheels, has, in my opinion, a great future.

I have myself for many years advocated this principle. You will find in numerous technical publications statements made by me to this effect. In my article in the *Century*, June, 1900, I said, in dealing with the subject: 'Steamers and trains are still being propelled by the direct application of steam power to shafts or axles. A much greater percentage of the heat energy of the fuel could be transformed in motive energy by using, in place of the adopted marine engines and locomotives, dynamos driven by specially designed high-pressure steam or gas engines, by utilizing the electricity generated for the propulsion. A gain of 50 to 100 percent, in the effective energy derived from the fuel could be secured in this manner. It is difficult to understand why a fact so plain and obvious is not receiving more attention from engineers.

At first glance it may appear that to generate electricity by an engine and then apply the current to turn a wheel, instead of turning it by means of some mechanical connection with the engine, is a complicated and more or less wasteful process. But it is not so; on the contrary, the use of electricity in this manner secures great practical advantages. It is but a question of time when this idea will be extensively applied to railways and also to ocean liners, though in the latter case the conditions are not quite so favorable. How the railroad companies can persist in using the ordinary locomotive is a mystery. By providing an engine generating electricity and operating with the current motors under the cars a train can be propelled with greater speed and more economically. In France this has already been done by Heilman, and although his machinery was not the best, the results he obtained were creditable and encouraging. I have calculated that a notable gain in speed and economy can also be secured in ocean

liners, on which the improvement is particularly desirable for many reasons. It is very likely that in the near future oil will be adopted as fuel, and that will make the new method of propulsion all the more commendable. The electric manufacturing companies will scarcely be able to meet this new demand for generators and motors.

In automobiles practically nothing has been done in this direction, and yet it would seem they offer the greatest opportunities for application of this principle. The question, however, is which motor to employ - the direct-current or my induction motor. The former has certain preferences as regards the starting and regulation, but the commutators and brushes are very objectionable on an automobile. In view of this I would advocate the use of the induction motor as an ideally simple machine which can never get out of order. The conditions are excellent, inasmuch as a very low frequency is practicable and more than three phases can be used. The regulation should offer little difficulty, and once an automobile on this novel plan is produced its advantages will be readily appreciated.

Yours very truly,

N. Tesla.

Electrical World and Engineer
January 7, 1905, pp. 21-24

The Transmission of Electrical Energy Without Wires As a Means for Furthering Peace.

By NIKOLA TESLA.

UNIVERSAL PEACE, assuming it to be in the fullest sense realizable, might not require eons for its accomplishment, however probable this may appear, judging from the imperceptibly slow growth of all great reformatory ideas of the past. Man, as a mass in movement, is inseparable from sluggishness and persistence in his life manifestations, but it does not follow from this that any passing phase, or any permanent state of his existence, must necessarily be attained through a *stataclitic* process of development.

Our accepted estimates of the duration of natural metamorphoses, or changes in general, have been thrown in doubt of late. The very foundations of science have been shaken. We can no longer believe in the Maxwellian hypothesis of transversal ether-undulations and the literal truth of its corollaries. The practical utilization of electrical vibrations, this most important field of human endeavor, particularly in the advancement of philanthropy and peace, was in no small measure retarded by that fascinating illusion, which I since long hoped to dispel. I have noted with satisfaction the first signs of a change of scientific opinion. The brilliant discovery of the exceptionally "radio-active" substances, radium and polonium, by Mrs. Sklodowska Curie, has likewise afforded me much personal gratification, being an eclatant confirmation of my early experimental demonstrations, of electrified radiant streams of primary matter or corpuscular emanations (*Electrical Review*, New York, 1896-1897), which were then received with incredulity. They have awakened us from the poetical dream of an intangible conveyor of energy, weightless, structureless ether, to the plain, palpable reality of a ponderous medium of coarse particles, or bodily carriers of force. They have led us to a radically new interpretation of the changes and transformations we perceive. Enlightened by this recognition, we cannot say the sun is hot, the moon is cold, the star is bright, for all these might be purely electrical phenomena. If this be the case, then even our conceptions of time and space may have to be modified.

So, too, as regards the organic world, a similar revolution of thought is distinctly observable. In biological and zoological research the bold ideas of Haensel have found support in recent discoveries. A heretic belief in such possibilities as the artificial production of simple living material aggregates, the spontaneous natural creation of complex organisms and willful sex control, is gaining ground. We still brush it aside, but not with pedantic disdain as before. The fact is—our faith in the orthodox theory of slow evolution is being destroyed!

Thus a state of human life vaguely defined by the term "Universal Peace," while a result of cumulative effort through centuries past, might come into existence *quickly*, not unlike a crystal suddenly forms in a solution which has been slowly prepared. But just as no effect can precede its cause, so this state can never be *brought on* by any pact between nations, however solemn. Experience is made before the law is formulated, both are related like cause and effect.

Reprinted with permission. Reprinted from
Jan. 7, 1905, issue of *Electrical World*.

© Copyright 1905, McGraw-Hill, Inc. All
rights reserved.

So long as we are clearly conscious of the expectation, that peace is to result from such a parliamentary decision, so long have we a conclusive evidence that we are not fit for peace. Only then when we shall feel that such international meetings are mere formal procedures, unnecessary except in so far as they might serve to give definite expression to a common desire, will peace be assured.

To judge from current events we must be, as yet, very distant from that blissful goal. It is true that we are proceeding towards it rapidly. There are abundant signs of this progress everywhere. The race enmities and prejudices are decidedly waning. A recent act of His Excellency, the President of the United States, is significant in this respect. We begin to think cosmically. Our sympathetic feelers reach out into the dim distance. The bacteria of the "Weltschmerz," are upon us. So far, however, universal harmony has been attained only in a single sphere of international relationship. That is the postal service. Its mechanism is working satisfactorily, but—how remote are we still from that scrupulous respect of the sanctity of the mail bag! And how much farther again is the next milestone on the road to peace—an international judicial service equally reliable as the postal!

The coming meeting at the Hague, now indefinitely postponed, can only consider temporary expedients. General disarmament being for the present entirely out of question, a proportionate reduction might be recommended. The safety of any country and of the world's commerce depending not on the absolute, but relative amount of war material, this would be evidently the first reasonable step to take towards universal economy and peace. But it would be a hopeless task to establish an equitable basis of adjustment. Population, naval strength, force of army, commercial importance, water-power, or any other natural resource, actual or prospective, are equally unsatisfactory standards to consider.

In view of this difficulty a measure suggested by Carnegie might be adopted by a few strong countries to scare all the weaker ones into peace. But while for the time being such a course may seem advisable, the beneficial effects of this homœopathic treatment of the martial disease could hardly be lasting. In the first place, a coalition of the leading powers could not fail to create an organized opposition, which might result in a disaster all the greater as it was long deferred. The ultimate falling out of the virtuous, peace-dictating nations, as *certain* as the law of gravitation, should be all the more reckoned with, as it would be extremely demoralizing. Again, it is by no means demonstrated that any combination of a few powers would have sufficient authority.

To conquer by sheer force is becoming harder and harder every day. Defensive is getting continuously the advantage of offensive, as we progress in the satanic science of destruction. The new art of controlling electrically the movements and operations of individualized automata at a distance without wires, will soon enable any country to render its coasts impregnable against all naval attacks. It is to be regretted, in this connection, that my proposal to the United States Navy four years ago, to introduce this invention, did not receive the least encouragement. Also that my offer to Secretary Long to establish telegraphic communication across the Pacific Ocean by my wireless system was thrown in the naval waste basket in Washington, quite *sans façon*. At that time I had already announced in the *Century Magazine* of June, 1900, my successful "girdling" of the globe with electrical impulses (stationary waves), and my "telautomata" had been publicly exhibited. But that was not the fault of the naval officials, for then these inventions of mine were decried as bald, visionary schemes, loudest indeed by those who have since become Cræsus of Promise—in "light" storage batteries, "Ocean" telephony and "transatlantic" wireless telegraphy, yet remained to this day—Sisyphuses of Attainment. Had only a few "telautomatic" torpedoes been constructed and adopted by our navy, the mere moral influence of this would have been powerfully and most beneficially felt in the present Eastern complication.

Not to speak of the advantages which might have been secured through the direct and instantaneous transmission of messages to our distant colonies and scenes of the present barbarous conflicts. Since advancing that principle, I have invented a number of improvements, making it possible to direct such a torpedo, submersible at will, from a distance much greater than the range of the largest gun, with *unerring* precision, upon the object to be destroyed. What is still more surprising, the operator will not need to see the infernal engine or even know its location, and the enemy will be unable to interfere, in the slightest, with its movements by any electrical means. One of these devil-telautomata will soon be constructed, and I shall bring it to the attention of governments. The development of this art must unavoidably arrest the construction of expensive battleships as well as land fortifications, and revolutionize the means and methods of warfare. The distance at which it can strike, and the destructive power of such a *quasi-intelligent* machine being for all practical purposes unlimited, the gun, the armor of the battleship and the wall of the fortress, lose their import and significance. One can prophesy with a Daniel's confidence that skilled electricians will settle the battles of the near future. But this is the least. In its effect upon war and peace, electricity offers still much greater and more wonderful possibilities. To stop war by the perfection of engines of destruction alone, might consume centuries and centuries. Other means must be employed to hasten the end. What are these to be? Let us consider.

Fights between individuals, as well as governments and nations, invariably result from misunderstandings in the broadest interpretation of this term. Misunderstandings are always caused by the inability of appreciating one another's point of view. This again is due to the ignorance of those concerned, not so much in their *own*, as in their *mutual* fields. The peril of a clash is aggravated by a more or less predominant sense of combativeness, possessed by every human being. To resist this inherent fighting tendency the best way is to dispel ignorance of the doings of others by a systematic spread of general knowledge. With this object in view, it is most important to aid exchange of thought and intercourse.

Mutual understanding would be immensely facilitated by the use of one universal tongue. But which shall it be, is the great question. At present it looks as if the English might be adopted as such, though it must be admitted that it is not the most suitable. Each language, of course, excels in some feature. The English lends itself to a terse, forceful expression of facts. The French is precise and finely distinctive. The Italian is probably the most melodious and easiest to learn. The Slavic tongues are very rich in sound but extremely difficult to master. The German is unequaled in the facility it offers for coining and combining words. A practical answer to that momentous question must perforce be found in times to come, for it is manifest that by adopting one common language the onward march of man would be prodigiously quickened. I do not believe that an artificial concoction, like Volapuk, will ever find universal acceptance, however time-saving it might be. That would be contrary to human nature. Languages have grown into our hearts. I rather look to the possibility of a reversion to the old Latin or Greek mother tongues, basing myself in this conclusion on the Spencerian law of rhythm. It seems unfortunate that the English-speaking nations, who are now fittest to rule the world, while endowed with extraordinary energy and practical intelligence, are singularly wanting in linguistic talent.

Next to speech we must consider permanent records of all kinds as a means for disseminating general information, or that knowledge of *mutual* endeavor which is chiefly conducive to harmony. Here the newspapers play by far the most important part. They are undoubtedly more effective than institutions of learning, libraries, museums and individual correspondence, all combined. The knowledge they convey is, on the whole, superficial and sometimes defective, but it is poured out in a mighty stream that reaches

far and wide. Disregarding the force of electrical invention, that of journalism is the greatest in urging us to peace. Our schools are instrumental, mainly, in the furtherance of special thorough knowledge in our *own* fields, which is destructive of concordance. A world composed of crass specialists only would be perpetually at war. The diffusion of general knowledge through libraries and similar sources of information is very slow. As to individual correspondence, it is principally useful as an indispensable ingredient of the cement of commercial interest, that most powerful binding material between heterogeneous masses of humanity. It would be hard to overestimate the beneficial influence of the marvelous and precise art of photography, nor can that of other arts or means of recording be ignored. But a simple reflection will show that the peace-making force of all permanent, printed or other records, resides not in themselves. It must be sought elsewhere. This is also true of speech.

Our senses enable us to perceive only a minute portion of the outside world. Our touch, taste and smell, require actual contact. Our hearing extends to a small distance. Our sight is impeded by intervening bodies and shadows. To know each other we must reach beyond the sphere of our sense perceptions. We must transmit our intelligence, travel, transport the materials and transfer the energies necessary for our existence. Following this thought we now realize, forcibly enough to dispense with argument, that of all other conquests of man, without exception, that which is most desirable, which would be most helpful in the establishment of universal peaceful relations is—the complete *ANNIHILATION OF DISTANCE*.

To achieve this wonder, electricity is the one and only means. Inestimable good has already been done by the use of this all-powerful agent, the nature of which is still a mystery. Our astonishment at what has been accomplished would be uncontrollable were it not held in check by the expectation of greater miracles to come. That one, the greatest of all, can be viewed in three aspects: *Dissemination of intelligence, transportation, and transmission of power.*

Referring to the first, the present systems of telegraphic and telephonic communication are very limited in scope. The conducting channels are costly and of small working capacity. There is serious inductive disturbance, and storms render the service unsafe which, moreover, is too expensive: A vast improvement will be effected by placing the wires underground and insulating them artificially, by refrigeration. Their working capacity also could be indefinitely augmented by resorting to the new principle of "individualization," which I have more recently announced, permitting the simultaneous transmission of thousands of telegraphic and telephonic messages, without interference, over a single wire. The public would be already profiting from these great advances were it not for the stolid indifference of the leading companies engaged in the transmission of intelligence. But new concerns are springing into existence and the near future will witness a great transformation along these two lines of invention. The submarine cables are subject to still greater limitations. Some obstacles to rapid signaling, through them, seem insuperable. The attempts to overcome these have been numerous, but so far all have proved futile. The celebrated mathematician, O. Heaviside, and several able electricians following in his footsteps, have fallen into the singular error that rapid telegraphy and even telephony through ocean cables would be made practicable by the use of induction coils. Inductances might be to some extent helpful on comparatively short lines with thick paper insulation; on long lines insulated with rubber or gutta-percha they would be positively detrimental. Improvements will, undoubtedly, be made, but great electrostatic capacity and unavoidable loss of energy in the insulation and surrounding conductors will always restrict the usefulness of these delicate and precious nerves of commerce. Apart from all this, the transmission through artificial conductors is necessarily confined to a small number of stations.

It is therefore evident that the abolishment of all these drawbacks by the conveyance of signals or messages without wires, as I have undertaken in my "world" telegraphy and telephony, will be of the greatest moment in the furtherance of peace. The unifying influence of this advance will be felt all the more, as it will not only completely annihilate distance, but also make it possible to operate from a single "world" telegraphy plant, an unlimited number of receiving stations distributed all over the globe, and with equal facility, irrespective of location. Within a few years a simple and inexpensive device, readily carried about, will enable one to receive on land or sea the principal news, to hear a speech, a lecture, a song or play of a musical instrument, conveyed from any other region of the globe. The invention will also meet the crying need for cheap transmission to great distances, more especially over the oceans. The small working capacity of the cables and the excessive cost of messages are now fatal impediments in the dissemination of intelligence which can only be removed by transmission without wires.

The deficiencies of Hertzian telegraphy have created in the public mind the impression that exclusive or private messages without the use of artificial channels are impracticable. As a matter of fact, nothing could be more erroneous. Ever since its first appearance in 1891, I have denied the commercial possibilities of the system of signaling by Hertzian or electromagnetic waves, and my forecasts have been fully confirmed. It lends itself little to tuning, still less to the higher artifices of "individualization," and transmission to considerable distances is wholly out of the question. Portentous claims for this method of communication were made three years ago, but they have been unable to stand the hard, cruel test of time. Moreover, I have recently learned through the leading British electrical journal (*Electrician*, London, February 27, 1903), that some experimenters have abandoned all their own and have been "converted" to my methods and appliances, without my approval and officiation. I was both astonished and pained—astonished at the nonchalance and lack of appreciation of these men, pained at the inability exhibited in the construction and use of my apparatus. My high hopes raised by that excellent journal, however, are still to be realized, for I have ascertained that His Majesty the King of England, His Excellency the President of the United States, and other persons of exalted positions have, after all, not conferred upon me the imperishable honor of graciously condescending to the use of my coils, transformers and high-potential methods of transmission, but have exchanged their august greetings through the medium of a cable in the old-fashioned way. What has been actually achieved by Hertzian telegraphy can only be conjectured.

Quite different conditions exist in my system in which the electromagnetic waves or radiations are designedly minimized, the connection of one of the terminals of the transmitting circuit to the ground having, itself, the effect of reducing the energy of these radiations to about one-half. Under observance of proper rules and artifices the distance is of little or no consequence, and by skillful application of the principle of "individualization," repeatedly referred to the messages may be rendered both non-interfering and non-interferable. This invention, which I have described in technical publications, attempts to imitate, in a very crude way, the nervous system in the human body. It was the outcome of long-continued tests demonstrating the impossibility of satisfying rigorous commercial requirements by my earlier system, based on simple tuning, in which the selective quality is dependent on a single characteristic feature. In this later improvement the exclusiveness and non-interferability of impulses transmitted through a common channel result from cooperative association of a number of distinctive elements, and can be pushed as far as desired. In actual practice it is found that by combining only two vibrations or tones, a degree of privacy sufficient for most purposes is attained. When three vi-

brations are combined, it is extremely difficult, even for a skilled expert, to read or to disturb signals not intended for him, with four it is a vain undertaking. The probability of his getting the secret combinations at the right moments and in proper order, is much smaller than that of drawing an ambo, terno or quaterno, respectively, in a lottery. From experimental facts, I conclude that the invention will permit the simultaneous transmission of several millions of separately distinguishable messages through the earth, which, strangely enough, is in this respect much superior to an artificial conductor. This number ought to be sufficient to meet all the pressing necessities of intelligence transmission for at least one century to come. It is important to observe that but one "world" telegraphy plant, such as I am now completing, will have a greater working capacity than *all the ocean cables combined*. Once these facts are recognized this new art, which I am inaugurating, will sweep the world with the force of a uragan.

In transportation a great change is now going on. The trolley lines are being extended, the steam locomotive is making place for the electric motor. The ocean liners are adopting the turbine. Land travel is being improved by the automobile. The waterfalls are being harnessed and the energy used in the propulsion of cars. The advantages of first generating electricity by a prime mover, and then applying the current to produce mechanical motion, are being more and more appreciated. To the majority, this may appear a roundabout way of doing, but in reality it is as direct as the driving of a pulley from another by a belt. The idea is already being applied to railroads, and automobiles of this new type are making their appearance. The ocean vessels are bound to follow. An immense and virgin field will be thus opened up to the manufacturers of electric machinery. Effort towards saving time and money is characteristic of all modern methods of transportation. In many of these new developments, the artificial insulation of the high-tension mains by refrigeration will be very useful. However paradoxical, it is true, that by the use of this invention, power for all industrial purposes can be transmitted to distances of many hundreds of miles, not only without any loss, but with appreciable *gain* of energy. This is due to the fact that the conductor is much colder than the surrounding medium. The operativeness of this method is restricted to the use of a gaseous refrigerant, no known liquid permitting the attainment of a sufficiently low temperature of the transmission line. Hydrogen is by far the best cooling agent to employ. By its use electric railways can be extended to any desired distance. Owing to the smallness of ohmic loss, the objections to the multiphase system disappear and induction motors with closed coil armatures can be adopted. I find that even transmission through a submarine cable, as from Sweden to England, of great amounts of power is perfectly practicable. But the ideal solution of the problem of transportation will be arrived at only when the complete annihilation of distance in the transmission of power in large amounts shall have become a commercial reality. That day we shall invade the domain of the bird. When the vexing problem of aerial navigation, which has defied his attempts for ages, is solved, man will advance with giant strides.

That electrical energy can be economically transmitted without wires to any terrestrial distance, I have unmistakably established in numerous observations, experiments and measurements, qualitative and quantitative. These have demonstrated that it is practicable to distribute power from a central plant in unlimited amounts, with a loss not exceeding *a small fraction of one per cent.* in the transmission, even to the greatest distance, twelve thousand miles—to the opposite end of the globe. This seemingly impossible feat can now be readily performed by any electrician familiar with the design and construction of my "high-potential magnifying transmitter," the most marvelous electrical apparatus of which I have knowledge, enabling the production of effects of unlimited intensities

in the earth and its ambient atmosphere. It is, essentially, a freely vibrating secondary circuit of definite length, very high self-induction and small resistance, which has one of its terminals in intimate direct or inductive connection with the ground and the other with an elevated conductor, and upon which the electrical oscillations of a primary or exciting circuit are impressed under conditions of resonance. To give an idea of the capabilities of this wonderful appliance, I may state that I have obtained, by its means, spark discharges extending through more than one hundred feet and carrying currents of one thousand amperes, electromotive forces approximating twenty million volts, chemically active streamers covering areas of several thousand square feet, and electrical disturbances in the natural media *surpassing* those caused by lightning, in intensity.

Whatever the future may bring, the universal application of these great principles is fully assured, though it may be long in coming. With the opening of the first power plant, incredulity will give way to wonderment, and this to ingratitude, as ever before. The time is not distant when the energy of falling water will be man's life energy. So far only about three million horse-power have been harnessed by my system of alternating-current transmission. This is little, but corresponds, nevertheless, to the adding of sixty million indefatigable laborers, working virtually without food and pay, to the world's population. The projects which have come to my own attention, however, contemplate the exploitation of water-powers aggregating something like one hundred and fifty million horse-power. Should they be carried out in a quarter of a century, as seems probable from present indications, there will be, on the average two such untiring laborers for every individual. Long before this consummation, coal and oil must cease to be important factors in the sustenance of human life on this planet. It should be borne in mind that electrical energy obtained by harnessing a waterfall is probably fifty times more effective than fuel energy. Since this is the most perfect way of rendering the sun's energy available, the direction of the future material development of man is clearly indicated. He will live on "white coal." Like a babe in the mother's breast will he cling to his waterfall. "Give us our daily waterfall," will be the prayer of the coming generations. *Deus futurus est deus aquae deiectus!*

But the fact that stationary waves are producible in the earth is of special and, in many ways, still greater significance in the intellectual development of humanity. Popularly explained, such a wave is a phenomenon generically akin to an echo—a result of reflection. It affords a positive and uncontrovertible experimental evidence that the electric current, after passing into the earth travels to the diametrically opposite region of the same and rebounding from there, returns to its point of departure with virtually undiminished force. The outgoing and returning currents clash and form nodes and loops similar to those observable on a vibrating cord. To traverse the entire distance of about twenty-five thousand miles, equal to the circumference of the globe, the current requires a certain time interval, which I have approximately ascertained. In yielding this knowledge, nature has revealed one of its most precious secrets, of inestimable consequence to man. So astounding are the facts in this connection, that it would seem as though the Creator, himself, had electrically designed this planet just for the purpose of enabling us to achieve wonders which, before my discovery, could not have been conceived by the wildest imagination. A full account of my discoveries and improvements will be given to the world in a special work which I am preparing. In so far, however, as they relate to industrial and commercial uses, they will be disclosed in patent specifications most carefully drawn.

As stated in a recent article (*ELECTRICAL WORLD AND ENGINEER*, March 5, 1904), I have been since some time at work on designs of a power plant which is to transmit ten thousand horse-power

without wires. The energy is to be collected all over the earth at many places and in varying amounts. It should not be understood that the practical realization of this undertaking is *necessarily* far off. The plans could be easily finished this winter, and if some preliminary work on the foundations could be done in the meantime the plant might be ready for operation before the close of next fall. We would then have at our disposal a unique and invaluable machine. Just this *one* oscillator would advance the world a century. Its civilizing influence would be felt even by the humblest dweller in the wilderness. Millions of instruments of all kinds, for all imaginable purposes, could be operated from that one machine. Universal time could be distributed by simple inexpensive clocks requiring no attention and running with nearly mathematical precision. Stock-tickers, synchronous movements and innumerable devices of this character could be worked in unison all over the earth. Instruments might be provided for indicating the course of a vessel at sea, the distance traversed, the speed, the hour at any particular place, the latitude and longitude. Incalculable commercial advantages could be thus secured and countless accidents and disasters avoided. Here and there a house might be lighted or some other work requiring a few horse-power performed. What is far more important than this, flying machines might be driven in any part of the world. They could be made to travel swiftly because of their small weight and great motive power. My intention would be to utilize this first plant rather as means of enlightenment, to collect its power in very small amounts, and at as many places as possible. The knowledge that there is throbbing through the earth energy readily available everywhere, would exert a strong stimulus on students, mechanics and inventors of all countries. This would be productive of infinite good. Manufacture would receive a fresh and powerful incentive. Conditions, such as never existed before in commerce, would be brought about. Supply would be ever inadequate to demand. The industries of iron, copper, aluminum, insulated wire and many others, could not fail to derive great and lasting benefits from this development.

The economic transmission of power without wires is of all-surpassing importance to man. By its means he will gain complete mastery of the air, the sea and the desert. It will enable him to dispense with the necessity of mining, pumping, transporting and burning fuel, and so do away with innumerable causes of sinful waste. By its means, he will obtain at any place and in any desired amount, the energy of remote waterfalls—to drive his machinery, to construct his canals, tunnels and highways, to manufacture the materials of his want, his clothing and food, to heat and light his home—year in, year out, ever and ever, by day and by night. It will make the living glorious sun his obedient, toiling slave. It will bring peace and harmony on earth.

Over five years have elapsed since that providential lightning storm on the 3d of July, 1899, of which I told in the article before mentioned, and through which I discovered the terrestrial stationary waves; nearly five years since I performed the great experiment which, on that unforgettable day, the dark God of Thunder mercifully showed me in his vast, awe-sounding laboratory. I thought then that it would take a year to establish commercially my wireless girdle around the world. Alas! my first "world telegraphy" plant is not yet completed, its construction has progressed but slowly during the past two years. And this machine I am *building* is but a plaything, an oscillator of a maximum activity of only ten million horse-power, just enough to throw this planet into feeble tremors, by sign and word—to telegraph and to telephone: *When* shall I see completed that first power plant, that big oscillator which I am *designing*? From which a current stronger than that of a welding machine, under a tension of one hundred million volts, is to rush through the earth! Which will deliver energy

at the rate of one thousand million horse-power—one hundred Falls of Niagara combined in one, striking the universe with blows—blows that will wake from their slumber the sleepest electricians, if there be any, on Venus or Mars! . . . It is not a dream, it is a *simple feat of scientific electrical engineering*, only expensive—blind, faint-hearted, doubting world! . . . Humanity is not yet sufficiently advanced to be willingly led by the discoverer's keen searching sense. But who knows? Perhaps it is better in this present world of ours that a revolutionary idea or invention instead of being helped and patted, be hampered and ill-treated in its adolescence—by want of means, by selfish interest, pedantry, stupidity and ignorance; that it be attacked and stifled; that it pass through bitter trials and tribulations, through the heartless strife of commercial existence. *So* do we get our light. So all that was great in the past was ridiculed, condemned, combatted, suppressed—only to emerge all the more powerfully, all the more triumphantly from the struggle.

Electrical World and Engineer
June 24, 1905, p. 1162

TESLA ON SUBWAY DANGERS

The New York *Sun* of June 16 printed the following letter from Mr. Nikola Tesla:

The flooding of the subway is a calamity apt to repeat itself. As your readers will remember, it did not occur for the first time last Sunday. Water, like fire, will break loose occasionally in spite of precautions. It will never be possible to guard against a casual bursting of a main; for while the conduit can be safely relied upon under normal working conditions, any accidental obstruction to the flow may cause a pressure which no pipe or joint can withstand.

In fact, if we are to place faith in the gloomy forecasts of Commissioner Oakley, who ought to know, such floods may be expected to happen frequently in the future. In view of this it seems timely to call to public attention a danger inherent to the electrical equipment which has been thrust upon the Interborough Company by incompetent advisers.

The subway is bound to be successful, and would be so if the cars were drawn by mules, for it is the ideal means of transportation in crowded cities. But the full measure of success of which it is capable will be attained only when the financiers shall say to the electric companies: "Give us the best, regardless of expense."

It is to be regretted that this important pioneering enterprise, in other respects ably managed and engineered, should have been treated with such gross neglect in its most vital feature. No opportunity was given to myself, the inventor and patentee of the system adopted in the subway and the elevated roads, for offering some useful suggestion, nor was a single electrician or engineer of the General Electric and Westinghouse companies consulted, the very men who should have been thought of first of all.

Once large sums of money are invested in a defective scheme it is difficult to make a change, however desirable it may be. The movement of new capital is largely determined by previous investment. Even the new roads now planned are likely to be equipped with the same claptrap devices, and so the evil will grow. "Das eben ist der Fluch der boesen Thut, das sie fortzeugend Boeses muss gebaeren."

The danger to which I refer lies in the possibility of generating an explosive mixture by electrolytic decomposition and thermic dissociation of the water through the direct currents used in the operation of the cars. Such a process might go on for hours and days without being noticed; and with currents of this kind it is scarcely practicable to avoid it altogether.

It will be recalled that an expert found the percentage of free oxygen in the subway appreciably above that which might reasonably have been expected in such a more or less stagnated channel. I have never doubted the correctness of that analysis and have assumed that oxygen is being continuously set free by stray currents passing through the moist ground. The total amperage of the normal working current in the tunnel is very great, and in case of flooding would be sufficient to generate not far from 100 cubic feet of hydrogen per minute. Inasmuch, however, as in railway operation the fuses must be set hard, in order to avoid frequent interruption of the service by their blowing out, in such an emergency the current would be of much greater volume and hydrogen would be more abundantly liberated.

Reprinted with permission. Reprinted from June 24, 1905, issue of *Electrical World*.
© Copyright 1905, McGraw-Hill, Inc. All rights reserved.

It is a peculiar property of this gas that it is capable of exploding when mixed with a comparatively large volume of air, and any engineer can convince himself by a simple calculation that, say, 100,000 cubic feet of explosive might be formed before the danger is discovered, reported and preventive measures taken. What the effect of such an explosion might be on life and property is not pleasant to contemplate. True, such a disaster is not probable, but the present electrical equipment makes it possible, and this possibility should be, by all means, removed.

The oppressiveness of the tunnel atmosphere is in a large measure due to the heat supplied by the currents, and to the production of nitrous acid in the arcs, which is enhanced by rarefaction of the air through rapid motion. Some provision for ventilation is imperative. But ventilation will not do away with the danger I have pointed out. It can be completely avoided only by discarding the direct current.

I should say that the city authorities, for this if for no other reason, should forbid its use by a proper act of legislation. Meanwhile, the owners of adjacent property should object to its employment, and the insurance companies should refuse the grant of policies on such property except on terms which it may please them to make.

English Mechanic and World of Science
July 14, 1905, p. 515.

TESLA'S REPLY TO EDISON.

Says "We Shall Soon be Talking Round the World".

As we said last week, Mr. Edison was reported to have said in an interview of the *New York World* that he did not believe with Tesla in being able to talk round the world, but that he thought Marconi would, sooner or later, perfect his system.

Nikola Tesla has replied. He says:-

In the course of certain investigations which I carried on for the purpose of studying the effects of lightning discharges upon the electrical condition of the earth I observed that sensitive receiving instruments arranged so as to be capable of responding to electrical disturbances created by the discharges at times failed to respond when they should have done so, and upon inquiring into the causes of this unexpected behavior I discovered it to be due to the character of the electrical waves which were produced in the earth by the lightning discharges, and which had nodal regions following at definite distances the shifting source of the disturbances. From data obtained in a large number of observations of the maxima and minima of these waves I found their length to vary approximately from twenty-five to seventy kilometres, and these results and theoretical deductions led me to the conclusion that waves of this kind may be propagated in all directions over the globe, and that they may be of still more widely differing lengths, the extreme limits being imposed by the physical dimensions and properties of the earth. Recognising in the existence of these waves an unmistakable evidence that the disturbances created had been conducted from their origin to the most remote portions of the globe, and had been thence reflected, I conceived the idea of producing such waves in the earth by artificial means, with the object of using them for many useful purposes for which they are or might be found applicable.

Beat Lightning Flashes.

This problem was rendered extremely difficult, owing to the immense dimensions of the planet, and consequently enormous movement of electricity or rate at which electrical energy had to be delivered in order to approximate, even in a remote degree, movements or rates which are manifestly attained in the displays of electrical forces in nature, and which seemed at first unrealizable by any human agencies; but by gradual and continuous improvements of a generator of electrical oscillations, which I have described in my Patents Nos. 645,576 and 649,621, I finally succeeded in reaching electrical movements or rates of delivery of electrical energy not only approximately, but, as shown in comparative tests and measurements, actually surpassing those of lightning discharges and by means of this apparatus I have found it possible to reproduce, whenever desired, phenomena in the earth the same as or similar to those due to such discharges. With the knowledge of the phenomena discovered by me, and the means at command for accomplishing these results, I am enabled, not only to carry out many operations by the use of known instruments, but also to offer a solution for many important problems involving the operation or control of remote devices which, for want of this knowledge and the absence of these means, have heretofore been entirely impossible. For example, by the use of such a generator of stationary waves and receiving apparatus properly placed and adjusted in any other locality, however remote, it is practicable to transmit intelligible signals, or to control or actuate at will any one or all of such apparatus for many other important and valuable purposes, as for indicating whenever desired the correct time of an observatory, or for ascertaining the relative position of a body or distance of the same with reference to the given point, or for determining the course of a moving object, such as a vessel at sea, the distance traversed by the same or its speed; or for producing many other useful effects at a distance dependent on the intensity, wavelength, direction or velocity of movements, or other feature or property of disturbances of this character.

A Bit of Sarcasm.

Permit me to say on this occasion that if there exist to-day no facilities for wireless telegraphic and telephone communication between the most distant countries, it is merely because a series of misfortunes and obstacles have delayed the consummation of my labours, which might have been completed three years ago. In this connection I shall well remember the efforts of some, unwise enough to believe that they can gain an advantage by throwing sand in the eyes of the people and retarding the progress of invention. Should the first messages across the seas prove calamitous to them, it will be a punishment regrettable but fully deserved.

New York *Sun*
July 16, 1905

TESLA ON THE PEARY NORTH POLE EXPEDITION.

To the Editor of the New York *Sun*:-

Everybody must have been pleased to learn that Commodore Peary has finally obtained the financial assistance which will enable him to start without further delay on his important journey. Let us wish the bold navigator the most complete success in his perilous undertaking, in the interest of humanity as well as for his own and his companions' sake and the gratification of the generous donors who have aided him. But, while voicing these sentiments, let us hope that Peary's will be the last attempt to reach the pole in this slow, penible and hazardous way.

We have already sufficiently advanced in the knowledge of electricity and its applications to avail ourselves of better means of transportation, enabling us to reach and to explore without difficulty and in a more perfect manner not only the North, but also the South Pole, and any other still unknown regions of the earth's surface. I refer to the facilities afforded in this respect by the transmission of electrical energy without wires and aerial navigation, which has found in the novel art its ideal solution.

Many of your readers will, no doubt, be under the impression that I am speaking merely of possibilities. As a matter of fact, from the principles involved and the experiments which I have actually performed, not only is the practical success of such distribution of power reduced to a degree of mathematical certitude, but the transmission can be effected with an economy much greater than possible by the present method involving the use of wires.

It would not take long to build a plant for purposes of aerial navigation and geographical research, nor would it cost as much as might be supposed. Its location would be perfectly immaterial. It might be at the Niagara, or at the Victorian Falls in Africa, without any appreciable difference in the power collected in a flying machine or other apparatus.

A popular error, which I have often opportunity to correct, is to believe that the energy of such a plant would dissipate itself in all directions. This is not so, as I have pointed out in my technical publications. Electricity is displaced by the transmitter in all directions, equally through the earth and the air; that is true, but energy is expended only at the place where it is collected and used to perform some work. To illustrate, a plant of 10,000 hp, such as I have been planning, might be running full blast at Niagara, and there might be but one flying machine, of, say, 50 hp operating in some distant place, the location being of absolutely no consequence. In this case 50 hp would be all the power furnished by the plant to the rest of the universe. Although the electrical oscillations would manifest themselves all over the earth, at the surface as well as high in the air, virtually no power would be consumed. My experiments have shown that the entire electrical movement which keeps the whole globe a-tremble can be maintained with but a few horsepower. Apart from the transmitting and receiving apparatus, the only loss incurred is the energy radiated in the form of Hertzian or electro-magnetic waves, which can be reduced to any entirely insignificant quantity.

I appreciate the difficulty which your non-technical readers must experience in comprehending the working of this system. To gain a rough idea, let them imagine the transmitter and the earth to be two elastic bags, one very small and the other immense, both being connected by a tube and filled with some incompressible fluid. A pump is provided for forcing the fluid from one into the other, alternately and in rapid succession. Now, to produce a great movement of the fluid in a bag of

such enormous size as the earth would require a pump so large that it would be a greater task to construct it than to build a thousand Egyptian pyramids. But there is a way of accomplishing this with a pump of very small dimensions. The bag connected to the earth is elastic, and when suddenly struck vibrates at a certain rate. The first artifice consists in so designing and adjusting the parts that the natural vibrations of the bag are in synchronism with the strokes of the pump. Under such conditions the bag is set into violent vibrations, and the fluid is made to rush in and out with terrific force. But the immense bag - the earth, is still comparatively undisturbed. Its size, however, does not exempt it from the laws of nature, and just as the small bag, so too the earth, responds to certain impulses. This fact I discovered in 1899.

The second artifice is to so adjust the transmitter that it will furnish these particular impulses. When all is properly done the large bag is thrown into spasms of vibration, and the effects are bewildering. But no power is yet transmitted, and all this colossal movement requires little energy to maintain. It is like an engine running without load.

Next let your readers imagine that at any place where it may be desired to deliver energy a small elastic bag, not unlike the first, is connected to the large one through a tube. The third artifice consists in so proportioning the parts that the attachment will be responsive to the impulse transmitted, this resulting in a great intensification of the vibration of the bag. Still the pump will not furnish power until these vibrations are made to do work of some kind.

To conduce to an understanding of the fourth artifice, that of "individualization," let your readers follow me a step further, and conceive the flow of energy to any point can be controlled from the place where the pump is located at will, and with equal facility and precision, regardless of distance, and, furthermore, through a device such as the combination lock of a safe, they will then have a crude idea of the processes involved. But only when they realize that all these and many other processes not mentioned, and related to one another like the links of a chain, are completed in a fraction of a second, will your readers be able to appreciate the magical potencies of electrical vibrations and form a conception of the miracles which a skilled electrician can perform by the use of these appliances.

I earnestly hope that in the near future the conditions will be favorable for the construction of a plant such as I have proposed. As soon as this is done it will be possible to adapt electrical motors to flying machines of the type popularized by Santos Dumont. There will be no necessity of carrying a generator or store of motive energy and consequently the machine will be much lighter and smaller. Owing to this and also to the greater power available for propulsion, the speed will be considerably increased. But a few of such machines, properly equipped with photographic and other appliances, will be sufficient to give us in a short time an exact knowledge of the entire earth's surface. It should be borne in mind, however, that for the ordinary uses of a single person a very small machine of not more than one-quarter horse-power, corresponding to the work of two men, would be amply sufficient so that when the first plant of 10,000 hp is installed, the commodity of aerial flight can be offered to a great many individuals all the world over. I can conceive of no improvement which would be more efficient in the furtherance of civilization than this.

N. TESLA

Harvard Illustrated
March, 1907

SIGNALLING TO MARS - A PROBLEM OF ELECTRICAL ENGINEERING.

By Nikola Tesla.

In the early part of 1900, still vividly impressed by certain observations, I had made shortly before, and feeling that the time had come to prepare the world for an experiment which will soon be undertaken, I dwelt on the practicability of interplanetary signalling in an article which appeared in the June number of *Century Magazine* of the same year. In order to correct an erroneous report which gained wide circulation, a statement was published in *Collier's Weekly* of Feb. 9, 1901, defining my position in general terms. Ever since, my thoughts have been centred on the subject, and my original conviction has been strengthened both by reflection and suggestion.

Chief among the stimulating influences was the revelatory work of Percival Lowell, described in a volume with which the observatory, bearing his name, has honored me. No one can look at his globe of Mars without a feeling of profound astonishment, if not awe. These markings, still imperfectly discerned and incomprehensible, but evidently intended for a useful purpose, may they not contain a record of deep meaning left by a superior race, perhaps extinct, to tell its young brethren in other worlds of secrets discovered, of life and struggle, of their own terrible fate? What mighty pathos and love in such a gigantic drama of the universe! But let us hope that the astronomer has seen true, that Mars is not a cold grave, but the abode of happy intelligent creatures, from whom we may learn. In the light of this glorious possibility, signalling to that planet presents itself as a preeminently practical proposition which, to carry out, no human sacrifice could be too great. Can it be done? What chance is there that it will be done?

These questions will be answered definitely the moment all doubt as to the existence of highly developed beings on Mars is dispelled. The straightness of the lines on Lowell's map, their uniform width and other geometrical peculiarities, do not, themselves, appeal to me as strong proofs of artificiality. I should think that a planet large enough not to be frozen stiff in a spasm of volcanic action, like our moon, must, in the course of eons, have all its mountains leveled, the valleys filled, the rocks ground to sand, and ultimately assume the form of a smooth spheroid, with all its rivers flowing in geodetically straight lines. The uniform width of the waterways can be consistently explained, their crossings, however odd and puzzling, might be accidental. But I quite agree with Professor Morse, that this whole wonderful map produces the absolute and irresistible conviction, that these "canals" owe their existence to a guiding intelligence. Their great size is not a valid argument to the contrary. It would merely imply that the Martians have harnessed the energy of waterfalls. We know of no other source of power competent to explain such tremendous feats of engineering. They could not be accomplished by capturing the sun's rays or abstracting heat imparted to the atmosphere, for this, according to our best knowledge, would require clumsy and inefficient machinery. Large falls could be obtained near the polar caps by extensive dams. While much less effective than our own, they could well furnish several billions of horse-power. It should be borne in mind that many Martian tasks in mechanical engineering are much easier than the terrestrial, on account of the smaller mass of the planet and lesser density, which, in the superficial layers, may be considerably below the mean. To a still greater degree this is

true of electrical engineering. Taking into account the space encompassed by Mars, a system of wireless transmission of energy, such as I have perfected, would be there much more advantageously applied, for, under similar conditions, a receiving circuit would collect sixteen times as much energy as on the earth.

The astonishing evidences furnished by Lowell are not only indicative of organic life, but they make it appear very probable that Mars is still populated; and furthermore, that its inhabitants are highly developed intelligent beings. Is there any other proof of such existence? I answer, emphatically, yes, prompted both by an instinct which has never yet deceived me, and observation. I refer to the strange electrical disturbances, the discovery of which I announced six years ago. At that time I was only certain that they were of planetary origin. Now, after mature thought and study, I have come to the positive conclusion that they must emanate from Mars.

Life, as a great philosopher has said, is but a continuous adjustment to the environment. Similar conditions must bring forth similar automata. We can have no idea what a Martian might be like, but he certainly has sensitive organs, much as our own, responsive to external stimuli. The indications of these instruments must be real and true. A straight line, a geometrical figure, a number, must convey to his mind a clear and definite conception. He ought to think and reason like ourselves. If he breathes, eats and drinks, he is moved by motives and desires not very different from our own. Such colossal transformation as is observable on the face of Mars could not have been wrought except by beings ages ahead of us in development. What wonder, then, if they have maps of this, our globe, as perfect as Professor Pickering's photographs of the moon? What wonder if they are signalling to us? We are sufficiently advanced in electrical science to know that their task is much easier than ours. The question is, can we transmit electrical energy to that immense distance? This I think myself competent to answer in the affirmative.

N. Tesla

English Mechanic and World of Science
 March 8, 1907, pp. 107, 108

TUNED LIGHTNING
 by Nikola Tesla

I read with interest an article in the *Sunday World* of Jan. 20 on "Tuned Lightning," described as a mysterious new energy, which is to turn every wheel on earth, and is supposed to have been recently discovered by the Danish inventors Waldemar Poulsen and P. O. Pederson.

From other reports I have gathered that these gentlemen have so far confined themselves to the peaceful production of miniature bolts not many inches long, and I am wondering what an account of their prospective achievements would read like if they had succeeded in obtaining, like myself, electrical discharges of 100 ft., far surpassing lightning in some features of intensity and power.

In view of their limited Jovian experience, the programme outlined by the Danish engineers is rather extensive, Lord Armstrong's vast resources notwithstanding. Naturally enough, I shall look with interest to their telephoning across the Atlantic, supplying light and propelling airships without wires. *Anch in suito pittore.* (I, too, am a painter.) In the mean time it may not be amiss to state here incidentally that all the essential processes of and appliances for the generation, transmission, transformation, distribution, storage, regulation, control, and economic utilisation of "tuned lightning" have been patented by me, and that I have long since undertaken, and am sparing no effort to render these advances instrumental in insuring the welfare, comfort, and convenience, primarily, of my fellow citizens.

There is nothing remarkable in the demonstration reported to have been made before Sir William Preece and Prof. Sylvanus P. Thompson, nor is there any novelty in the electrical devices employed. The lighting of arc lamps through the human body, the fusing of a piece of copper in mid-air, as described, are simple experiments which by the use of my high-frequency transformers any student of electricity can readily perform. They teach nothing new, and have no bearing on wireless transmission, for the actions virtually cease at a distance of a few feet from the source of vibratory energy. Years ago I gave exhibitions of similar and other much more striking experiments with the same kind of apparatus, many of which have been illustrated and explained in technical journals. The published records are open to inspection.

Regardless of all that, the Danish inventors have not as yet offered the slightest proof that their expectations are realisable, and before advancing seriously the claim that an efficient wireless distribution of light and power to great distances is possible, they should, at least, repeat those of my experiments which have furnished this evidence.

A scientific audience cannot help being impressed by a display of interesting phenomena, but the originality and significance of a demonstration such as that referred to can only be judged by an expert possessed of full knowledge and capable of drawing correct conclusions. A novel effect, spectacular and surprising, might be quite unimportant, while another, seemingly trifling, is of the greatest consequence.

To illustrate, let me mention here two widely different experiments of mine. In one the body of a person was subjected to the rapidly-alternating pressure of an electrical oscillator of two and a half million volts; in the other a small incandescent lamp was lighted by means of a resonant circuit grounded on one end, all the energy being drawn through the earth electrified from a distant transmitter.

The first presents a sight marvellous and unforgettable. One sees the experimenter standing on a big sheet of fierce, blinding flame, his whole body enveloped in a mass of phosphorescent wriggling streamers like the tentacles of an octopus. Bundles of light stick out from his spine. As he stretches out the arms, thus forcing the electric fluid outwardly, roaring tongues of fire leap from his fingertips. Objects in his vicinity bristle with rays, emit musical notes, glow, grow hot. He is the centre of still more curious actions, which are invisible. At each throb of the electric force myriads of minute projectiles are shot off from him with such velocities as to pass through the adjoining walls. He is in turn being violently bombarded by the surrounding air and dust. He experiences sensations which are indescribable.

A layman, after witnessing this stupendous and incredible spectacle, will think little of the second modest exhibit. But the expert will not be deceived. He realizes at once that the second experiment is ever so much more difficult to perform and immensely more consequential. He knows that to make the little filament glow, the entire surface of the planet, two hundred million square miles, must be strongly electrified. This calls for peculiar electrical activities, hundreds of times greater than those involved in the lighting of an arc lamp through the human body. What impresses him most, however, is the knowledge that the little lamp will spring into the same brilliancy anywhere on the globe, there being no appreciable diminution of the effect with the increase of distance from the transmitter.

This is a fact of overwhelming importance, pointing with certitude to the final and lasting solution of all the great social, industrial, financial, philanthropic, international, and other problems confronting humanity, a solution of which will be brought about by the complete annihilation of distance in the conveyance of intelligence, transport of bodies and materials, and the transmission of the energy necessary to man's existence. More light has been thrown on this scientific truth lately through Prof. Slaby's splendid and path-breaking experiment in establishing perfect wireless telephone connection between Naum and Berlin, Germany, a distance of twenty miles. With apparatus properly organised such telephonic communication can be effected with the same facility and precision at the greatest terrestrial distance.

The discovery of the stationary terrestrial waves, showing that, despite its vast extent, the entire planet can be thrown into resonant vibration like a little tuning fork; that electrical oscillations suited to its physical properties and dimensions pass through it unimpeded, in strict obedience to a simple mathematical law, has proved beyond the shadow of a doubt that the earth, considered as a channel for conveying electrical energy, even in such delicate and complex transmissions as human speech or musical composition, is infinitely superior to a wire or cable, however well designed.

Very soon it will be possible to talk across an ocean as clearly and distinctly as across a table. The first practical success, already forecast by Slaby's convincing demonstration, will be the signal for revolutionary improvements which will take the world by storm.

However great the success of the telephone, it is just beginning its evidence of usefulness. Wireless transmission of speech will not only provide new but also enormously extend existing facilities. This will be merely the forerunner of ever so much more important development, which will proceed at a furious pace until, by the application of these same great principles, the power of waterfalls can be focussed whenever desired; until the air is conquered, the soil fructified and embellished; until, in all departments of human life distance has lost its meaning, and even the immense gulf separating us from other worlds is bridged.

New York Times

March 20, 1907, p. 8, col. 5.

TESLA'S WIRELESS TORPEDO

Inventor Says He Did Show That it Worked Perfectly

To the Editor of *The New York Times*:

A report in the Times of this Morning says that I have attained no practical results with my dirigible wireless torpedo. This statement should be qualified. I have constructed such machines, and shown them in operation on frequent occasions. They have worked perfectly, and everybody who saw them was amazed at their performance.

It is true that my efforts to have this novel means for attack and defense adopted by our Government have been unsuccessful, but this is no discredit to my invention. I have spent years in fruitless endeavor before the world recognized the value of my rotating field discoveries which are now universally applied. The time is not yet ripe for the telautomatic art. If its possibilities were appreciated the nations would not be building large battleships. Such a floating fortress may be safe against an ordinary torpedo, but would be helpless in a battle with a machine which carries twenty tons of explosive, moves swiftly under water, and is controlled with precision by an operator beyond the range of the largest gun.

As to projecting wave-energy to any particular region of the globe, I have given a clear description of the means in technical publications. Not only can this be done by the use of my devices, but the spot at which the desired effect is to be produced can be calculated very closely, assuming the accepted terrestrial measurements to be correct. This, of course, is not the case. Up to this day we do not know a diameter of the globe within one thousand feet. My wireless plant will enable me to determine it within fifty feet or less, when it will be possible to rectify many geodetical data and make such calculations as those referred to with greater accuracy.

Nikola Tesla

New York, March 19, 1907

New York Times

March 26, 1907, p. 8, col. 7.

WIRELESS ON RAILROADS

Nikola Tesla Says It Is Perfectly Practical and Will Soon Be In Use.

To the Editor of *The New York Times*:

No argument is needed to show that the railroads offer opportunities for advantageous use of a practical wireless system. Without question, its widest field of application is the conveyance to the trains of such general information as is indispensable for keeping the traveler in touch with the world. In the near future a telegraphic printer of news, a stock ticker, a telephone, and other kindred appliances will form parts of the regular wireless equipment of a railroad train. Success in this sphere is all the more certain, as the new is not antagonistic, but, on the contrary, very helpful to the old. The technical difficulties are minimized by the employment of a transmitter the effectiveness of which is unimpaired by distance.

In view of the great losses of life and property, improved safety devices on the cars are urgently needed. But upon careful investigation it will be found that the outlook in this direction is not very promising for the wireless art. In the first place the railroads are rapidly changing to electric motive power, and in all such cases the lines become available for the operation of all sorts of signaling apparatus, of which the telephone is by far the most important. This valuable improvement is due to Prof. J. Paley, who introduced it in Germany eight years ago. By enabling the engineer or conductor of any train to call up any other train or station along the track and obtain full and unmistakable information, the liability of collisions and other accidents will be greatly reduced. Public opinion should compel the immediate adoption of this invention.

Those roads which do not contemplate this transformation might avail themselves of wireless transmission for similar purposes, but inasmuch as every train will require in addition to a complete outfit an expert operator, many roads may prefer to use a wire, unless a wireless telephone can be offered to them.

NIKOLA TESLA

New York, March 25, 1907

New York Times
May 2, 1907, p. 8, col. 6.

NI(C)OLA TESLA OBJECTS.

Thinks He Should Receive Credit for His Own Inventions.

To the Editor of *The New York Times*:

I have been much surprised to read in *The Times* of Sunday, April 21, that Admiral H. N. Manney, U.S.N. attributes a well-known invention of mine, a process for the production of continuous electrical oscillations by means of the electric arc and condenser, to Valentine Poulsen, the Danish engineer. This improvement has been embodied by me in numerous forms of apparatus identified with my name, and I have described it minutely in patents and scientific articles. To quote but one of many references, I may mention my experimental lecture on "Light and Other High-Frequency Phenomena," published under the auspices of the Franklin Association, for which both of these societies have distinguished me.

I share with Admiral Manney in the gratification that we are in the lead, and particularly that wireless messages have been transmitted from Pensacola to Point Lorne. Inasmuch, however, as this feat could not have been accomplished except by the use of some of my own devices, it would have been a graceful act on his part to bring this feat to the attention of the wireless conference. My theory has always been that military men are superior to civilians in courtesy. I have not been discouraged by the refusal of our Government to adopt my wireless system six years ago, when I offered it, not by the unpleasant prospect of my passing through the experiences described by Mark Twain in his story of the beef contract, but I see no reason why I should be deprived of a well-earned honor and satisfaction.

The *Times* has hurt me grievously; not by accusing me of commercialism, nor by its unkind editorial comments on those letters I wrote, in condemnation of my system of power transmission in the Subway. It is another injury, perhaps, unintentional, which I have felt most keenly.

The editor of *The Times* may not have known that I am a student of applied mathematics when he permitted a fellow student of mine to insinuate in *The Times* of

March 28 that I avail myself of inventions of others. I cannot permit such ideas to gain ground in this community, and, just to illuminate the situation, I shall quote from the leading electrical paper, *The London Electrician*, referring to some wireless plants of Braun and Marconi: "The spark occurs between balls in the primary circuit of a Tesla coil. The air wire***is in series with a Tesla transformer ***The generating plant is virtually a Poldhu in miniature. Evidently Braun, like Marconi, has been converted to the high-potential methods introduced by Tesla." Needless to add that this substitution of the old, ineffective Hertzian appliances for my own has not been authorized by me.

My fellow-student can rest assured that I am scrupulously respecting the rights of others. If I were not prompted to do so by a sense of fairness and pride I would be by the power I have of inventing anything I please.

N. TESLA

New York, April 30, 1907

English Mechanic and World of Science

May 3, 1907, p. 296.

(From the *New York World*)

TESLA'S TIDAL WAVE TO MAKE WAR IMPOSSIBLE.

by Nikola Tesla

Just at this time, when all efforts towards peaceful arbitration notwithstanding, the nations are preparing to expend immense sums in the design and construction of monstrous battleships, it may be useful to bring to the attention of the general public a singular means for naval attack and defense, which the telautomatic art has made possible, and which is likely to become a deciding factor in the near future.

A few remarks on this invention, of which the wireless torpedo is but a special application, are indispensable to the understanding and full appreciation of the naval principle of destruction.

The telautomatic art is the result of endeavours to produce an automaton capable of moving and acting as if possessed of intelligence and distinct individuality. Disconnected from its higher embodiment, an organism, such as a human being, is a heat - or thermodynamic engine - comprising:- (1) a complete plant for receiving, transforming, and supplying energy; (2) apparatus for locomotion and other mechanical performance; (3) directive organs; and (4) sensitive instruments responsive to external influences, all these parts constituting a whole of marvelous perfection.

The ambient medium is alive with movement and energy, in a state of unceasing agitation which is beyond comprehension. Strangely enough, to most of this terrible turmoil the human machine is insensible. The automaton does not feel the weight of the atmosphere crushing him with a force of 16 tons. He is unaffected by the shower of particles shooting through his body of cloud and the hurricane of finer substance rushing through him with the speed of light. He is unconscious that he is being whisked through space at the fearful rate of 70,000 miles an hour. But when gentle waves of light or sound strike him his eye and ear respond, his resonant nerve-fibres transmit the vibrations and his muscles contract and relax. Thus, like a float on a turbulent sea, swayed by external influences, he moves and acts. The average person is not aware of this constant dependence on his environment, but a trained observer has no difficulty in locating the primary disturbance which prompts

him into action, and continued exercise soon satisfies him that virtually all of his purely mechanical motions are caused by visual impressions, directly or indirectly received.

USING THE PRINCIPLES OF HUMAN ACTION.

A machine of such inconceivable complexity as the body of an organised being, capable of an infinite variety of actions, with controlling organs supersensitive, responsive to influences almost immaterial, cannot be manufactured by man; but the mechanical principles involved in the working of the living automaton are also applicable to an inanimate engine, however crude.

An automobile boat was first employed to carry out the idea. Its storage battery and motor furnished the power; the propeller and rudder, respectively, served as locomotive and directive organs, and a very delicate electrical device, actuated by a circuit tuned to a distant transmitter, took the place of the ear. This mechanism followed perfectly the wireless signals or comments of the operator in control of the transmitter, performing every movement and action as if it had been gifted with intelligence.

The next step was to individualise the machine. The attunement of the controlling circuits gave it a special feature, but this was not sufficiently distinctive. An individuality implies a number of characteristic traits which, though perhaps extant elsewhere, are unique in that particular combination. Here again the animated automaton, with its nerve-signal system, was coarsely imitated. The action of the delicate device - the ear - was made dependent on a number of sensitised receiving circuits, each recognisable by its own free vibrations, and all together by the character of their operative combination. Correspondingly the transmitter was designed to emit a wave-complex exactly matching the combination in the number and pitch of individual vibrations, their groupment and order of succession.

WONDERS OF THE NEW TELAUTOMATON.

That much is done, but more is to come. A mechanism is being perfected which without operator in control, left to itself, will behave as if endowed with intelligence of its own. It will be responsive to the faintest external influences and from these, unaided, determine its subsequent actions as if possessed of selective qualities, logic, and reason. It will perform the duties of an intelligent slave. Many of us will live to see Bulwer's dream realised.

The reader for whom the preceding short explanation of this novel art is intended may think it simple and easy of execution, but it is far from being so. It has taken years of study and experiment to develop the necessary methods and apparatus, and five inventions, all more or less fundamental and difficult to practise, must be employed to operate successfully and individualised telautomaton.

Such a novel engine of war - a vessel of any kind, submarine or aerial - carrying an agent of unlimited potency of destruction, with no soul aboard, yet capable of doing all it is designed for, as if fully equipped with a fearless crew in command of its captain, must needs bring on a revolution in the present means of attack and defence.

Since ages human ingenuity has been bent upon inventing infernal machines. Of these the modern cannon has been so far the most remarkable. A 12 in. gun charged with cordite is said to hurl a projectile of 850 lb. with the initial velocity of nearly 2,900 ft. per second, imparting to it the energy of 110,000,000 ft. lb. Were it not for the resistance of the air such a projectile would travel about fifty miles before striking the ground. It would take 3,300 H. P. more than a minute to accumulate its mechanical energy. Bear in mind, however, that all this energy is

imparted to the projectile while it is being urged through the gun-barrel with a mean force of 1,100 tons. If the barrel is 50 ft. long and the average velocity through it 1,500 ft. per second, the whole energy is transferred to a moving mass in 1/30th of a second; hence the rate of performance is 1,800 times the above-that is about 6,000,000 H.P. This seems wonderful indeed, but is nothing as compared with rates obtained by other means. Electricity can be stored in the form of explosive energy of a violence against which the detonation of cordite is but a breath. With a magnifying transmitter as diagrammatically illustrated, rates of 25,000,000 H.P. have already been obtained. A similar and much improved machine, now under construction, will make it possible to attain maximum explosive rates of over 800,000,000 H.P., twenty times the performance of the *Dreadnought's* broadside of eight 12 in. guns simultaneously fired. These figures are so incredible that astronomers unacquainted with the marvellous appliance have naturally doubted the practicability of signaling to Mars. In reality, by its means the seemingly visionary project has been reduced to a rational engineering problem.

The time is not far distant when all the tremendous wastes of war will be stopped, and then, if there are battles, they will be fought with water-power and electrical waves. That humanity is moving fast towards this realisation is evident from many indications.

What is most to be regretted in the present war *régime* is that the effort of so many exquisite intelligences must be uneconomically applied, since it cannot be entirely governed by the wavering struggle of opposing principles. This feverish striving to meet the instant demand, to create type after type, one to devour the other, to merge into one contrasting element, leads, like a nightmare, from one to another absurdity. Such a monstrosity is the latest creation of the naval constructor - a 20,000 ton battleship. In theory it is condemned by competent authorities.

Everything points to the development of a small vessel with internal combustion engines, extreme speed, and few weapons of great destructiveness. But the new leviathan is admirably adapted to the practical requirements of the day. In attack it could alone annihilate a nation's fleet. It is equally effective in defence. If equipped with proper acoustic and electrical appliances it has little to fear from a submarine, and an ordinary torpedo will scarcely hurt it. That is why the first of these monsters, built in England, has been named *Dreadnought*. Now, there is a novel means for attacking a fortress of this kind, from shore or on the high seas, against which all its gun-power and armour resistance are of no avail. It is the tidal wave.

WHAT THE TESLA TIDAL WAVE WILL DO.

Such a wave can be produced with twenty or thirty tons of cheap explosive, carried to its destination and ignited by a non-interferible telautomaton.

The tidal disturbance, as here considered, is a peculiar hydrodynamic phenomenon, in many respects different from the commonly occurring, characterised by a rhythmical succession of waves. It consists generally of but a single advancing swell succeeded by a hollow, the water if not otherwise agitated being perfectly calm in front and very nearly so behind. The wave is produced by some sudden explosion or upheaval, and is, as a rule, asymmetrical for a large part of its course. Those who have encountered a tidal wave must have observed that the sea rises rather slowly, but the descent into the trough is steep. This is due to the fact that the water is lifted, possibly very slowly, under the action of a varying force, great at first, but dying out quickly, while the raised mass is urged downward by the constant force of gravity. When produced by natural causes these waves are not very dangerous to ordinary vessels, because the disturbance originated at a great depth.

To give a fairly accurate idea of the efficacy of this novel means of destruction, particularly adapted for the coast defence, it may be assumed that thirty tons of nitro-glycerine compound, as dynamite, be employed to create the tidal disturbance. This material, weighing about twice as much as water, can be stored in a cubical tank 8 ft. each way, or a spherical vessel of 10 ft. diameter. The reader will now understand that this charge is to be entrusted to a non-interferible tel-automaton, heavily protected, and partly submerged or submarine, which is under perfect control of a skilled operator far away. At the propitious moment the signal is given, the charge sunk to the proper depth and ignited.

The water is incompressible. The hydrostatic pressure is the same in all directions. The explosion propagates through the compound with a speed of three miles a second. Owing to all this, the whole mass will be converted into gas before the water can give way appreciably, and a spherical bubble 10 ft. in diameter will form. The gaseous pressure against the surrounding water will be 20,000 atmospheres, or 140 tons per square inch. When the great bubble has expanded to twice its original volume it will weigh as much as the water it displaces, and from that moment on, its lower end tapering more and more into a cone, it will be driven up with a rapidly-increasing force tending towards 20,000 tons. Under the terrific impulsion it would shoot up the surface like a bullet were it not for the water resistance, which will limit its maximum speed to 80 ft. per second.

Consider not the quantity and energy of the upheaval. The caloric potential energy of the compound is 2,800 heat units per pound, or, in mechanical equivalent, almost 1,000 ft.-tons. The entire potential energy of the explosive will thus be 66,000,000 ft.-tons. Of course, only a part of this immense store is transformable into mechanical effort. Theoretically, 40 lb. of good smokeless powder would be sufficient to impart to the *Dreadnought's* 850 lb. projectile the tremendous velocity mentioned above, but it actually takes a charge of 250 lb. The tidal wave generator is a dynamic transformer much superior to the gun, its greatest possible efficiency being as high as 44 per cent. Taking, to be conservative, 38 per cent, instead, there will be the total potential store about 25 million foot-tons obtained in mechanical energy.

HOW THE ENEMY WOULD BE ENGULFED.

Othwise stated, 25,000,000 tons - that is, 860,000,000 cu. ft. of water, could be raised 1 ft., or a smaller quantity to a correspondingly greater elevation. The height and length of the wave will be determined by the depth at which the disturbance originated. Opening in the centre like a volcano, the great hollows will belch forth a shower of ice. Some sixteen seconds later a valley of 600 ft. depth, counted from normal ocean level, will form, surrounded by a perfectly circular swell, approximately of equal height, which will enlarge in diameter at the rate of about 220 ft. per second.

It is futile to consider the effect of such an eruption on a vessel situated nearby, however large. The entire navy of a great country, if massed around, would be destroyed. But it is instructive to inquire what such a wave could do to a battleship of the Dreadnought type at considerable distance from its origin. A simple calculation will show that when the outer circle has expanded to three-quarters of a mile, the swell, about 1,250 ft. long, would still be more than 100 ft. in height, from crest to normal sea level, and when the circle is one and one-quarter mile in diameter the vertical distance from crest to trough will be over 100 ft.

The first impact of the water will produce pressures of three tons per square foot, which all over the exposed surface of, say, 20,000 sq. ft., may amount to 60,000 tons, eight times the force of the recoil of the broadside. That first

impact may in itself be fatal. During more than ten seconds the vessel will be entirely submerged and finally dropped into the hollow from a height of about 75 ft., the descent being effected more or less like a free fall. It will then sink far below the surface, never to rise.

N. Y. World
May 19, 1907

THE PEOPLE'S FORUM.

Mr. Tesla on the Wireless Transmission of Power.
To the Editor of The World:

I have enjoyed very much the odd prediction of Sir Hugh Bell, President of the Iron and Steel Institute, with reference to the wireless transmission of power, reported in *The World* of the 10th inst.

With all the respect due to that great institution I would take the liberty to remark that if its President is a genuine prophet he must have overslept himself a trifle. Sir Hugh would honor me if he would carefully peruse my British patent No. 8,200, in which I have recorded some of my discoveries and experiments, and which may influence him to considerably reduce his conservative estimate of one hundred years for the fulfillment of his prophecy.

Personally, basing myself on the knowledge of this art to which I have devoted my best energies, I do not hesitate to state here for future reference and as a test of accuracy of my scientific forecast that flying machines and ships propelled by electricity transmitted without wire will have ceased to be a wonder in ten years from now. I would say five were it not that there is such a thing as "inertia of human opinion" resisting revolutionary ideas.

It is idle to believe that because man is endowed with higher attributes his material evolution is governed by other than general physical laws. If the genius of invention were to reveal to-morrow the secret of immortality, of eternal beauty and youth, for which all humanity is aching, the same inexorable agents which prevent a mass from changing suddenly its velocity would likewise resist the force of the new knowledge until time gradually modifies human thought.

What has amused me still more, however, is the curious interview with Lewis Nixon, the naval contractor, printed in the *World* of the 11th inst. Is it possible that the famous designer of the Oregon is not better versed in editorial matters than some of my farming neighbors of Shoreham? One cannot escape that conviction.

We are not in the dark as regards the electrical energy contained in the earth. It is altogether too insignificant for any industrial use. The current circulating through the globe is of enormous volume but of small tension, and could perform but little work. Beside, how does Nixon propose to coax the current from the natural path of low resistance into an artificial channel of high resistance? Surely he knows that water does not flow up hill. It is absurd of him to compare the inexhaustible dynamic energy of wind with the magnetic energy of the earth, which is minute in amount and in a static condition.

The torpedo he proposes to build is not novel. The principle is old. I could refer him to some of my own suggestions of nine years ago. There are many practical difficulties in the carrying out of the idea, and as much better means for destroying a submarine are available it is doubtful that such a torpedo will ever be constructed.

Nixon has failed to grasp that in my wireless system the effect does not diminish with distance. The Hertz waves have nothing to do with it except that some of my apparatus may be used in their production. So too a Kohinoor might be employed to cut window-glass. And yet, the seeming paradox can be easily understood by any man of ordinary intelligence.

Imagine only that the earth were a hollow shell or reservoir in which the transmitter would compress some fluid, as air, for operating machinery in various localities. What difference would it make when this reservoir is tapped to supply the compressed fluid to the motor? None whatever, for the pressure is the same everywhere. This is also true of my electrical system, with all considerations in its favor. In such a mechanical system of power distribution great losses are unavoidable and definite limits in the quality of the energy transmitted exist. Not so in the electrical wireless supply. It would not be difficult to convey to one of our liners, say, 50,000 horsepower from a plant located at Niagara, Victoria or other waterfall, absolutely irrespective of location. In fact, there would not be a difference of more than a small fraction of one per cent, whether the source of energy be in the vicinity of the vessel or 12,000 miles away, at the antipodes.

NIKOLA TESLA

New York, May 16, 1907.

New York Times
June 23, 1907

CAN BRIDGE THE GAP TO MARS.

Nikola Tesla on His Wireless System for the Transmission of Energy.

To the Editor of the New York Times:

You have called me an "inventor of some useful pieces of electrical apparatus". It is not quite up to my aspirations, but I must resign myself to my prosaic fate. I cannot deny that you are right.

Nearly four million horse power of waterfalls are harnessed by my alternating current system of transmission, which is like saying that one hundred million men-untiring, consuming nothing, receiving no pay - are laboring to provide for one hundred million tons of coal annually. In this great city the elevated roads, the subways, the street railways are operated by my system, and the lamps and other electrical appliances get the current through machinery of my invention. And as in New York so all the world over where electricity is introduced. The telephone and incandescent lamp fill specific and minor demands, electric power meets the many general and sterner necessities of life. Yes, I must admit, however reluctantly, the truth of your unflattering contention.

But the greater commercial importance of this invention of mine is not the only advantage I have over my celebrated predecessors in the realm of the useful, who have given us the telephone and the incandescent lamp. Permit me to remind you that I did not have, like Bell, such powerful help as the Reis telephone, which reproduced music and only needed a deft turn of an adjusting screw to repeat the human voice; or such vigorous assistance as Edison found in the incandescent lamps of King and Starr, which only needed to be made of high resistance. Not at all. I had to cut the path myself, and my hands are still sore. All the army of my opponents and detractors was ever able to drum up against me in a fanatic contest has simmered down to a short article by an Italian - Prof. Ferraris - dealing with

an abstract and meaningless idea of a rotating magnetic pole and published years after my discovery, months even after my complete disclosure of the whole practically developed system in all its essential universally adopted features. It is a publication, pessimistic and discouraging, devoid of the discoverer's virility and force, devoid of results, utterly wanting in the faith and devotion of the inventor, a defective and belated record of a good but feeble man whose only response to my whole-souled brother greeting was a plaintive cry of priority - a sad contrast to the strong and equanimous Schallenger, a true American engineer, who stoically bore the pain that killed him.

A fundamental discovery or original invention is always useful, but it is often more than that. There are physicists and philosophers to whom the marvelous manifestations of my rotating magnetic field, the suggestive phenomena of rotation without visible connection, the ideal beauty of my induction motor with its contactless armature, mean quite as much as the thousands of millions of dollars invested in enterprises of which it is the foundation.

And this is true of all my discoveries, inventions, and scientific results which I have since announced, for I have never invented what immediate necessity suggested, but what I found as most desirable to invent, irrespective of time. Let me tell you only of one - my "magnifying transmitter", a machine with which I have passed a current of one hundred amperes around the globe, with which I can make the whole earth loudly repeat a word spoken in the telephone, with which I can easily bridge the gulf which separates us from Mars. Do you mean to say that my transmitter is nothing more than a "useful piece of electrical apparatus"?

I do not wish to enlarge on this for obvious reasons. To be compelled by taciturn admirers to dwell on my own achievements is hurting my delicate sensibilities, but as I observe your heroic and increasing efforts in praising your paper, while your distinguished confreres maintain on its merits a stolid silence, I feel that there is, at least, one man in New York able to appreciate the incongeniality of the correspondence. Allow me to ask you just one or two questions in regard to a work which I began in 1892, inspired by a high tribute from Lord Rayleigh at the Royal Institution, most difficult labor which I have carried on for years, encouraged by the sympathetic interest and approval of Hemholtz, Lord Kelvin, and my great friends, Sir William Crookes and Sir James Dewar, ridiculed by small men whose names I have seen displayed in vulgar and deceptive advertisements. I refer to my system of wireless transmission of energy.

The principles which it involves are eternal. We are on a conducting body, insulated in space, of definite and unchangeable dimensions and properties. It will never be possible to transmit electrical energy economically through this body and its environment except by essentially the same means and methods which I have discovered, and the system is so perfect now that it admits of but little improvement. Since I have accepted as true your opinion, which I hope will not be shared by posterity, would you mind telling a reason why this advance should not stand worthily beside the discoveries of Copernicus? Will you state why it should not be ever so much more important and valuable to the progress and welfare of man?

We could still believe in the geocentric theory and yet advance virtually as we do. The work of the astronomer would suffer, for some of his deductions would rest on erroneous assumptions. But, after all, we shall never know the intimate nature of things. So long as our perceptions are accurate our logic will be true. No one can estimate to what an extent the great knowledge he conveyed has been instrumental in developing the power of our minds and furthering discovery and invention. Yet, it has left all the pressing material problems confronting us unsolved.

Now my wireless system offers practical solutions for all. The aerial navigation, which now agitates the minds, is only one of its many and obvious applications equally consequential. The waterfalls of this country alone, its greatest wealth, are adequate to satisfy the wants of humanity for thousands of years to come. Their energy can be used with the same facility to dig the Panama Canal as to operate the Siberian Railway or to irrigate and fertilize the Sahara. The Anglo-Saxon race has a great past and present, but its real greatness is in the future, when the water power it owns or controls shall supply the necessities of the entire world.

As to universal peace - if there is nothing in the order of nature which makes war indispensable to the safe and sane progress of man, if that utopian existence is at all possible, it can be only attained through this very means, for all international friction can be traced to but one cause - the immense extension of the planet. My system of wireless transmission completely annihilates distance in all departments of human activity.

If this does not appeal to you sufficiently to recognize in me a discoverer of principles, do me, at least, the justice of calling me an "inventor of some beautiful pieces of electrical apparatus."

NIKOLA TESLA

New York, June 21, 1907

New York Times

Oct. 19, 1907, p. 8, col. 5.

SLEEP FROM ELECTRICITY.

Nikola Tesla Noted Narcotic Influences of Periodic Currents in 1898.

To the Editor of The New York Times:

I have read with interest the reports in The Times of the 13th and 15th inst. referring to Prof. Leduc's discovery of causing sleep by electric means. While it is possible that he has made a distinct advance there is no novelty in the effect itself.

The narcotic influence of certain periodic currents was long ago discovered by me and has been pointed out in some of my technical publications, among which I may mention a paper on "High Frequency Oscillators for Electro Therapeutic and Other Purposes", read before the American Electro Therapeutic Association, Sept. 13, 1898. I have also shown that human tissues offer little resistance to the electric flow and suggested an absolutely painless method of electrocution by passing the currents through the brain. It is very likely that Prof. Leduc has taken advantage of the same general principles though he applies the currents in a different manner.

In one respect, however, my observations are at variance with those reported. From the special dispatch in The Times of the 13th inst. it would appear that sleep is induced the moment the currents are turned on, and that awakening follows as soon as the electrodes are withdrawn. It is, of course, impossible to tell how strong a current was employed, but the resistance of the head might have been, perhaps, 3,000 ohms, so that at thirty volts the current could have been only about 1-100 of an ampere. Now, I have passed a current of at least 5,000 times stronger through my head and did not lose consciousness, but I invariably fell into a lethargic sleep some time after. This fact impresses me with certain arguments of

Prof. Barker of Columbia University in your issue of Sept. 15.

I have always been convinced that electric anaesthesia will become practical, but the application of currents to the brain is so delicate and dangerous an operation that the new method will require long and careful experimentation before it can be used with certitude.

NIKOLA TESLA

New York, Oct. 16, 1907.

New York Times

Oct. 22, 1907, p. 8, col. 6.

POSSIBILITIES OF "WIRELESS"

Nikola Tesla Says Distance Forms No Obstacle to Transmission of Energy.

To the Editor of The New York Times:

In your issue of the 19th inst. Edison makes statements which cannot fail to create erroneous impressions.

There is a vast difference between primitive Hertzwave signalling, practicable to but a few miles, and the great art of wireless transmission of energy, which enables an expert to transmit, to any distance, not only signals, but power in unlimited amounts, and of which the experiments across the Atlantic are a crude application. The plants are quite inefficient, unsuitable for finer work, and totally doomed to an effect less than one percent of that I attained in my test in 1899.

Edison thinks that Sir Hiram Maxim is blowing hot air. The fact is my Long Island plant will transmit almost its entire energy to the antipodes, if desired. As to Martin's communication I can only say, that I shall be able to attain a wave activity of 800,000,000 horse power and a simple calculation will show, that the inhabitants of that planet, if there be any, need not have a Lord Raleigh to detect the disturbance.

Referring to your editorial comment of even date, the question of wireless interference is puzzling only because of its novelty. The underlying principle is old, and it has presented itself for consideration in numerous forms. Just now it appears in the novel aspects of aerial navigation and wireless transmission. Every human effort must of necessity create a disturbance. What difference is there in essence, between the commotion produced by any revolutionary idea or improvement and that of a wireless transmitter? The spectre of interference has been conjured by Hertzwave or radio telegraphy in which attunement is absolutely impossible, simply because the effect diminishes rapidly with distance. But to my system of energy transmission, based on the use of impulses not sensibly diminishing with distance, perfect attunement and the higher artifice of individualization are practicable. As ever, the ghost will vanish with the wireless dawn.

NIKOLA TESLA

New York, Oct. 21, 1907.

New York Daily Tribune
Oct. 25, 1907

TESLA ON WIRELESS.

Electrical Inventor Thinks Marconi's Plants Inefficient.

To the Editor of The Tribune:

Sir: In so far as wireless art is concerned there is a vast difference between the great inventor Thomas A. Edison and myself, integrally in my favor. Mr. Edison knows little of the theory and practice of electrical vibrations; I have, in this special field, probably more experience than any of my contemporaries. That you are not as yet able to impart your wisdom by wireless telephone to some subscriber in any other part of the world, however remote, and that the presses of your valuable paper are not operated by wireless power is largely due to your own effort and those of some of your distinguished confreres of this city, and to the efficient assistance you have received from my celebrated colleagues, Thomas A. Edison and Michael Pupin, assistant consulting wireless engineers. But it was all welcome to me. Difficulty develops resource.

The transmission across the Atlantic was not made by any device of Mr. Marconi's, but by my system of wireless transmission of energy, and I have already given notice by cable to my friend Sir James DeWar and the Royal Institution of this fact. I shall also request some eminent man of science to take careful note of the whole apparatus, its mode of operation, dimensions, linear and electrical, all constants and qualitative performance, so as to make possible its exact reproduction and repetition of the experiments. This request is entirely impersonal. I am a citizen of the United States, and I know that the time will come when my busy fellow citizens, too absorbed in commercial pursuits to think of posterity, will honor my memory. A measurement of the time interval taken in the passage of the signal necessary to the full and positive demonstration will show that the current crosses the ocean with a mean speed of 625,000 miles a second.

The Marconi plants are inefficient, and do not lend themselves to the practice of two discoveries of mine, the "art of individualization", that makes the message non-interfering and non-interferable, and the "stationary waves", which annihilate distance absolutely and make the whole earth equivalent to a conductor devoid of resistance. Were it not for this deficiency, the number of words per minute could be increased at will by "individualizing".

You have already commented upon this advance in terms which have caused me no small astonishment, in view of your normal attitude. The underlying principle is to combine a number of vibrations, preferably slightly displaced, to reduce further the danger of interference, active and passive, and to make the operation of the receiver dependent on the co-operative effect of a number of attuned elements. Just to illustrate what can be done, suppose that only four vibrations were isolated on each transmitter. Let those on one side be respectively a, b, c, and d. Then the following individualized lines would be ab, ac, ad, bc, bd, cd, abc, abd, acd, bcd and abcd. The same article on the other side will give similar combinations, and both together twenty-two lines, which can be simultaneously operated. To transmit one thousand words a minute, only forty-six words on each combination are necessary. If the plants were suitable, not ten years, as Edison thinks, but ten hours would be necessary to put this improvement into practice. To do this Marconi would have to construct the plants, and it will then be observed that the indefatigable Italian has departed from universal engineering customs for the fourth time.

NIKOLA TESLA
New York, Oct. 24, 1907

New York Times

Dec. 20, 1907, p. 4, col. 4.

MY APPARATUS, SAYS TESLA.

Confident, However, That Wireless Telephony is Entirely Possible.

To the Editor of the New York Times:

I have read with great interest the report in your issue of to-day that the Danish engineer, Waldemar Poulson, the inventor of the interesting device known as the "telegraphone", has succeeded in transmitting accurately wireless telephonic messages over a distance of 240 miles.

I have looked up the description of the apparatus he has employed in the experiment and find that it comprises:

(1) My grounded resonant transmitting circuit; (2) my inductive exciter; (3) the so-called "Tesla transformer"; (4) my inductive coils for raising the tension on the condenser; (5) my entire apparatus for producing undamped or continuous oscillations; (6) my concatenated tuned transforming circuits; (7) my grounded resonant receiving transformer; (8) my secondary receiving transformer. I note other improvements of mine, but those mentioned will be sufficient to show that Denmark is a land of easy invention.

The claim that transatlantic wireless telephone service will soon be established by these means is a modest one. To my system distance has absolutely no significance. My own wireless plant will transmit speech across the Pacific with the same precision and accuracy as across the table.

Nikola Tesla

New York, Dec. 19, 1907

WIRELESS TELEGRAPHY & TELEPHONY

By Walter W. Massie & Charles R. Underhill, 1908, pp. 67-71.

THE FUTURE OF THE WIRELESS ART

Mr. Nikola Tesla, in a recent interview by the authors, as to the future of the Wireless Art, volunteered the following statement which is herewith produced in his own words.

"A mass in movement resists change of direction. So does the world oppose a new idea. It takes time to make up the minds to its value and importance. Ignorance, prejudice and inertia of the old retard its early progress. It is discredited by insincere exponents and selfish exploiters. It is attacked and condemned by its enemies. Eventually, though, all barriers are thrown down, and it spreads like fire. This will also prove true of the wireless art.

"The practical applications of this revolutionary principle have only begun. So far they have been confined to the use of oscillations which are quickly damped out in their passage through the medium. Still, even this has commanded universal attention. What will be achieved by waves which do not diminish with distance, baffles comprehension.

"It is difficult for a layman to grasp how an electric current can be propagated to distances of thousands of miles without diminution of intention. But it is simple after all. Distance is only a relative conception, a reflection in the mind of

physical limitation. A view of electrical phenomena must be free of this delusive impression. However surprising, it is a fact that a sphere of the size of a little marble offers a greater impediment to the passage of a current than the whole earth. Every experiment, then, which can be performed with such a small sphere can likewise be carried out, and much more perfectly, with the immense globe on which we live. This is not merely a theory, but a truth established in numerous and carefully conducted experiments. When the earth is struck mechanically, as is the case in some powerful terrestrial upheaval, it vibrates like a bell, its period being measured in hours. When it is struck electrically, the charge oscillates, approximately, twelve times a second. By impressing upon it current waves of certain lengths, definitely related to its diameter, the globe is thrown into resonant vibration like a wire, stationary waves forming, the nodal and ventral regions of which can be located with mathematical precision. Owing to this fact and the spheroidal shape of the earth, numerous geodetical and other data, very accurate and of the greatest scientific and practical value, can be readily secured. Through the observation of these astonishing phenomena we shall soon be able to determine the exact diameter of the planet, its configuration and volume, the extent of its elevations and depressions, and to measure, with great precision and with nothing more than an electrical device, all terrestrial distances. In the densest fog or darkness of night, without a compass or other instruments of orientation, or a timepiece, it will be possible to guide a vessel along the shortest or orthodromic path, to instantly read the latitude and longitude, the hour, the distance from any point, and the true speed and direction of movement. By proper use of such disturbances a wave may be made to travel over the earth's surface with any velocity desired, and an electrical effect produced at any spot which can be selected at will and the geographical position of which can be closely ascertained from simple rules of trigonometry.

"This mode of conveying electrical energy to a distance is not 'wireless' in the popular sense, but a transmission through a conductor, and one which is incomparably more perfect than any artificial one. All impediments of conduction arise from confinement of the electric and magnetic fluxes to narrow channels. The globe is free of such cramping and hinderment. It is an ideal conductor because of its immensity, isolation in space, and geometrical form. Its singleness is only an apparent limitation, for by impressing upon it numerous non-interfering vibrations, the flow of energy may be directed through any number of paths which, though bodily connected, are yet perfectly distinct and separate like ever so many cables. Any apparatus, then, which can be operated through one or more wires, at distances obviously limited, can likewise be worked without artificial conductors, and with the same facility and precision, at distances without limit other than that imposed by the physical dimensions of the globe.

"It is intended to give practical demonstrations of these principles with the plant illustrated. As soon as completed, it will be possible for a business man in New York to dictate instructions, and have them instantly appear in type at his office in London or elsewhere. He will be able to call up, from his desk, and talk to any telephone subscriber on the globe, without any change whatever in the existing equipment. An inexpensive instrument, not bigger than a watch, will enable its bearer to hear anywhere, on sea or land, music or song, the speech of a political leader, the address of an eminent man of science, or the sermon of an eloquent clergyman, delivered in some other place, however distant. In the same manner any picture, character, drawing, or print can be transferred from one to another place. Millions of such instruments can be operated from but one plant of this kind. More important than all of this, however, will be the transmission of power, without wires, which will be shown on a scale large enough to carry conviction. These few indications will be sufficient to show that the wireless art offers greater possibilities than any invention or discovery heretofore made, and if the conditions are

favorable, we can expect with certitude that in the next few years wonders will be wrought by its application."

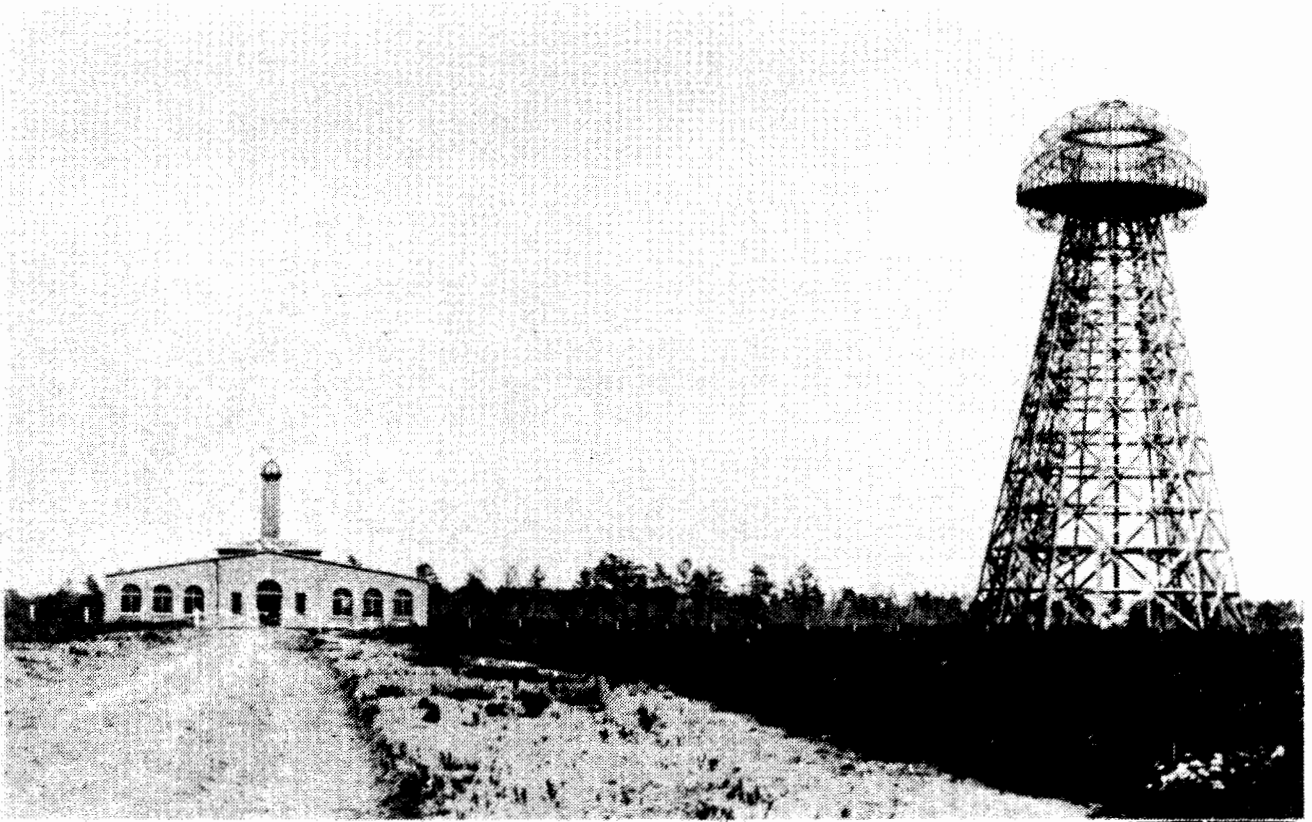

THE TESLA WIRELESS PLANT ON LONG ISLAND

N. Y. World
Jan. 5, 1908

NIKOLA TESLA'S FORECAST FOR 1908.

Aerial and Sea Navigation and Wireless Telegraphy to Make Astounding Strides.

To the Editor of The World:

A forecast - not a prophecy!

Constant and careful study of the state of things in this particular sphere enables an expert to make a forecast fairly accurate of the next state. The seemingly isolated events are to him but links of a chain. As a rule, the signs he notes are so pronounced that he can predict the changes about to take place with certitude. The performance is a mere banality as compared with the piercing view of the inspired into the distant future. This is a forecast - not a prophecy.

The coming year will be great in thought and result. It will mark the end of a number of erroneous ideas which, by their paralyzing effect on the mind, have throttled independent research and hampered progress and development in various departments of science and engineering.

The first to be dispelled is the illusion of the Hertz or electro-magnetic waves. The expert already realizes that practical wireless telegraphy and telephony are possible only by minimizing this wasteful radiation. The results recently attained in this manner with comparatively crude appliances illustrate strikingly the possibilities of the genuine art. Before the close of the year wireless transmission across the Pacific and trans-Atlantic wireless telephony may be expected with perfect confidence. The use of the wireless telephone in isolated districts will spread like fire.

The year will mark the fall of the illusionary idea that action must diminish with distance. By impressing upon the earth certain vibrations to which it responds resonantly, the whole planet is virtually reduced to the size of a little marble, thus enabling the reproduction of any kind of effect, as human speech, music, picture or character whatever, and even the transmission of power in unlimited amounts with exactly the same facility and economy at any distance, however great.

The next twelve months will witness a similar revolution of ideas regarding radio-activity. That there is no such element as radium, polonium or ronium is becoming more and more evident. These are simply deceptive appearances of a modern phlogiston. As I have stated in my early announcement of these emanations before the discovery of Mme. Curie, they are emitted more or less by all bodies, and are all of the same kind - merely effects of shattered molecules, differentiated not by the nature of substance but by size, speed and electrification.

The coming year will dispel another error which has greatly retarded progress of aerial navigation. The aeronaut will soon satisfy himself that an aeroplane proportioned according to data obtained by Langley is altogether too heavy to soar, and that such a machine, while it will have some uses, can never fly as fast as a dirigible balloon. Once this is fully recognized the expert will concentrate his efforts on the latter type, and before many months are passed it will be a familiar object in the sky.

There is abundant evidence that distinct improvements will be made in ship propulsion. The numerous theories are giving place to the view that what propels the vessel is a reactive jet; hence the propeller is doomed in efficiency at high speed. A new principle will be introduced.

The World is invited to test the accuracy of this forecast at the close of the year.

NIKOLA TESLA

New York Times

April 21, 1908, p. 5, col. 6.

MR. TESLA'S VISION

How the Electrician's Lamp of Aladdin May Construct New Worlds.

To the Editor of the New York Times:

From a report in your issue of March 11, which escaped my attention, I notice that some remarks I made on the occasion referred to have been misunderstood. Allow me to make a correction.

When I spoke of future warfare I meant that it should be conducted by direct application of electrical waves without the use of aerial engines or other implements of destruction. This means, as I pointed out, would be ideal, for not only would the energy of war require no effort for the maintenance of its potentiality, but it would be productive in times of peace. This is not a dream. Even now wireless power plants could be constructed by which any region of the globe might be rendered uninhabitable without subjecting the population of other parts to serious danger or inconvenience.

What I said in regard to the greatest achievement of the man of science whose mind is bent upon the mastery of the physical universe, was nothing more than what I stated in one of my unpublished addresses, from which I quote: "According to an adopted theory, every ponderable atom is differentiated from a tenuous fluid, filling all space merely by spinning motion, as a whirl of water in a calm lake. By being set in movement this fluid, the ether, becomes gross matter. Its movement arrested, the primary substance reverts to its normal state. It appears, then, possible for man through harnessed energy of the medium and suitable agencies for starting and stopping ether whirls to cause matter to form and disappear. At his command, almost without effort on his part, old worlds would vanish and new ones would spring into being. He could alter the size of this planet, control its seasons, adjust its distance from the sun, guide it on its eternal journey along any path he might choose, through the depths of the universe. He could make planets collide and produce his suns and stars, his heat and light; he could originate life in all its infinite forms. To cause at will the birth and death of matter would be man's grandest deed, which would give him the mastery of physical creation, make him fulfill his ultimate destiny."

Nothing could be further from my thought than to call wireless telephony around the world "the greatest achievement of humanity" as reported. This is a feat which, however stupifying, can be readily performed by any expert. I have myself constructed a plant for this very purpose. The wireless wonders are only seeming, not results of exceptional skill, as popularly believed. The truth is the electrician has been put in possession of a veritable lamp of Aladdin. All he has to do is to rub it. Now, to rub the lamp of Aladdin is no achievement.

If you are desirous of hastening the accomplishment of still greater and further-reaching wonders you can do no better than by emphatically opposing any measure tending to interfere with the free commercial exploitation of water power and the wireless art. So absolutely does human progress depend on the development of these that the smallest impediment, particularly through the legislative bodies of this country, may set back civilization and the cause of peace for centuries.

Nikola Tesla

New York, April 19, 1908

New York Times

June 8, 1908 p. 6, col. 5

LITTLE AEROPLANE PROGRESS

So Says Nikola Tesla - But He is Working on One of His Own.

To the Editor of the New York Times:

It was not a little amusing to read a short time ago how the "great secret" of the aeroplane was revealed. By surrounding that old device with an atmosphere of mystery one gives life and interest to the report; but the plain fact is that all forms of aerial apparatus are well known to engineers, and can be designed for any specific duty without previous trials and with a fair degree of accuracy. The flying machine has materialized - not through leaps and bounds of invention, but by progress slow and imperceptible, not through original individual effort, but by a combination of the same forces which brought forth the automobile, and the motor-boat. It is due to the enterprise of the steel, oil, electrical, and other concerns, who have been instrumental in the improvement of materials of construction and in the production of high-power fuels, as well as to the untiring labors of the army of skilled but unknown mechanics, who have been for years perfecting the internal combustion engine.

There is no salient difference between the dirigible balloon of Renard and Krebs of thirty years ago and that of Santos Dumont with which the bold Brazilian performed his feats. The Langley and Maxim aerodromes, which did not soar, were in my opinion better pieces of mechanism than their very latest imitations. The powerful gasoline motor which has since come into existence is practically the only radical improvement.

So far, however, only the self-propelled machine or aerial automobile is in sight. While the dirigible balloon is rapidly nearing the commercial stage, nothing practical has as yet been achieved with the heavier-than-air machine. Without exception the apparatus is flimsy and unreliable. The motor, too light for its power, gives out after a few minutes run; the propeller blades fly off; the rudder is broken, and, after a series of such familiar mishaps, there comes the inevitable and general smash-up. In strong contrast with these unnecessarily hazardous trials are the serious and dignified efforts of Count Zeppelin, who is building a real flying machine, safe and reliable, to carry a dozen men and provisions over distances of thousands of miles, and with a speed far in excess of those obtained with aeroplanes.

The limits of improvement in the flying machine, propelled by its own power, whether light or heavy, are already clearly defined. We know very closely what we may expect from the ultimate perfection of the internal combustion engine, the resistances which are to be overcome, and the limitations of the screw propeller. The margin is not very great. For many reasons the wireless transmission of power is the only perfect and lasting solution to reach very high speeds.

In this respect many experts are mistaken. The popular belief that because the air has only one-hundredth the density of water, enormous velocities should be practicable. But it is not so. It should be borne in mind that the air is one hundred times more viscous than water, and because of this alone the speed of the flying machine could not be much in excess of a properly designed aqueous craft.

The aeroplanes of the Langley type, such as was used by Farman and others with some success, will hardly ever prove a practical aerial machine, because no provision is made for maintaining it in the air in a downward current. This and the perfect balance independently of the navigator's control is absolutely essential to the

success of the heavier-than-air machine. These two improvements I am myself endeavoring to embody in a machine of my own design.

Nikola Tesla
New York, June 6, 1908

New York Times
Sept. 15, 1908

TESLA ON AEROPLANES.

Says Successful Heavier-Than-Air Flier Will be Different.

To the Editor of The New York Times:

The chronicler of current events is only too apt to lose sight of the true perspective and real significance of the phases of progress he records. Naturally enough, his opinions on subjects out of the sphere of his special training are frequently defective, but this is inseparable from the very idea of journalism. If an editor were to project himself into the future and view the happenings of the present or of the past in their proper relations he would make a dismal failure of his paper.

The comments upon the latest performances with aeroplanes afford interesting examples in this respect. What is there so very different between a man flying half an hour and another, using a more powerful machine, an hour, or two, or three? To be sure, in one instance the supporting planes are larger and the gasoline tank bigger, but there is nothing revolutionary in these departures. No one can deny the merit of the accomplishments. The feats are certainly remarkable and of great educational value.

The majority of human beings are unreceptive to novel ideas. The practical demonstrator comes with forceful arguments which enlighten and convince. But they are nothing more than obvious consequences of what has preceded, steps in advance which, taken singly, are of no particular importance, but which, in their totality, make up the conquest of the world by the new idea. If any one stands out more strongly than the other it is merely because it chances to occur at the psychological moment, when incredulity and doubt are giving way to confidence and expectancy. Such work is often brilliant, never great, as some would make believe. To be great it must be original. Of such feature it is absolutely devoid.

Place any of the later aeroplanes beside that of Langley, their prototype, and you will not find as much as one decided improvement. There are the same old propellers, the same old inclined planes, rudders, and vanes - not a single notable difference. Some have tried to hide their "discoveries." It is like the hiding of an ostrich who buries his head in the sand. Half a dozen aeronauts have been in turn hailed as conquerors and kings of the air. It would have been much more appropriate to greet John D. Rockefeller as such. But for the abundant supply of high-grade fuel we would still have to wait for an engine capable of supporting not only itself but several times its own weight against gravity.

The capabilities of the Langley aerodrome have been most strikingly illustrated. Notwithstanding this, it is not a practical machine. It has a low efficiency of propulsion, and the starting, balancing, and alighting are attended with difficulties. The chief defect, however, is that it is doomed if it should encounter a downward gust of wind. The helicopter is in these respects much preferable, but is objectionable for other reasons. The successful heavier-than-air flier will be based on principles radically novel and will meet all requirements. It will soon

materialize, and when it does it will give an impetus to manufacture and commerce such as was never witnessed before, provided only that the Governments do not resort to the methods of the Spanish Inquisition, which have already proved so disastrous to the wireless art, the ideal means for making man absolute master of the air.

Ni(c)ola Tesla
New York, Sept. 13, 1908

New York Times
May 23, 1909, p. 10, col. 6,7.

HOW TO SIGNAL MARS

Wireless the Only Way Now, Says Nikola Tesla - Mirror Plans Not Practicable.

To the Editor of the New York Times:

Of all the evidence of narrow mindedness and folly, I know of no greater than the stupid belief that this little planet is singled out to be the seat of life, and that all other heavenly bodies are fiery masses or lumps of ice. Most certainly, some planets are not inhabited, but others are, and among these there must exist life under all conditions and phases of development.

In the solar system Venus, the Earth, and Mars represent respectively, youth, full growth, and old age. Venus, with its mountains rising dozens of miles into the atmosphere, is probably as yet unfitted for such existence as ours, but Mars must have passed through all terrestrial states and conditions.

Civilized existence rests on the development of the mechanical arts. The force of gravitation on Mars is only two-thirds of that on earth, hence all mechanical problems must have been much easier of solution. This is even more so of the electrical. The planet being much smaller, the contact between individuals and the mutual exchange of ideas must have been much quicker, and there are many other reasons why intellectual life should have been on that planet, phenomenal in its evolution.

To be sure, we have no absolute proof that Mars is inhabited. The straightness of the canals, which has been held out as a convincing indication to this effect, is not at all such. We can conclude with mathematical certitude that as a planet grows older and the mountains are leveled down, ultimately every river must flow in a geodetically straight line. Such straightening is already noticeable in some rivers of the earth.

Believes Mars Signaled Him.

But the whole arrangement of the so-called waterways, as pictured by Lowell, would seem to have been designed. Personally I base my faith on the feeble planetary electrical disturbances which I discovered in the summer of 1899, and which, according to my investigations, could not have originated from the sun, the moon, or Venus. Further study since has satisfied me that they must have emanated from Mars. All doubt in this regard will be soon dispelled.

To bring forth arguments why an attempt should be made to establish interplanetary communication would be a useless and ungrateful undertaking. If we had no other reason, it would be justified by the universal interest which it will command, and by the inspiring hopes and expectations to which it would give rise. I shall rather concentrate my efforts upon the examination of the plans proposed and the

description of a method by which this seemingly impossible task can be readily accomplished.

The scheme of signaling by rays of light is old, and has been often discussed, perhaps, more by that eloquent and picturesque Frenchman, Camille Flammarion, than anybody else. Quite recently Prof. W. H. Pickering, as stated in several issues of the New York Times, has made a suggestion which deserves careful examination.

The total solar radiation falling on a terrestrial area perpendicular to the rays amounts to eighty-three foot pounds per square foot per second. This activity measured by the adopted standard is a little over fifteen one-thousandth of a horse-power. But only about 10 per cent of this whole is due to waves of light. These, however, are of widely different lengths, making it impossible to use all in the best advantage, and there are specific losses unavoidable in the use of mirrors, so that the power of sunlight reflected from them can scarcely exceed 5.5 foot pounds per square foot per second, or about one one-hundredth of a horse-power.

A Giant Reflector Needed.

In view of this small activity, a reflecting surface of at least one-quarter million square feet should be provided for the experiment. This area, of course, should be circular to insure the greatest efficiency, and, with due regard to economy, it should be made up of mirrors rather small, such as to meet best the requirements of cheap manufacture.

The idea has been advanced by some experts that a small reflector would be as efficient as a large one. This is true in a degree, but holds good only in heliographic transmission to small distances when the area covered by the reflected beam is not vastly in excess of that of the mirror. In signaling to Mars, the effect would be exactly proportionate to the aggregate surface of the reflections. With an area of one-quarter million square feet the activity of the reflected sunlight, at the origin would be about 2,500 horse-power.

It scarcely need be stated that these mirrors would have to be ground and polished most carefully. To use ordinary commercial plates, as has been suggested, would be entirely out of the question, for at such an immense distance the imperfections of surface would fatally interfere with efficiency. Furthermore, expensive clock work would have to be employed to rotate the reflectors in the manner of heliostats, and provision would have to be made for protection against destructive atmospheric influence. It is extremely doubtful that so formidable an array of apparatus could be produced for \$10,000,000, but this is a consideration of minor importance to this argument.

Sight Unlimited in a Vacuum.

If the reflected rays were parallel and the heavenly bodies devoid of atmospheres, nothing would be simpler than signaling to Mars, for it is a truth accepted by physicists that a bundle of parallel rays, in vacuo, would illuminate an area with the same intensity, whether it be near or infinitely remote. In other words, there is no sensible loss in the transportation of radiant energy through interplanetary or vacuum space. This being the case, could we but penetrate the prison wall of the atmosphere, we could clearly perceive the smallest object on the most distant star, so inconceivably tenuous, frictionless, rigid, and elastic is the medium pervading the universe.

The sun's rays are usually considered to be parallel, and are virtually so through a short trajectory, because of the immense distance of the luminary. But the radiations, coming from a distance of 93,000,000 miles, emanate from a sphere 865,000 miles in diameter, and, consequently, most of them will fall on the mirrors at an angle less than 90 degrees, with the result of causing a corresponding

divergence of the reflected rays. Owing to the equality of the angles of incidence and reflection, it follows that if Mars were at half the sun's distance, the rays reaching the planet would cover an area of about one-quarter of that of the solar disc, or in round numbers, 147,000,000,000 square miles, which is nearly 16,400,000,000 times larger than that of the mirrors. This means that the intensity of the radiation received on Mars would be just that many times smaller.

To convey a definite idea, it may be stated that the light we get from the moon is 600,000 times feebler than that of the sun. Accordingly, even under these purely theoretical conditions the Pickering apparatus could do no more than produce an illumination 27,400,000 times feebler than that of the full moon, or 1,000 times weaker than that of Venus.

Atmosphere the Chief Obstacle.

The preceding is based on the assumption that there is nothing in the path of the reflected rays except the tenuous medium filling all space. But the planets have atmospheres which absorb and refract. We see remote objects less distinctly, we perceive stars long after they have fallen below the horizon. This is due to absorption and refraction of the rays passing through the air. While these effects cannot be exactly estimated it is certain that the atmosphere is the chief impediment to the study of the heavens.

By locating our observatories one mile above sea level the quantity of matter which the rays have to traverse on their way to the planet is reduced to one-third. But, as the air becomes less dense, there is comparatively little gain to be derived from greater elevation. What chance would there be that the reflected rays, reduced to an intensity far below that estimated above, would produce a visible signal on Mars? Though I do not deny this possibility, all evidence points to the contrary.

Lowell, a trained and restless observer, who has made the study of Mars his specialty, and is working under ideal conditions, has been so far unable to perceive a light effect of the magnitude such as the proposed signaling apparatus might produce there. Phobos, the smaller of the two satellites of Mars - from seven to 10 miles in diameter - can only be seen at short intervals when the planet is in opposition. The satellite presents to us an area of approximately fifty square miles, reflecting sunlight at least as well as ordinary earth, which has little over one-twelfth of the power of a mirror.

Stated otherwise, an equivalent effect at that distance would be produced by mirrors covering four square miles, which means two square miles of the same reflectors if located on earth, as it receives sunlight of twice the intensity. Now this is an area 222 times larger than that of the ten million dollar reflector, and yet Phobos is hardly perceptible. It is true that the observation of the satellite is rendered difficult by the glare of its mother planet. But this is offset by the fact that it is in vacuum and that its rays suffer little diminution through absorption and refraction of the earth's atmosphere.

Mirror Signal Impossible Now.

What has been stated is thought sufficient to convince the reader that there is little to be expected from the plan under discussion. The idea naturally presents itself that mirrors might be manufactured which will reflect sunlight in parallel beams. For the time being this is a task beyond human power, but no one can set a limit to the future achievement of man.

Still more ineffective would be the attempt of signaling in the manner proposed by Dr. William R. Brooks and others, by artificial light, as the electric arc. In order to obtain a reflected light activity of 2,500 horsepower it would be necessary to install a power plant of not less than 75,000 horsepower, which, with its

turbines, dynamos, parabolic reflectors and other paraphernalia, would probably cost more than \$10,000,000. While this method would permit operation at favorable times, when the earth is nearer to, and has its dark side turned toward Mars, it has the disadvantage of involving the use of reflected rays necessarily more divergent than those of the sun, it being impossible to construct mirrors of the required perfection and without their use the rays would be scattered to such an extent that the effect would be much smaller.

Reflecting surfaces of great extent can be had readily. Prof. R. W. Wood makes the odd suggestion of using the white alkali desert of the southwest for the purpose. Prof. E. Doolittle advises the employment of large geometric figures. In my opinion none of these suggestions is feasible. The trouble is, that the earth itself is a reflector, not efficient, it is true, but what it lacks in this respect is more than made up by the immensity of its area. To convey a perceptible signal in this manner it might require as much as 100 square miles reflecting surface.

Wireless Offers the Best Plan.

But there is one method of putting ourselves in touch with other planets. Though not easy of execution, it is simple in principle. A circuit properly designed and arranged is connected with one of its ends to an insulated terminal at some height and with the other to earth. Inductively linked with it is another circuit in which electrical oscillations of great intensity are set up by means now familiar to electricians. This combination of apparatus is known as my wireless transmitter.

By careful attunement of the circuits the expert can produce a vibration of extraordinary power, but when certain artifices, which I have not yet described are resorted to the oscillation reaches transcending intensity. By this means, as told in my published technical records, I have passed a powerful current around the globe and attained activities of many millions of horsepower. Assuming only a rate of 15,000,000, readily obtainable, it is 6,000 times more than that produced by the Pickering mirrors.

But, my method has other and still greater advantages. By its employment the electrician on Mars, instead of utilizing the energy received by a few thousand square feet of area, as in a parabolic reflector, is enabled to concentrate in his instrument the energy received by dozens of square miles, thus multiplying the effect many thousands of times. Nor is this all. By proper methods and devices he can magnify the received effect as many times again.

It is evident, then, that in my experiments in 1899 and 1900 I have already produced disturbances on Mars incomparably more powerful than could be attained by any light reflectors, however large.

Electrical science is now so far advanced that our ability of flashing a signal to a planet is experimentally demonstrated. The question is, when will humanity witness that great triumph. This is readily answered. The moment we obtain absolute evidences that an intelligent effort is being made in some other world to this effect, interplanetary transmission of intelligence can be considered an accomplished fact. A primitive understanding can be reached quickly without difficulty. A complete exchange of ideas is a greater problem, but susceptible of solution.

Nikola Tesla

Denver Rocky Mountain News

Jan. 16, 1910, Section 2, p. 4, cols. 4,5.

WHAT SCIENCE MAY ACHIEVE THIS YEAR

New Mechanical Principle for Conservation of Energy

The spread of civilization may be likened to that of fire: First, a feeble spark, next a flickering flame, then a mighty blaze, ever increasing in speed and power. We are now in this last phase of development.

Human activity has become so widespread and intense that years count as centuries of progress. There is no more groping in the dark or accidentally stumbling upon discoveries. The results follow one another like the links of a chain. Such is the force of the accumulated knowledge and the insight into natural laws and phenomena that future events are clearly projected before our vision. To foretell what is coming would be no more than to draw logical conclusions, were it not for the difficulty in accurately fixing the time of accomplishment.

The practical success of an idea, irrespective of its inherent merit, is dependent on the attitude of the contemporaries. If timely it is quickly adopted; if not, it is apt to fare like a sprout lured out of the ground by warm sunshine, only to be injured and retarded in its growth by the succeeding frost. Another determining factor is the amount of change involved in its introduction. To meet with instant success an invention or discovery must come not only as a rational, but a welcome solution. The year 1910 will mark the advent of such an idea. It is a new mechanical principle.

Since the time of Archimedes certain elementary devices were known, which were finally reduced to two, the lever and the inclined plane. Another element is to be added to these, which will give rise to new conceptions and profoundly affect both the practical and theoretical science of mechanics.

This novel principle is capable of embodiment in all kinds of machinery. It will revolutionize the propulsion apparatus on vessels, the locomotive, passenger car and the automobile. It will give us a practical flying machine entirely different from those made heretofore in operation and control, swift, small and compact and so safe that a girl will be able to fly in it to school without the governess. But the greatest value of this improvement will be in its application in a field virtually unexplored and so vast that it will take decades before the ground is broken. It is the field of waste.

We build but to tear down. Most of our work and resource is squandered. Our onward march is marked by devastation. Everywhere there is an appalling loss of time, effort and life. A cheerless view, but true. A single example out of many will suffice for illustration.

The energy necessary to our comfort and safe existence is largely derived from coal. In this country alone nearly one million tons of the life-sustaining material are daily extracted from the bowels of the earth with pain and sacrifice. This is about seven hundred tons per minute, representing a theoretical activity of, say, four hundred and fifty-million horsepower. But only a small percentage of this is usefully applied.

In heating, most of the precious energy escapes through the flue. The chimneys of New York City puff out into the air several million horsepower. In the use of coal for power purposes, we hardly capture more than 10 percent. The exhaust of engines carries off more energy than obtained from live steam.

In many modern plants the power has been actually doubled by obviating this waste.

but the machinery employed is cumbersome and expensive. The manufacture of light is in a barbarous state of imperfection, and this may also be said of many industrial processes. Consider just one case, the manufacture of iron and steel.

America produces approximately 30,000,000 tons of pig iron per year. Each ton of iron requires about one and a half tons of coal, hence, in providing the iron market, 70,000,000 tons of coal per annum, or 133 tons per minute, are consumed. In the manufacture of coke a ton of coal yields, roughly, 10,000 cubic feet of gas of a mean heating capacity of 600 heat units per cubic foot.

Bearing in mind that 133 tons are used per minute, the total heat units developed in that time would be 798,000,000, the mechanical equivalent of which is about 19,000,000 horsepower. By the use of the new principle 7,000,000 horsepower might be rendered available. A furnace of 200 tons produces approximately 17,000 cubic feet of gas per minute of heat value of 100 units, corresponding to a theoretical performance of 40,000 horsepower, of which not less than 13,000 might be utilized in the improved apparatus referred to. The power derived by this method from all blast furnaces in the United States would be considerably above 5,000,000 horsepower.

The preceding figures, which are conservative, show that it would be possible to obtain 12,000,000 horsepower merely from the waste gasses in the iron and steel manufacture. The value of this power, fairly estimated, is \$180,000,000 per annum, and it must be made worth much more by systematic exploitation.

A part of the power could be advantageously employed for operating the blowers, rollers and other indispensable machinery and supplying electricity for smelting, steel making and other purposes. The bulk might be used in the manufacture of nitrates, aluminum, carbides and ice. The production of nitrates would be particularly valuable from the point of view of national economy. Assuming that 5,000,000 horsepower were apportioned for that purpose, the annual yield would be not less than 10,000,000 tons of concentrated nitric compound, adequate to fertilizing 40,000,000 acres of land. A great encouragement would be given to agriculture and the condition of the steel and iron workers ameliorated by offering to them a fertilizer at a reduced rate, thus enabling them to cultivate their farms with exceptional profit. Other conveniences and necessities, as light, power, ice and ozonized water could be similarly offered and numerous other improvements, both to the advantage of capital and labor, carried out.

To appreciate the above it should be borne in mind that the iron and steel industry is one of the best regulated in the world. In many other fields the waste is even greater. For example, in the operation of steam railroads, not less than 98 per cent of the total energy of coal burned is lost. An enormous saving could be effected by replacing the present apparatus with new gas turbines and other improved devices for transmitting and storing mechanical energy. A study of this subject will convince that for the time being, at least, there is more opportunity for invention in the utilization of waste than in the opening up of new resources.

N. Tesla

Modern Electrics
May, 1912 p. 126

MR. TESLA ON THE FUTURE

On Tesla Day, at the Northwest Electric Show, held at Minneapolis, Minn., March 16th to 23rd, Mr. Tesla sent, through Archbishop Ireland, the following message to the people of the Twin Cities and the Northwest:

New York, N. Y., March 18, 1912. His Grace, The Most Reverend Archbishop Ireland:

I bespeak your Grace's far-famed eloquence in voicing sentiments and ideas to which I can give but feeble expression. May the exposition prove a success befitting the cities of magical growth, the courage and energy of western enterprise, a credit to its organization, a lasting benefit to the communities and the world through its lessons and stimulating influence as a bewildering, unforgettable record of the triumphant progress of the art. Great as are the past achievements, the future holds out more glorious promise. We are getting an insight into the essence of things; our means and methods are being refined, a new and specialized race is developing with knowledge deep and precise, with greater powers and keener perceptions. Mysterious as ever before, nature yields her precious secrets more readily and the spirit of man asserts its mastery over the physical universe. The day is not distant when the very planet which gave him birth will tremble at the sound of his voice; he will make the sun his slave, harness the inexhaustible and terribly intense energy of microcosmic movement; cause atoms to combine in predetermined forms; he will draw the mighty ocean from its bed, transport it through the air and create lakes and rivers at will; he will command the wild elements; he will push on and on from great to greater deeds until with his intelligence and force he will reach out to spheres beyond the terrestrial.

I am your Grace's most obedient servant.

Nikola Tesla

Electrical Review and Western Electrician
July 6, 1912

THE DISTURBING INFLUENCE OF SOLAR RADIATION ON THE WIRELESS TRANSMISSION OF ENERGY.

By Nikola Tesla

When Heinrich Hertz announced the results of his famous experiments in confirmation of the Maxwellian electromagnetic theory of light, the scientific mind at once leaped to the conclusion that the newly discovered dark rays might be used as a means for transmitting intelligible messages through space. It was an obvious inference, for heliography, or signalling by beams of light, was a well recognized wireless art. There was no departure in principle, but the actual demonstration of a cherished scientific idea surrounded the novel suggestion with a nimbus of originality and atmosphere of potent achievement. I also caught the fire of enthusiasm but was not long deceived in regard to the practical possibilities of this method of conveying intelligence.

Granted even that all difficulties were successfully overcome, the field of application was manifestly circumscribed. Heliographic signals had been flashed to a distance of 200 miles, but to produce Hertzian rays of such penetrating power as those of light appeared next to impossible, the frequencies obtainable through electrical discharges being necessarily of a much lower order. The rectilinear propagation

would limit the action on the receiver to the extent of the horizon and entail interference of obstacles in a straight line joining the stations. The transmission would be subject to the caprices of the air and, chief of all drawbacks, the intensity of disturbances of this character would rapidly diminish with distance.

But a few tests with apparatus, far ahead of the art of that time, satisfied me that the solution lay in a different direction, and after a careful study of the problem I evolved a new plan which was fully described in my addresses before the Franklin Institute and National Electric Light Association in February and March, 1893. It was an extension of the transmission through a single wire without return, the practicability of which I had already demonstrated. If my ideas were rational, distance was of no consequence and energy could be conveyed from one to any point of the globe, and in any desired amount. The task was begun under the inspiration of these great possibilities.

While scientific investigation had laid bare all the essential facts relating to Hertz-wave telegraphy, little knowledge was available bearing on the system proposed by me. The very first requirement, of course, was the production of powerful electrical vibrations. To impart these to the earth in an efficient manner, to construct proper receiving apparatus, and develop other technical details could be confidently undertaken. But the all important question was, how would the planet be affected by the oscillations impressed upon it? Would not the capacity of the terrestrial system, composed of the earth and its conducting envelope, be too great? As to this, the theoretical prospect was for a long time discouraging. I found that currents of high frequency and potential, such as had to be necessarily employed for the purpose, passed freely through air moderately rarefied. Judging from these experiences, the dielectric stratum separating the two conducting spherical surfaces could be scarcely more than 20 kilometers thick and, consequently, the capacity would be over 220,000 microfarads, altogether too great to permit economic transmission of power to distances of commercial importance. Another observation was that these currents cause considerable loss of energy in the air around the wire. That such waste might also occur in the earth's atmosphere was but a logical inference.

A number of years passed in efforts to improve the apparatus and to study the electrical phenomena produced. Finally my labors were rewarded and the truth was positively established; the globe did not act like a conductor of immense capacity and the loss of energy, due to absorption in the air, was insignificant. The exact mode of propagation of the currents from the source and the laws governing the electrical movement had still to be ascertained. Until this was accomplished the new art could not be placed on the plane of scientific engineering. One could bridge the greatest distance by sheer force, there being virtually no limit to the intensity of the vibrations developed by such a transmitter, but the installment of economic plants and the predetermination of the effects, as required in most practical applications, would be impossible.

Such was the state of things in 1899 when I discovered a new difficulty which I had never thought of before. It was an obstacle which could not be overcome by any improvement devised by man and of such nature as to fill me with apprehension that transmission of power without wires might never be quite practicable. I think it useful, in the present phase of development, to acquaint the profession with my investigations.

It is a well known fact that the action on a wireless receiver is appreciably weaker during the day than at night and this is attributed to the effect of sunlight on the elevated aerials, an explanation naturally suggested through an early observation of Heinrich Hertz. Another theory, ingenious but rather fine-spun, is that some of the energy of the waves is absorbed by ions or electrons, freed in sunlight and caused to move in the direction of propagation. THE ELECTRICAL REVIEW AND WESTERN ELECTRICIAN of June 1, 1912, contains a report of a test, during the

recent solar eclipse, between the station of the Royal Dock Yard in Copenhagen and the Blaavandshuk station on the coast of Jutland, in which it was demonstrated that the signals in that region became more distinct and reliable when the sunlight was partially cut off by the moon. The object of this communication is to show that in all the instances reported the weakening of the impulses was due to an entirely different cause.

It is indispensable to first dispel a few errors under which electricians have labored for years, owing to the tremendous momentum imparted to the scientific mind through the work of Hertz which has hampered independent thought and experiment. To facilitate understanding, attention is called to the annexed diagrams in which Fig. 1 and Fig. 2 represent, respectively, the well known arrangements of circuits in the Hertz-wave system and my own. In the former the transmitting and receiving conductors are separated from the ground through spark gaps, choking coils, and high resistances. This is necessary, as a ground connection greatly reduces the intensity of the radiation by cutting off half of the oscillator and also by increasing the length of the waves from 40 to 100 percent, according to the distribution of capacity and inductance. In the system devised by me a connection to earth, either directly or through a condenser is essential. The receiver, in the first case, is affected only by rays transmitted through the air, conduction being excluded; in the latter instance there is no appreciable radiation and the receiver is energized through the earth while an equivalent electrical displacement occurs in the atmosphere.

Now, an error which should be the focus of investigation for experts is, that in the arrangement shown in Fig. 1 the Hertzian effect has been gradually reduced through the lowering of frequency, so as to be negligible when the usual wavelengths are employed. That the energy is transmitted chiefly, if not wholly, by conduction can be demonstrated in a number of ways. One is to replace the vertical transmitting wire by a horizontal one of the same effective capacity, when it will be found that the action on the receiver is as before. Another evidence is afforded by quantitative measurement which proves that the energy received does not diminish with the square of the distance, as it should, since the Hertzian radiation propagates in a hemisphere. One more experiment in support of this view may be suggested. When transmission through the ground is prevented or impeded, as by severing the connection or otherwise, the receiver fails to respond, at least when the distance is considerable. The plain fact is that the Hertz waves emitted from the aerial are just as much of a loss of power as the short radiations of heat due to frictional waste in the wire. It has been contended that radiation and conduction might both be utilized in actuating the receiver, but this view is untenable in the light of my discovery of the wonderful law governing the movement of electricity through the globe, which may be conveniently expressed by the statement that the projection of the wave-lengths (measured along the surface) on the earth's diameter or axis of symmetry of movement are all equal. Since the surfaces of the zones so defined are the same the law can also be expressed by stating *that the current sweeps in equal times over equal terrestrial areas.* (See among others "Handbook of Wireless Telegraph," by James Erskine-Murray.) Thus the velocity propagation through the superficial layers is variable, dependent on the distance from the transmitter, the mean value being $\pi/2$ times the velocity of light, while the ideal flow along the axis of propagation takes place with a speed of approximately 300,000 kilometers per second.

To illustrate, the current from a transmitter situated at the Atlantic Coast will traverse that ocean - a distance of 4,800 kilometers - in less than 0.006 second with an average speed of 800,000 kilometers. If the signalling were done by Hertz waves the time required would be 0.016 second.

Bearing, then, in mind, that the receiver is operated simply by currents

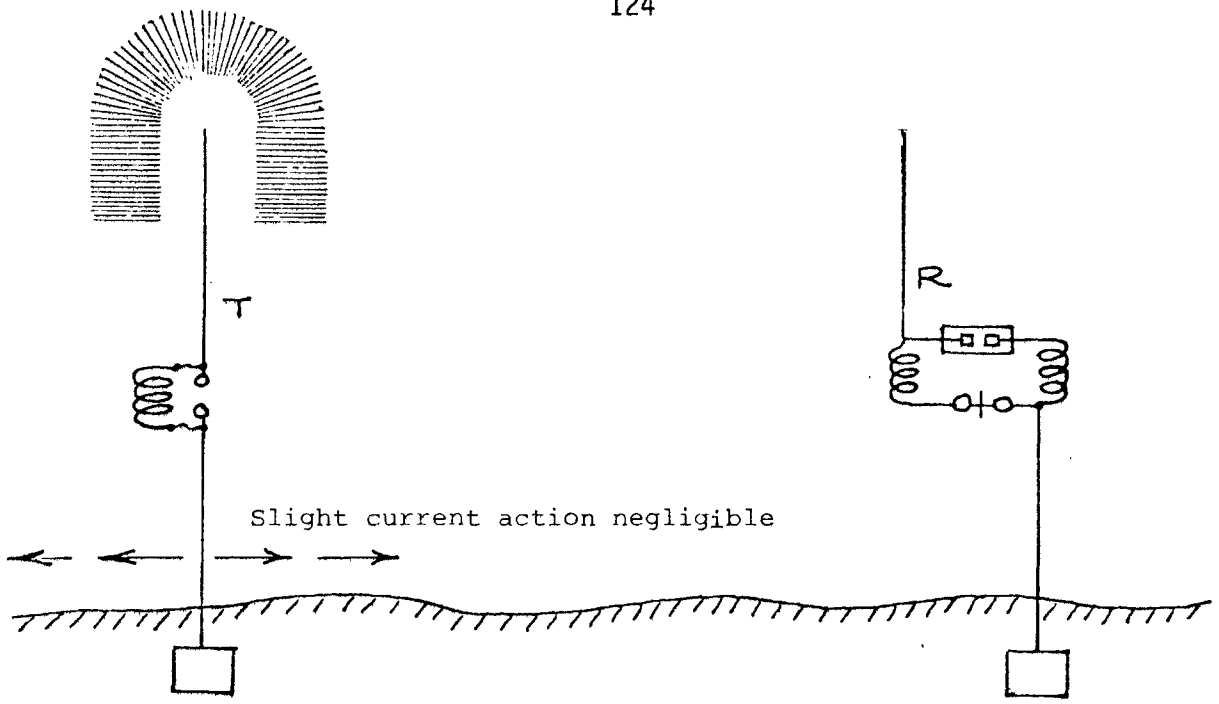

Fig. 1 - Hertz Wave System

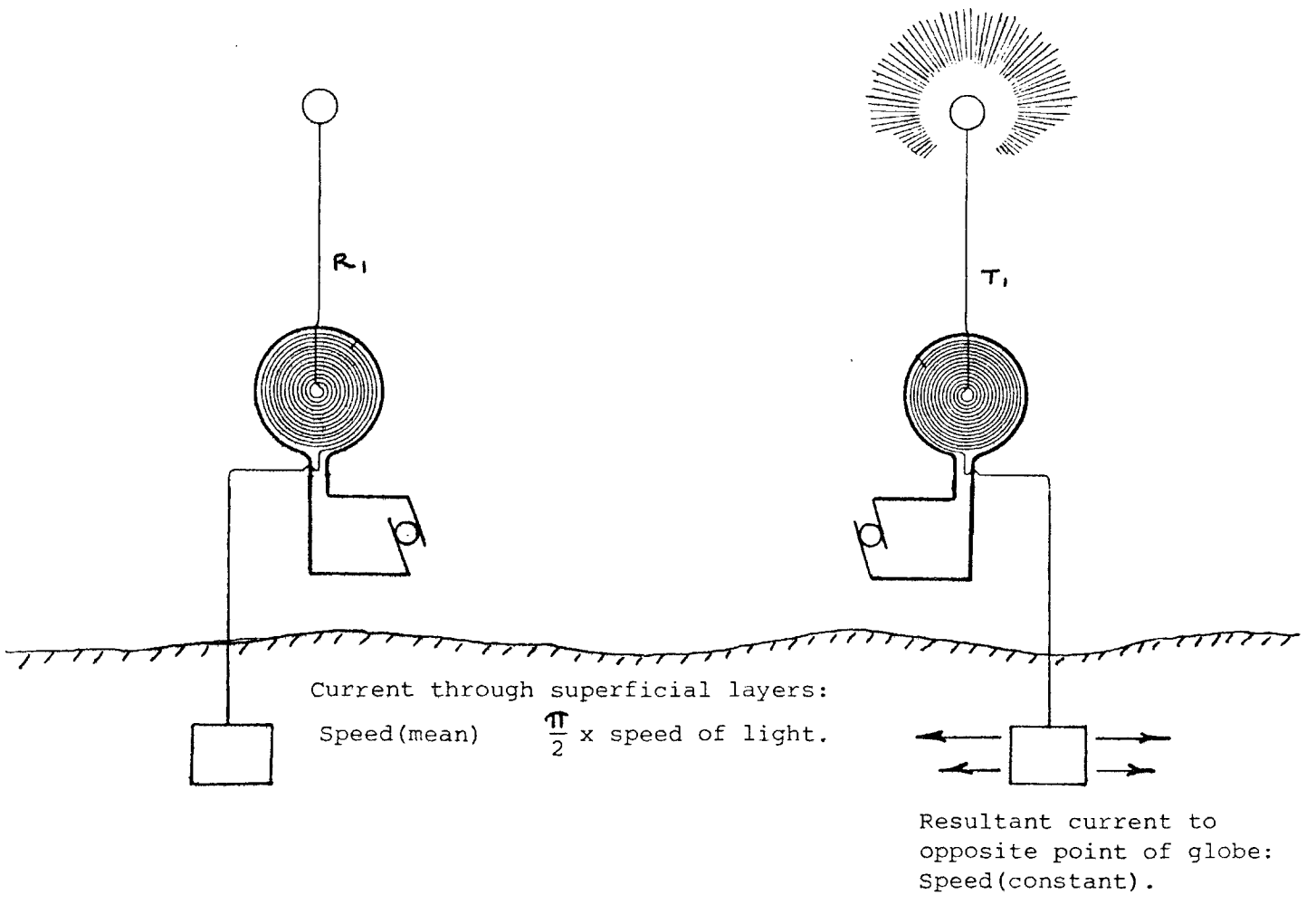

Fig. 2 - System Devised by Tesla

conducted along the earth as through a wire, energy radiated playing no part, it will be at once evident that the weakening of the impulses could not be due to any changes in the air, making it turbid or conductive, but should be traced to an effect interfering with the transmission of the current through the superficial layers of the globe. The solar radiations are the primary cause. that is true, not those of light, but of heat. The loss of energy, I have found, is due to the evaporation of the water on that side of the earth which is turned toward the sun, the conducting particles carrying off more or less of the electrical charges imparted to the ground. This subject has been investigated by me for a number of years and on some future occasion I propose to dwell on it more extensively. At present it may be sufficient, for the guidance of experts, to state that the waste of energy is proportional to the product of the square of the electric density induced by the transmitter at the earth's surface and the frequency of the currents. Expressed in this manner it may not appear of very great practical significance. But remembering that the surface density increases with the frequency it may also be stated that the loss is proportional to the cube of the frequency. With waves 300 meters in length economic transmission of energy is out of the question, the loss being too great. When using wave-lengths of 6,000 meters it is still noticeable though not a serious drawback. With wave-lengths of 12,000 meters it becomes quite insignificant and on this fortunate fact rests the future of wireless transmission of energy.

To assist investigation of this interesting and important subject, Fig. 3 has been added, showing the earth in the position of summer solstice with the transmitter just emerging from the shadow. Observation will bring out the fact that the weakening is not noticeable until the aerials have reached a position, with reference to the sun, in which the evaporation of the water is distinctly more rapid. The maximum will not be exactly when the angle of incidence of the sun's rays is greatest, but some time after. It is noteworthy that the experimenters who watched the effect of the recent eclipse, above referred to, have observed the delay.

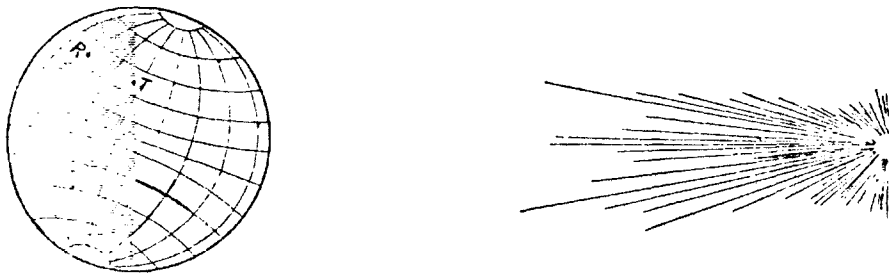

Fig. 3 - Illustrating Disturbing Effect of the Sun on Wireless Transmission.

New York Press
Nov. 9, 1913

NIKOLA TESLA'S PLAN TO KEEP "WIRELESS THUMB" ON SHIPS AT SEA

Suggests Transmitters Powerful Enough to Cause the Earth to Vibrate at the Poles and Equator.

He would Determine Vessel's Latitude and Longitude by Measuring the Length of Electric Waves.

Nikola Tesla has come forward to refute the claims of men who recently excited the scientific world with announcements of discovery and invention calculated to crowd the bugbear of scientific warfare back into the primer class, and to safeguard the lives of seafarers. First he takes up and disposes of the announcement of an invention said to enable a receiving ship equipped with wireless to tell the longitude and latitude of a sending ship without the latter vessel offering its own calculations. "It hasn't been done, and it probably will be years before the means for so doing can be applied successfully," he says. As to the power of ultra-violet rays to explode the powder magazine of a warship from a distance, he insists it can't be done through that medium. If charges of powder have been so exploded, he contends, the detonation was accomplished with the familiar waves now utilized by the wireless. But Mr. Tesla admits that in all probability there will come a time when science has so harnessed and developed the means at hand that such results may be obtained. Mr. Tesla sets forth for readers of *The Press* his views on the two subjects as follows:

By Nikola Tesla

The first and incomplete announcements of technical advances should always be taken with a grain of salt. It is true that the newspapers are getting more and more accurate and reliable in putting forth such information, but, nevertheless, the news frequently is misleading.

For instance, not long ago reports widely circulated that powder had been exploded at distance by infra-red or ultra-violet rays, and that a British battleship had been used in a test of this kind, which proved successful. The dispatches gave great opportunity to sensational speculation, but the truth is that there was no novelty whatever in what was done.

A mine or magazine may have been blown up, but this was accomplished in a well-known manner through the application of a kind of electrical waves which are now generally adopted in the transmission of signals without wires. Similar experiments were performed in this country many years ago by myself and others, and quite recently John Hays Hammond, Jr., has done credible work in this direction through the application of an art which has been named "Telautomatics," or wireless control of moving mechanism at a distance.

By means of such telautomatic vessels, surface, and submarine or aerial, a perfect system of coast defense can be established. Torpedoes on this plan also can be controlled from battleships, and there is no doubt they sooner or later will be adopted and their introduction will have a revolutionary effect on the methods of warfare.

The results described are, however, not impossible. It is quite practicable to explode by rays of light a mine at a distance, as by acting, on a mixture of chlorine and hydrogen. Certain dark rays also can be employed to produce destructive effects. As far back as 1897, I disclosed before the New York Academy of Sciences the discovery that Roentgen, or X-rays, projected from certain bulbs have the property of strongly charging an electrical condenser at a distance. The energy so

accumulated readily can be discharged and cause the ignition of some explosive compound.

Says They Can't Penetrate Steel.

But ultra-violet rays are of very short wave lengths and cannot penetrate steel shells, while the longer and more penetrative waves of the infra-red rays are chemically much less active. There is no doubt in my mind that we soon shall be able to project energy at a distance not only in small, but in large amounts, and what the effect of such an achievement will be on existing conditions, words cannot express.

As regards the determination of latitude and longitude of a vessel at sea by wireless, there is nothing in use as yet which would make such direct observation possible. Some suggestions, however, which I have since many years advocated, have been adopted. They are the flashing of time signals over a wide area and the employment of an instrument known as a wireless compass.

Plan for Finding Locations.

These means enable an expert on a vessel to ascertain the exact hour at any sending station within reach, and also, in an imperfect manner, the direction in which it is situated, and from these data it is possible to get a rough idea of the position of the ship relative to the points of reference.

A perfect means for determining not only such and other data important to the navigator already is available, but it may require years to apply it. I refer to the use of the stationary waves, which were discovered by me fourteen years ago. The subject is too technical to be explained in detail, but the average reader can be made to understand the general principle.

The earth is a conductor of electricity, and as such has its own electrical period of vibration. The time of one complete swing is about one-twelfth of a second. In other words, this is the interval the current requires in passing to, and returning from, the diametrically opposite point of the globe.

Now, the wonderful fact is, that notwithstanding its immense size, the earth responds to a great number of vibrations and can be resonantly excited just like a wire of limited dimensions. When this takes place there are formed on its surface stationary parallel circles of equal electrical activity, which can be revealed by properly attuned instruments.

Transmitter at One of the Poles.

Imagine that a transmitter capable of exciting the earth were placed at one of the Poles. Then the crests and hollows of the stationary waves would be in parallel circles with their planes at right angles to the axis of the earth, and from readings of a properly graduated instrument the distance of a vessel carrying the same from the Pole could be at once read, giving accurately the geographical latitude.

In like manner, if a transmitter were placed at a point on the Equator, the longitude could be precisely determined by the same means. But the best plan would be to place three transmitters at properly chosen points on the globe so as to establish three non-interferable systems of stationary waves at right angles to one another. If this were done, innumerable results of the greatest practical value could be realized.

Electrical World - N. Y.
March 21, 1914, p. 637.

FROM NIKOLA TESLA

The first impressions are those to which we cling most in later life. I like to think of George Westinghouse as he appeared to me in 1888, when I saw him for the first time. The tremendous potential energy of the man had only in part taken kinetic form, but even to a superficial observer the latent force was manifest. A powerful frame, well proportioned, with every joint in working order, an eye as clear as a crystal, a quick and springy step - he presented a rare example of health and strength. Like a lion in a forest, he breathed deep and with delight the smoky air of his factories. Though past forty then, he still had the enthusiasm of youth. Always smiling, affable and polite, he stood in marked contrast to the rough and ready men I met. Not one word which would have been objectionable, not a gesture which might have offended - one could imagine him as moving in the atmosphere of a court, so perfect was his bearing in manner and speech. And yet no fiercer adversary than Westinghouse could have been found when he was aroused. An athlete in ordinary life, he was transformed into a giant when confronted with difficulties which seemed unsurmountable. He enjoyed the struggle and never lost confidence. When others would give up in despair he triumphed. Had he been transferred to another planet with everything against him he would have worked out his salvation. His equipment was such as to make him easily a position of captain among captains, leader among leaders. His was a wonderful career filled with remarkable achievements. He gave to the world a number of valuable inventions and improvements, created new industries, advanced the mechanical and electrical arts and improved in many ways the conditions of modern life. He was a great pioneer and builder whose work was of far-reaching effect on his time and whose name will live long in the memory of men.

Nikola Tesla

Reprinted with permission. Reprinted from March 21, 1914, issue of *Electrical World*.
© Copyright 1914, McGraw-Hill, Inc. All rights reserved.

New York Sun
May 22, 1914

TESLA AND MARCONI.

The Servian Expert's Claim to and Earlier Patent on Sundry Wireless Devices.

To the Editor of The Sun - Sir: The reports contained in The Sun and other journals regarding the issue of a recent wireless patent suit are of a nature to create an erroneous impression. Two of the patents mentioned, namely, Nos. 11,913 and 609,154, granted respectively to William Marconi and Sir Oliver Lodge, are of no importance, but another patent of the former expert, dated June 28, 1904, contains arrangements on which I obtained full protection more than three years before and which are essential to the successful practice of the wireless art at any considerable distance.

My patents bear the numbers 645,576 and 649,621 and were secured through Kerr, Page & Cooper, attorneys for the General Electric and Westinghouse companies. The apparatus described by me comprises four circuits peculiarly arranged and carefully attuned so as to secure the greatest possible flow of electrical energy through them. The generator is a transformer of my invention and the oscillations employed are of

a kind which are now known in technical literature as the Tesla currents. Every one of these elements, even to the last detail, is contained in the Marconi patent which was involved in the suit, and its use constitutes an infringement of all the fundamental features of my wireless system.

Nikola Tesla
New York, March 21, 1914.

New York Times
Sunday, Oct. 3, 1915, p. 14, cols. 1,2,3.

NIKOLA TESLA SEES A WIRELESS VISION

Thinks His "World System" Will Allow Hundreds To Talk At Once Through The Earth.
Ends Static Disturbance.

Inventor Hopes Also To Transmit Pictures By The Same Medium Which Carries The Voice.

Nikola Tesla announced to The Times last night that he had received a patent on an invention which would not only eliminate static interference, the present bug-aboo of wireless telephony, but would enable thousands of persons to talk at once between wireless stations and make it possible for those talking to see one another by wireless, regardless of the distance separating them. He said also that with his wireless station now in the process of construction on Long Island he hoped to make New York one of the central exchanges in a world system of wireless telephony.

Mr. Tesla has been working on wireless problems for many years. Yesterday he exhibited an article published in the Electrical World eleven years ago, in which he predicted not only wireless telephony on a commercial basis but that it would be possible to identify the voice of an acquaintance over any distance. That its operator in Hawaii was able to distinguish the voice of an engineer friend at Arlington, Va., was announced by the American Telephone and Telegraph Company as the most marked triumph of its communication by wireless telephone from the naval radio station at Arlington to Pearl Harbor, Hawaii, a distance of 4,000 miles.

The inventor, who has won fame by his electrical inventions, dictated this statement yesterday.

"The experts carrying out this brilliant experiment are naturally deserving of great credit for the skill they have shown in perfecting the devices. These are of two kinds: First, those serving to control transmission, and, second, those magnifying the received impulse. That the control of transmission is perfect is plain to experts from the fact the Arlington, Mare Island, and Pearl Harbor plants are all inefficient and that the distance of telephonic transmission is equal to that of telegraphic transmission. It is also perfectly apparent that the chief merit of the application lies in the magnification of the microphonic impulse. It must not be imagined that we deal here with new discoveries. The improvement simply concerns the control of the transmitted and the magnification of the received impulse, but the wireless system is the same. This can never be changed.

"That it is practicable to project the human voice not only to a distance of 5,000 miles, but clear across the globe, I demonstrated by experiments in Colorado in 1899. Among my publications I would refer to an article in the Electrical World of March 5, 1904, but describing really tests I made in 1899. The facts which I pointed out in the article were of much greater significance than that of the experiments reported, although this should be taken in a scientific sense, as the experiments were

simply scientific demonstrations. I pointed out then that the modulations of the human voice can be reproduced more clearly through the earth than through wire. It is difficult for the layman to understand, but it is an absolute fact that transmission through the earth with the proper apparatus is not more difficult than the sending of a message on a wire strung across a room. This wonderful property of the planet, that, electrically speaking, is through its very bigness, small, is of incalculable significance for the future of mankind.

"These tests made between Washington and Honolulu will act as an immense stimulus to wireless telephony and would be of much more value to the world if the principles of the transmission were understood. But they are not. Even now, fifteen years after the fundamental principles have been demonstrated and the possibilities shown, there are many experts in the dark.

"For instance, it is claimed that static disturbances will fatally interfere with the transmission, while, as a matter of fact, there is no static disturbance possible in properly designed transmission and receiving circuits. Quite recently I have described in a patent, circuits which are absolutely immune to static and other interferences - so much so that when a telephone is attached, there is absolute silence, even lightning in the immediate vicinity not producing a click of the diaphragm, while in the ordinary telephonic conversation there are all kinds of noises. Transmission without static interference has many wonderful properties, besides, first of which is that unlimited amounts of power can be transmitted with very small loss.

"Another contention is that there can be no secrecy in wireless telephone conversation. I say it is absurd to raise this contention when it is positively demonstrated by experiments that the earth is more suitable for transmission than any wire could ever be. A wireless telephone conversation can be made as secret as thought.

"I have myself erected a plant for the purpose of connecting by wireless telephone the chief centres of the world, and from this plant as many as a hundred will be able to talk absolutely without interference and with absolute secrecy. This plant would simply be connected with the telephone central exchange of New York City, and any subscriber will be able to talk to any other telephone subscriber in the world, and all this without any change in his apparatus. This plan has been called my "world system". By the same means I propose also to transmit pictures and project images, so that the subscriber will not only hear the voice, but see the person to whom he is talking. Pictures transmitted over wires is a perfectly simple art practiced today. Many inventors have labored on it, but the chief credit is due Professor Korn of Munich.

"His apparatus can be attached to a wireless plant and at any other wireless plant can be reproduced. I have undertaken this in the hope of establishing a service which would greatly facilitate the work of the press. A picture could be sent from a battlefield in Europe to New York in five minutes if the proper instruments were available.

"A further advantage would be that transmission is instant and free of the unavoidable delay experienced with the use of wires and cables. As I have already made known, the current passes through the earth, starting from the transmission station with infinite speed, slowing down to the speed of light at a distance of 6,000 miles, then increasing in speed from that region and reaching the receiving station again with infinite velocity.

"It's all a wonderful thing. Wireless is coming to mankind in its full meaning like a hurricane some of these days. Some day there will be, say, six great wireless telephone stations in a world system connecting all the inhabitants on this earth to one another, not only by voice, but by sight. It's surely coming.

New York Times

Oct. 4, 1915 p. 4, col. 3

CORRECTION BY MR. TESLA

Of Wireless Apparatus He meant to Say "Ineffective," not "Inefficient."

The Times received last night from Nikola Tesla a letter saying the inventor wished to correct a statement in his forecast of the possibilities of wireless, published in the Times of yesterday morning, when he was quoted as saying that the apparatus used by the American Telephone and Telegraph Co. to talk from Arlington to Hawaii was "inefficient." The inventor wrote that he wished to say that the apparatus was "ineffective."

"Although I can guess the character of the apparatus which was employed in projecting the human voice through 4,600 miles of space," Mr. Tesla wrote, "I am unable to judge of its efficiency, but from the technical particulars available I know that the plants are ineffective, inasmuch as they would have furnished currents of much greater volume and tension had they been differently designed. Incidentally, they would then have been immune against static disturbances, unfailing in their operation and adapted to secure secrecy of messages.

"In calling attention to this fact I have meant to give testimony to the excellence of the means of control and magnification resorted to by the experimenters. Had the same devices been used in connection with plants designed for maximum effect the results would have been such as to cause a most profound sensation and to stir great commercial interests all the world over, perhaps to the point of powerfully affecting and hastening the finish of the awful struggle in which nations of the earth are now engaged."

NUMBER (Series of 1915)
309182

1916

(EX'R'S BOOK) 766-10/700

1329559

DIV. ~~18~~ 30#

PATENT No.

Name

Nikola Tesla

County of

State of

Invention

191

of New York

New York

Valvular Conduit

filed

PART OF APPLICATION FILED

ORIGINAL

RENEWED

Petition	Feb 21	1916
Affidavit	"	" 1916
Specification	"	" 1916
Drawing (1)	"	" 1916
Photo Copy		1916
First Fee Cash	\$45 Feb 21	1916
" Cert.		1916
Appl. filed complete	Feb 21	1916

	July 8	1916
	July 8	1916
	July 8	1916
	July 15	1916

Examined and Passed for Issue Jan 6, 1919

Arthur W. Cowles Exr. Div. 39

Arthur W. Cowles Exr. Div.

Notice of Allowance Jan 6, 1919
By Commissioner

July 15, 1916

Final Fee Cash 1916

\$20 Jan 5, 1916

" " Cert. 1916

Patented

Attorney Kerr, Page, Cooper & Hayward 55 26
New York, N. Y. etc

Associate Attorney

(No. of Claims Allowed. 7) Title as Allowed Valvular Conduit
(Print claim 1 in O.G.) (cl.)

(For additional patent histories see Dr. Nikola Tesla -
Selected Patent Wrappers From the National Archives -
4 vols., compiled by John T. Ratzlaff, Tesla Book Co.-Ed.)

13A-169
15/12:37-3-1
10591

1916
CONTENTS:

5391
15/12:37-3-1
10591

9K

1. Application ¹ papers:	26.
✓ 2. Reg June 3, 1916	27.
✓ 3. Reg Nov 25, 1916	28.
4. Audit C. Nov 24 1917	29.
✓ 5. Reg Dec 17, 1917	30.
✓ 6. Audit B. Dec 16, 1916	31.
7.	32.
8.	33.
9.	34.
10.	35.
11.	36.
12.	37.
13.	38.
14.	39.
15.	40.
16.	41.
17.	42.
18.	43.
19.	44.
20.	45.
21.	46.
22.	47.
23.	48.
24.	49.
25.	50.

107
107
107

Serial No. 79703 Paper No. 1
Application



Petition.

To the Commissioner of Patents:

Your petitioner Nikola Tesla, a citizen of the United States,

559

residing at New York, in the County and State of New York,

Post Office address 8 West 40th Street, New York, N.Y.,

prays that Letters Patent may be granted to him for the new and useful improvements in

Valvular Conduit,

set forth in the annexed specification;

And he hereby appoints Kerr, Page, Cooper & Hayward (a firm composed of Thomas B. Kerr, Parker W. Page, Drury W. Cooper, John C. Kerr, and Jonathan B. Hayward, Reg. No. 8894), of No. 55 Liberty Street, New York, N. Y., his attorneys, with full power of substitution and revocation, to prosecute this application, to make alterations and amendments therein, to sign the drawings, to receive the patent, and to transact all business in the Patent Office connected therewith.

Inventor's full name here :

Nikola Tesla

Specification.

To all whom it may concern:

Be it known that I, Nikola Tesla, a citizen of the United States,

residing at New York, in the County and

State of New York,

have invented certain new and useful improvements in

Valvular Conduit,

of which the following is a full,

clear, and exact description.

11.
867 /

N. TESLA.
VALVULAR CONDUIT.

APPLICATION FILED FEB. 21, 1916. RENEWED JULY 8, 1919.

1,329,559.

Patented Feb. 3, 1920.

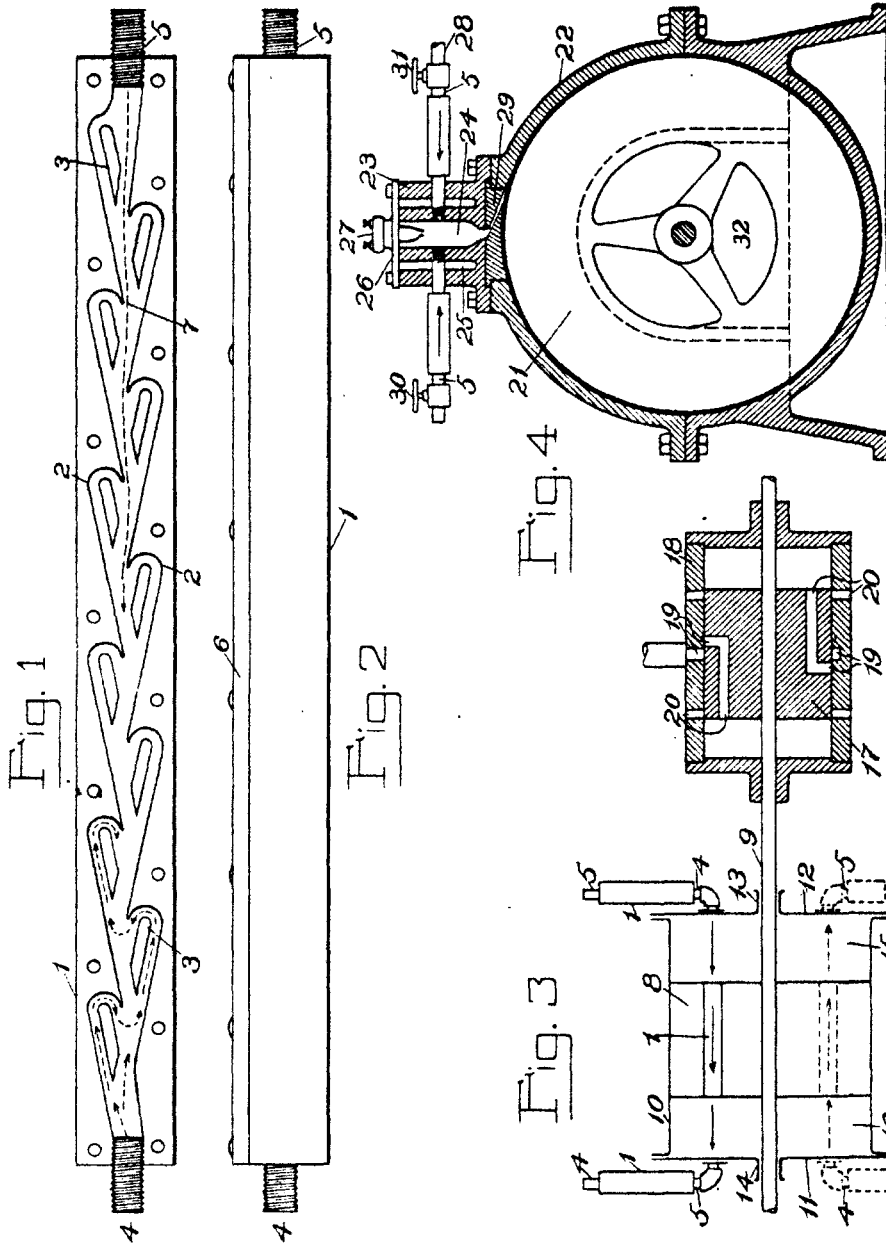

INVENTOR

Nikola Tesla

BY

Spencer, Page, Cooper & Raymond
ATTORNEYS

In most of the machinery universally employed for the development, transmission and transformation of mechanical energy, fluid impulses are made to pass, more or less freely, through suitable channels or conduits in one direction while their return is effectively checked or entirely prevented. This function is generally performed by devices designated as valves, comprising carefully fitted members the precise relative movements of which are essential to the efficient and reliable operation of the apparatus. The necessity of, and absolute dependence on these, limits the machine in many respects, detracting from its practical value and adding greatly to its cost of manufacture and maintenance. As a rule the valve is a delicate contrivance, very liable to wear and get out of order and thereby imperil ponderous, complex and costly mechanism and, moreover, it fails to meet the requirements when the impulses are extremely sudden or rapid in succession and the fluid is highly heated or corrosive.

Though these and other correlated facts were known to the very earliest pioneers in the science and art of mechanics, no remedy has as yet been found or proposed to date so far as I am aware, and I believe that I am the first to discover or invent any means, which permit the performance of the above function without the use of moving parts, and which it is the object

of this application to describe.

Briefly expressed, the advance I have achieved consists in the employment of a peculiar channel or conduit characterized by valvular action.

The invention can be embodied in many constructions greatly varied in detail, but for the explanation of the underlying principle it may be broadly stated that the interior of the conduit is provided with enlargements, recesses, projections, baffles or buckets which, while offering virtually no resistance to the passage of the fluid in one direction, other than surface friction, constitute an almost impassable barrier to its flow in the opposite sense by reason of the more or less sudden expansions, contractions, deflections, reversals of direction, stops and starts and attendant rapidly succeeding transformations of the pressure and velocity energies.

For the full and complete disclosure of the device and of its mode of action reference is made to the accompanying drawings in which

Fig. 1 is a horizontal projection of such a valvular conduit with the top plate removed,

Fig. 2 is side view of the same in elevation;

Fig. 3 is a diagram illustrative of the application of the device to a fluid propelling machine such as, a reciprocating pump or compressor, and

Fig. 4 is a plan showing the manner in which the invention is, or may be used, to operate a fluid propelled rotary engine or turbine.

Referring to Fig. 1, 1 is a casing of metal or other suitable material which may be cast, milled or pressed from sheet in the desired form. From its side-walls extend alternatively projections terminating in buckets 2 which, to facilitate manufacture are congruent and spaced at equal distances, but need not be. In addition to these there are independent partitions 3 which are deemed of advantage and the purpose of which will be made clear. Nipples 4 and 5, one at each end, are provided for pipe connection. The bottom is solid and the upper or open side is closed by a fitting plate 6 as shown in fig. 2. When desired any number of such pieces may be joined in series, thus making up a valvular conduit of such length as the circumstances may require.

In elucidation of the mode of operation let it be assumed that the medium under pressure be admitted at 5. Evidently, its approximate path will be as indicated by the dotted line 7, which is nearly straight, that is to say, if the channel be of adequate cross-section, the fluid will encounter a very small resistance and pass through freely and undisturbed, at least to a degree. Not so if the entrance be at the opposite end 4. In this case the flow will not be smooth and continuous, but intermittent, the fluid being quickly deflected and reversed in direction, set in whirling motion, brought to rest and again accelerated, these processes following one another in rapid succession. The partitions 3 serve to direct the stream upon the buckets and to intensify the actions causing violent surges and eddies which interfere

very materially with the flow through the conduit. It will be readily observed that the resistance offered to the passage of the medium will be considerable even if it be under constant pressure, but the impediments will be of full effect only when it is supplied in pulses and, more especially, when the same are extremely sudden and of high frequency. In order to bring the fluid masses to rest and to high velocity in short intervals of time energy must be furnished at a rate which is unattainable, the result being that the impulse cannot penetrate very far before it subsides and gives rise to movement in the opposite direction. The device not only acts as a hinderment to the bodily return of particles but also, in a measure, as a check to the propagation of a disturbance through the medium. Its efficacy is chiefly determined; first, by the magnitude of the ratio of the two resistances offered to disturbed and to undisturbed flow, respectively, in the directions from 4 to 5 and from 5 to 4, in each individual element of the conduit; second, by the number of complete cycles of action taking place in a given length of the valvular channel and, third, by the character of the impulses themselves. A fair idea may be gained from simple theoretical considerations.

Examining more closely the mode of operation it will be seen that, in passing from one to the next bucket in the direction of disturbed flow, the fluid undergoes two complete reversals or deflections through 180 degrees while it suffers only two small deviations from about 10 to 20 degrees when moving in the opposite sense. In each

case the loss of head will be proportionate to a hydraulic coefficient dependent on the angle of deflection from which it follows that, for the same velocity, the ratio of the two resistances will be as that of the two coefficients. The theoretical value of this ratio may be 200 or more, but must be taken as appreciably less although the surface friction too is greater in the direction of disturbed flow. In order to keep it as large as possible, sharp bends should be avoided, for these will add to both resistances and reduce the efficiency. Whenever practicable, the piece should be straight; the next best is the circular form.

That the peculiar function of such a conduit is enhanced by increasing the number of buckets or elements and, consequently, cyclic processes in a given length is an obvious conclusion, but there is no direct proportionality because the successive actions diminish in intensity. Definite limits, however, are set constructively and otherwise to the number of elements per unit length of the channel, and the most economical design can only be evolved through long experience.

Quite apart from any mechanical features of the device the character of the impulses has a decided influence on its performance and the best results will be secured, when there are produced at 4, sudden variations of pressure in relatively long intervals, while a constant pressure is maintained at 5. Such is the case in one of its most valuable industrial applications which will be specifically described.

In order to conduce to a better understanding, reference may first be made to Fig. 3 which illustrates another special use and in which B is a piston fixed to

a shaft 9 and fitting freely in a cylinder 10. The latter is closed at both ends by flanged heads 11 and 12 having sleeves or stuffing boxes 13 and 14 for the shaft. Connection between the two compartments, 15 and 16, of the cylinder is established through a valvular conduit and each of the heads is similarly equipped. For the sake of simplicity these devices are diagrammatically shown, the solid arrows indicating the direction of undisturbed flow. An extension of the shaft 9 carries a second piston 17 accurately ground to and sliding easily in a cylinder 18 closed at the ends by plates and sleeves as usual. Both piston and cylinder are provided with inlet and outlet ports marked, respectively, 19 and 20. This arrangement is familiar, being representative of a prime mover of my invention, termed "mechanical oscillator", with which it is practicable to vibrate a system of considerable weight many thousand times per/minute.

Suppose now that such rapid oscillations are imparted by this or other means to the piston 8. Bearing in mind the proceeding, the operation of the apparatus will be understood at a glance. While moving in the direction of the solid arrow, from 12 to 11, the piston 8 will compress the air or other medium in the compartment 16 and expel it from the same, the devices in the piston and head 11 acting, respectively, as closed and open valves. During the movement of the piston in the opposite direction, from 11 to 12, the medium which has meanwhile filled the chamber 15 will be transferred to compartment 16, egress being prevented by the device in head 12 and that in the piston allowing free passage. These processes will be repeated in very quick succession. If the nipples 4

and 5 are put in communication with independent reservoirs, the oscillations of the piston 8 will result in a compression of the air at 4 and rarefaction of the same at 5. Obviously, the valvular channels being turned the other way, as indicated by dotted lines in the lower part of the figure, the opposite will take place. The devices in the piston have been shown merely by way of suggestion and can be dispensed with. Each of the chambers 15 and 16 being connected to two conduits as illustrated, the vibrations of a solid piston as 8 will have the same effect and the machine will then be a double acting pump or compressor. It is likewise unessential that the medium should be admitted to the cylinder through such devices for in certain instances ports, alternately closed and opened by the piston, may serve the purpose. As a matter of course, this novel method of propelling fluids can be extended to multistage working in which case a number of pistons will be employed, preferably on the same shaft and of different diameters in conformity with well established principles of mechanical design. In this way any desired ratio of compression or degree of rarefaction may be attained.

Fig.4 exemplifies a particularly valuable application of the invention to which reference has been made above. The drawing shows in vertical cross section a turbine which may be of any type but is in this instance one invented and described by me and supposed to be familiar to engineers. Suffice it to state that the rotor 21 of the same is composed of flat plates which are set in motion through the adhesive and viscous action of the working fluid, entering the system tangentially at the periphery and leaving it at the center. Such a machine is a thermo-

dynamic transformer of an activity surpassing by far that of any other prime mover, it being demonstrated in practice that each single disk of the rotor is capable of performing as much work as a whole bucketwheel. Besides, a number of other advantages, equally important, make it especially adapted for operation as an internal combustion motor. This may be done in many ways, but the simplest and most direct plan of which I am aware is the one illustrated here. Referring again to the drawing, the upper part of the turbine casing 22 has bolted to it a separate casting 23, the central cavity 24 of which forms the combustion chamber. To prevent injury through excessive heating a jacket 25 may be used, or else water injected, and when these means are objectionable recourse may be had to air cooling, this all the more readily as very high temperatures are practicable. The top of casting 23 is closed by a plate 26 with a sparking or hot wire plug 27 and in its sides are screwed two valvular conduits communicating with the central chamber 24. One of these is, normally, open to the atmosphere while the other connects to a source of fuel supply as a gas main 28. The bottom of the combustion chamber terminates in a suitable nozzle 29 which consists of separate piece of heat resisting material. To regulate the influx of the explosion constituents and secure the proper mixture the air and gas conduits are equipped, respectively, with valves 30 and 31. The exhaust openings 32 of the rotor should be in communication with a ventilator, preferably carried on the same shaft and of any suitable construction. Its use, however, while advantageous, is not indispensable the suction produced by the turbine rotor itself being, in some cases at least, suffi-

cient to insure proper working. This detail is omitted from the drawing as unessential to the understanding.

But a few words will be needed to make clear the mode of operation. The air valve 30 being open and sparking established across terminals 27, the gas is turned on slowly until the mixture in the chamber 24 reaches the critical state and is ignited. Both the conduits behaving, with respect to efflux, as closed valves, the products of combustion rush out through the nozzle 29 acquiring still greater velocity by expansion and, imparting their momentum to the rotor 21, start it from rest. Upon the subsidence of the explosion the pressure in the chamber sinks below the atmospheric owing to the pumping action of the rotor or ventilator and new air and gas is permitted to enter, cleaning the cavity and channels and making up a fresh mixture which is detonated as before, and so on, the successive impulses of the working fluid producing an almost continuous rotary effort. After a short lapse of time the chamber becomes heated to such a degree that the ignition device may be shut off without disturbing the established regime. This manner of starting the turbine involves the employment of an unduly large combustion chamber which is not commendable from the economic point of view, for not only does it entail increased heat losses but the explosions cannot be made to follow one another with such rapidity as would be desirable to insure the best valvular action. When the chamber is small an auxiliary means for starting, as compressed air, may be resorted to and a very quick succession of explosions can then be obtained. The frequency will be the greater the stronger the suction, and may, under

certain conditions, reach hundred and even thousands per second. It scarcely need be stated that instead of one several explosion chambers may be used for cooling purposes and also to increase the number of active pulses and the output of the machine.

Apparatus as illustrated in Fig.4 presents the advantages of extreme simplicity, cheapness and reliability, there being no compressor, buckets or troublesome valve mechanism. It also permits, with the addition of certain well-known accessories, the use of any kind of fuel and thus meets the pressing necessity of a self-contained, powerful, light and compact internal combustion motor for general work. When the attainment of the highest efficiency is the chief object, as in machines of large size, the explosive constituents will be supplied under high pressure and provision made for maintaining a vacuum at the exhaust. Such arrangements are quite familiar and lend themselves so easily to this improvement that an enlargement on this subject is deemed unnecessary.

The foregoing description will readily suggest to experts modifications both as regards construction and application of the device and I do not wish to limit myself in these respects. The broad underlying idea of the invention is to permit the free passage of a fluid through a channel in the direction of the flow and to prevent its return through friction and mass resistance, thus enabling the performance of valve functions without any moving parts and thereby extending the scope and usefulness of an immense variety of mechanical appliances.

I do not claim the methods of and apparatus for the propulsion of fluids and thermo-dynamic transforma-

tion of energy herein disclosed, as these will be made subjects of separate applications.

What I claim is:

1: A valvular conduit having interior walls of such conformation as to permit the free passage of fluid through it in the direction of flow, but to prevent its return by friction and mass resistance.

2: A valvular conduit composed of a closed passageway having recesses in its walls so formed as to permit a fluid to pass freely through it in the direction of flow, but to deflect said fluid and thereby interpose friction and mass resistance to the return passage of the same.

3: A valvular conduit composed of a tube or passage way with rigid interior walls formed with a series of recesses or pockets with surfaces that deflect a fluid tending to flow in one direction therein, and to check or prevent the flow of the fluid in that direction.

4: A valvular conduit with rigid interior walls of such character as to offer substantially no obstacle to the passage through it of fluid impulses in one direction, but to oppose and check those in the opposite direction.

5: A valvular conduit with rigid interior walls formed to permit fluid impulses under pressure to pass freely through it in one direction, but to deflect them and check their progress when impelled in the opposite direction.

6: A valvular conduit with rigid interior walls which permit fluid impulses to flow through it freely in one direction, formed at a plurality of points to deflect

such fluid impulses when impelled in the opposite direction and check their flow.

70 A valvular conduit with rigid interior walls having pockets or recesses, and transversely inclined intermediate baffles to permit the free passage of fluid impulses in one direction but to deflect and check them when impelled in the opposite direction.

In testimony whereof I affix my signature, in the presence of two subscribing witnesses.

Witnesses: _____ } Nikola Tesla

Oath.

State of New York, } ss.
County of New York.

Nikola Tesla,

the above-named petitioner being duly sworn, deposes and says that he is a citizen of the United States, and resident of New York, in the County and State of New York,

that he verily believes himself to be the original, first, and sole inventor of the improvements in Valvular Conduit,

described and claimed in the annexed specification; that he does not know and does not believe the same were ever known or used before his invention or discovery thereof, or patented or described in any printed publication in the United States of America or in any foreign country before his invention or discovery thereof, or more than two years prior to this application; or in public use or on sale in the United States for more than two years prior to this application; that said invention has not been patented in any country foreign to the United States, on an application filed by him or his legal representatives or assigns more than twelve months prior to this application, and that no application for patent on said improvements has been filed by him or his legal representatives or assigns in any country foreign to the United States.

Inventor's full name here: } Nikola Tesla

Sworn to and subscribed before me this 18th day of February, 1916.

(A's Seal here.)

M. Lawson Dyar
Notary Public 119 W. Co. 1

Div. 39 Room 321

2-260

AWC/D

The Commissioner of Patents,
Washington, D. C.,
and not any official by name.

Paper No. 2-11
All communications respecting this
application should give the serial number,
date of filing, title of invention, and
name of the applicant.

DEPARTMENT OF THE INTERIOR
UNITED STATES PATENT OFFICE

WASHINGTON

June 3, 1916.

Kerr, Page, Cooper & Haywood,
55 Liberty St.,
New York, N. Y.

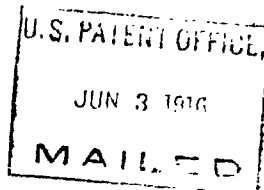

Please find below a communication from the EXAMINER in charge of the application of

Nikola Tesla, filed Feb. 21, 1916, #79,703. VALVULAR CONDUIT.

6-2531

Thomas Ewing
Commissioner of Patents

This case has been examined.

The claims are all rejected on either patent:

German to Lobe, 501 of 1877, Class 137.75

" " Lappa, 199,580 of 1908, Class 137.75 (x)

" " Overhoff, 224,759, of 1910, " "

Arthur W. G. ...

Examiner.

Div. 39 Room 321
Adm. Only
 "The Commissioner of Patents,
 Washington, D. C.,"
 and not any official by name.

2-260

LM/ATH

Paper No. 5
 All communications respecting this
 application should give the serial number,
 date of filing, title of invention, and
 name of the applicant.

DEPARTMENT OF THE INTERIOR
 UNITED STATES PATENT OFFICE

WASHINGTON

Nov. 25, 1916.

Kerr, Page, Cooper and Hayward,

55 Liberty St.,

New York City.

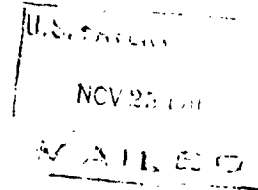

Please find below a communication from the EXAMINER in charge of the application of

Nikola Tesla, Ser. No. 79,703, filed Feb. 21, 1916 for

Valvular Conduit.

c. 6-2831

Thomas Ewing
 Commissioner of Patents.

This is supplementary to the Office action of June 3, 1916.

The claims are all rejected upon the Swiss patent to
 Edwards, 18,298 of 1896, (Klasse 95), 137-112.

See especially Fig. 1^a, Fig. 3 and Fig. 4 in this patent.

The Examiner regrets that the Swiss patent was not discovered
 in the first search, it having been found now in another class of
 art in the Office.

Applicant has one year from this date in which to amend
 his case.

L. M.

Arthur E. Cowley

Examiner, Div. 39.

Serial No. 7970 Paper No. 4
Amendment a

Nikola Tesla
Valvular Conduit
Filed February 12, 1916
Serial No. 79,703

Chicago, Ill., November 23, 1917.

Hon. Commissioner of Patents,
Washington, D. C.

Sir:

In response to Patent Office action dated November 25, 1916, I amend as follows:

Add to the specification the following, after line 2 of page 11;

a' - - - I am aware that asymmetrical conduits have been constructed and their use proposed in connection with engines, but these have no similiarity either in their construction or manner of employment with my valvular conduit. They were incapable of acting as valves proper, for the fluid was merely arrested in pockets and deflected through 90°, this result having at best only 25% of the efficiency attained in the construction herein described. In the conduit I have designed the fluid, as stated above, is deflected in each cycle through 360°, and a co-efficient approximating 200 can be obtained so that the device acts as a slightly leaking valve, and for that reason the term "valvular" has been given to it in contrast to asymmetrical conduits, as heretofore proposed, which were not valvular in action, but merely asymmetrical as to resistance.

Furthermore, the conduits heretofore constructed were intended to be used in connection with slowly reciprocating machines, in which case enormous conduit-length would be necessary, all this rendering them devoid of practical value. By the use of an effective valvular conduit, as herein described, and the

1.

[This page retyped from original for better readability - Ed.]

employment of pulses of very high frequency. I am able to condense my apparatus and secure such perfect action as to dispense successfully with valves in numerous forms of reciprocating and rotary engines.

Insert B

Cancel claims 1 to 6 inclusive, and substitute --

a²

1. A valvular conduit having interior walls of such conformation as to permit the free passage of fluid through it in the direction of flow but ^{to} subject it to rapid reversals of direction when impelled in the opposite sense and thereby to prevent its return by friction and mass resistance.
2. A valvular conduit composed of a closed passageway having recesses in its walls so formed as to permit a fluid to pass freely through it in the direction of flow, but to subject it to rapid reversals of direction when impelled in an opposite sense and thereby interpose friction and mass resistance to the return passage of the same.
3. A valvular conduit composed of a tube or passageway with rigid interior walls formed with a series of recesses or pockets with surfaces that reverse a fluid tending to flow in one direction therein and thereby check or prevent flow of the fluid in that direction.
4. A valvular conduit with rigid interior walls of such character as to offer substantially no obstacle to the passage through it of fluid impulses in one direction, but to subject the fluid to rapid reversals of direction and thereby oppose and check impulses in the opposite sense.
5. A valvular conduit with rigid interior walls formed to permit fluid impulses under pressure to pass freely through it in one direction, but to subject them to rapid reversals of direction through 360° and thereby check their progress

2.

[This page retyped from original for better readability. - Ed.]

when impelled in the opposite sense.

6. A valvular conduit with rigid interior walls which permit fluid impulses to flow through it freely in one direction, formed at a plurality of points to reverse such fluid impulses when impelled in the opposite direction and check their flow.

Reconsideration of claim 7 is requested.

It is thought that the foregoing matter added to the specification makes clear the broader differentiations of the invention set forth in this application from the Swiss patent of reference, and that the claims as amended define applicant's invention in important matters of novelty. Since the Examiner will readily grasp the distinctions thus made, upon his comparative consideration of the specification and claims of this case and the disclosure of the reference, it is believed to be needless to burden the record with more detailed statements of the inadequacy of the reference to meet this case as above presented.

As to claim 7, the intermediate baffles are distinctive.

Chicago, Illinois, this 23rd day
of November, 1917.

Nikola Tesla

Div. 391 Room 220
 Address only
 "The Commissioner of Patents,
 Washington, D. C.,"
 and not any official by name.

2-260

JWM/D

Paper No. 5-E
 All communications respecting this
 application should give the serial number,
 date of filing, title of invention, and
 name of the applicant.

DEPARTMENT OF THE INTERIOR
 UNITED STATES PATENT OFFICE

WASHINGTON

Dec. 17, 1917

Kerr, Page, Cooper & Hayward,
 55 Liberty St.,
 New York, N. Y.

Please find below a communication from the EXAMINER in charge of the application of
 Nikola Tesla, filed Feb. 21, 1916, #79,703.

VALVULAR CONDUIT

James G. Newton
 Commissioner of Patents.

This is in reply to the amendment filed Nov. 24, 1917.

Applicant's new claim and his argument have been care-
 fully considered.

The advantages of applicant's device over any that appears
 in the record are recognized but the broadest reasonable interpreta-
 tion must be given to the language of claims. Inasmuch as neither
 in applicant's device nor in the reference of record is there a com-
 plete prevention of the reversal of flow, apparently the term
 "valvular" may be correctly applied to the devices patented and
 especially in those shown in the Swiss patent and cited in the
 last Office letter. If this position is correct apparently present
 claims 1, 4, and 6 are clearly anticipated by the Swiss patent.

Claims 2 and 3 which recite a construction in which the pock-
^{are}ets/formed not by thickening the wall by means of projections but
 by removing portions of the wall appear to be allowable as advised.

Claim 5 recites a capacity in the device of producing re-
 versals of direction through 360°. Even in connection with appli-
 cant's addition to the specification this feature is not quite clear,
 inasmuch as the "cycle" referred to in the added text is not certain-
 ly defined. Action on the merits of claim 5 is therefore deferred.

Claim 7 retained is now thought to be allowable as advised.

Claims 1, 4, and 6 must be rejected.

JWM

Arthur W. Rowles
 Examiner.

TESLA COMPANY, INC.



STEAM AND GAS TURBINES
BLOWERS COMPRESSORS
VACUUM PUMPS FOUNTAINS
MECHANICAL OSCILLATORS
PRECISION INSTRUMENTS

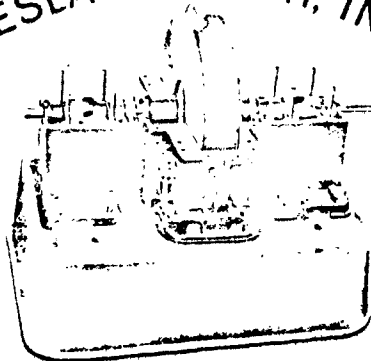

OFFICIAL PAPER NO. 6
DEC 16 1918
U.S. PATENT OFFICE

HIGHFREQUENCY DYNAMOS
LIGHTNING PROTECTORS
INTERFERENCE PREVENTERS
OSCILLATION TRANSFORMERS
SCIENTIFIC NOVELTIES

B.

2722

Nikola Tesla

NEW YORK, 8 WEST 40TH ST.
TEL. 23 VANDERBILT.

Valvular Conduit

December 14, 1918

Filed February 12, 1916

Serial No. 79,703

Hon. Commissioner of Patents,
Washington, D. C.

Sir:

Referring to Official Letter of December 17, 1917 in regard to the above application and argument submitted November 24, 1917, I beg to amend as follows:

Add to last named argument on line 4, page 2, following statement:

The high efficiency of the device, irrespective of the character of the pulses, is due to two causes: first, rapid reversal of direction of flow and, second, great relative velocity of the colliding fluid columns. As will be readily seen each bucket causes a

20

Hon. Commissioner of Patents

-2-

1778

deviation through an angle of 180° , and another change of 180° occurs in each of the spaces between two adjacent buckets. That is to say, from the time the fluid enters or leaves one of the recesses to its passage into, or exit from, the one following a complete cycle, or deflection through 360° , is effected. Observe now that the velocity is but slightly reduced in the reversal so that the incoming and deflected fluid columns meet with a relative speed, twice that of the flow, and the energy of their impact is four times greater than with a deflection of only 90° , as might be obtained with pockets such as have been employed in asymmetrical conduits for various purposes. The fact is, however, that in these such deflection is not secured, the pockets remaining filled with comparatively quiescent fluid and the latter following a winding path of least resistance between the obstacles interposed. In such conduits the action cannot be characterized as "valvular" because some of the fluid can pass almost unimpeded in a direction opposite to the normal flow. In my construction, as above indicated, the resistance in the reverse may be 200 times that in the normal direction. Owing to this a comparatively very small number of buckets or elements is required for checking the fluid. To give a concrete idea, suppose that the leak from the first element is represented by the fraction $\frac{1}{X}$, then after the nth bucket is traversed, only a quantity $\left(\frac{1}{X}\right)^n$ will escape and it is evident that X need not be a

operator have
 # meant by
 hand

Hon. Commissioner of Patents

-3-

2721

large number to secure a nearly perfect valvular action.

I believe that the preceding will meet the Examiner's wish for explicitness in regard to claim 5 and also satisfy him that the characterisation of the action of my device is entirely justified in fact and also as distinctive from the prior art. I trust, therefore, that in view of the importance of the invention and the desirability of using a fitting term, claims 1, 4 and 6 may be allowed in their present form.

Reconsideration is respectfully requested.

Atikole Tesla

22-

ADDRESS ONLY
THE COMMISSIONER OF PATENTS,
WASHINGTON, D. C.

2-181

Serial No.

DEPARTMENT OF THE INTERIOR
UNITED STATES PATENT OFFICE

WASHINGTON Jan. 6, 1919.

Nikalo Tesla,

Sir: Your APPLICATION for a patent for an IMPROVEMENT in
Valvular Conduit.

filed Feb. 21, 1916. , has been examined and ALLOWED.

The final fee, TWENTY DOLLARS, must be paid not later than SIX MONTHS from the date of this present notice of allowance. If the final fee be not paid within that period, the patent on this application will be withheld, unless renewed with an additional fee of \$15, under the provisions of Section 4897, Revised Statutes.

The office delivers patents upon the day of their date, and on which their term begins to run. The printing, photolithographing, and engrossing of the several patent parts, preparatory to final signing and sealing, will require about four weeks, and such work will not be undertaken until after payment of the necessary fee.

When you send the final fee you will also send, DISTINCTLY AND PLAINLY WRITTEN, the name of the INVENTOR, TITLE OF INVENTION, AND SERIAL NUMBER AS ABOVE GIVEN, DATE OF ALLOWANCE (which is the date of this circular), DATE OF FILING, and, if assigned, the NAMES OF THE ASSIGNEES.

If you desire to have the patent issue to ASSIGNEES, an assignment containing a REQUEST to that effect, together with the FEE for recording the same, must be filed in this office on or before the date of payment of final fee.

After issue of the patent uncertified copies of the drawings and specifications may be purchased at the price of FIVE CENTS EACH. The money should accompany the order. Postage stamps will not be received.

Final fees will NOT be received from other than the applicant, his assignee or attorney, or a party in interest as shown by the records of the Patent Office.

Respectfully,

James G. Newton
Commissioner of Patents.

Kerr, Page, Cooper and Hayward,

55 Liberty St.,

New York, N. Y.

IN REMITTING THE FINAL FEE GIVE THE SERIAL NUMBER AT THE HEAD OF THIS NOTICE.

UNCERTIFIED CHECKS WILL NOT BE ACCEPTED

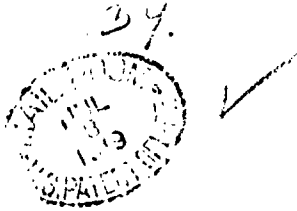

P E T I T I O N .

Your petitioner, NIKOLA TESLA, a citizen of the United States and a resident of New York, in the County and State of New York, whose postoffice address is 8 West 40th Street, New York, N.Y., represents that on February 21, 1916, he filed an application for letters patent for an improvement in Valvular Conduits, Serial No. 79,703, which application was allowed on January 6, 1919, but that he failed to make payment of the final fee within the time allowed by law. He now makes renewed application for letters patent for said invention, and prays that the original specification, oath and drawings may be used as a part of this application

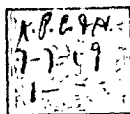

Nikola Tesla

Signed at New York, N.Y.,

this 2nd day of July, 1919.

ADDRESS ONLY
THE COMMISSIONER OF PATENTS,
WASHINGTON, D. C.

2-181

Serial No. 309,482

DEPARTMENT OF THE INTERIOR
UNITED STATES PATENT OFFICE

WASHINGTON July 15, 1919.

IN REMITTING THE FINAL FEE GIVE THE SERIAL NUMBER AT THE HEAD OF THIS NOTICE.

Nikola Tesla,
Sir: Your APPLICATION for a patent for an IMPROVEMENT in
VALVULAR CONDUIT.

filed Feb. 21, 1916. , has been examined and ALLOWED.
The final fee, TWENTY DOLLARS, must be paid not later than
SIX MONTHS from the date of this present notice of allowance.
If the final fee be not paid within that period, the patent on
this application will be withheld, unless renewed with an
additional fee of \$15, under the provisions of Section 4897,
Revised Statutes.

The office delivers patents upon the day of their date, and
on which their term begins to run. The printing, photolitho-
graphing, and engrossing of the several patent parts, prepara-
tory to final signing and sealing, will require about four
weeks, and such work will not be undertaken until after payment
of the necessary fee.

When you send the final fee you will also send, DISTINCTLY
AND PLAINLY WRITTEN, the name of the INVENTOR, TITLE OF INVEN-
TION, AND SERIAL NUMBER AS ABOVE GIVEN, DATE OF ALLOWANCE
(which is the date of this circular), DATE OF FILING, and, if
assigned, the NAMES OF THE ASSIGNEES.

If you desire to have the patent issue to ASSIGNEES, an
assignment containing a REQUEST to that effect, together with
the FEE for recording the same, must be filed in this office on
or before the date of payment of final fee.

After issue of the patent uncertified copies of the draw-
ings and specifications may be purchased at the price of FIVE
CENTS EACH. The money should accompany the order. Postage
stamps will not be received.

Final fees will NOT be received from other than the appli-
cant, his assignee or attorney, or a party in interest as shown
by the records of the Patent Office.

Respectfully,

James S. Newton
Commissioner of Patents.

Kerr, Page, Cooper & Hayward,

55 Liberty St.,

New York, N. Y.

24

UNCERTIFIED CHECKS WILL NOT BE ACCEPTED.

Collier's Weekly
Dec. 2, 1916

WONDERS OF THE FUTURE

By Nikola Tesla

Nikola Tesla is an inventor, electrical wizard, and seer. He is the discoverer of alternating-current power transmission, the system of electrical conversion and distribution by oscillatory discharges, transmission of energy through a single wire without return, a system of wireless transmission of intelligence, transformer, etc. His laboratory is at Shoreham, L. I.

Many a would-be discoverer, failing in his efforts, has felt regret at having been born at a time when, as he thinks, everything has been already accomplished and nothing is left to be done. This erroneous impression that, as we are advancing, the possibilities of invention are being exhausted is not uncommon. In reality it is just the opposite. What has been so far done by electricity is nothing as compared with what the future has in store. Not only this, but there are now innumerable things done in old-fashioned ways which are much inferior in economy, convenience, and many other respects to the new method. So great are the advantages of the latter that whenever an opportunity presents itself the engineer advises his client to "do it electrically."

Water power offers great opportunities for novel electrical applications, particularly in the department of electrochemistry. The harnessing of waterfalls is the most economical method known for drawing energy from the sun. This is due to the fact that both water and electricity are incompressible. The net efficiency of the hydroelectric process can be as high as 85 per cent. The initial outlay is generally great, but the cost of maintenance is small and the convenience offered ideal. My alternating system is invariably employed, and so far about 7,000,000 horsepower as been developed. As generally used, we do not get more than six-hundredths of a horsepower per ton of coal per year. This water energy is therefore equivalent to that obtainable from an annual supply of 120,000,000 tons of coal, which is from 25 to 50 per cent of the total output of the United States.

Great possibilities also lie in the use of coal. From this valuable mineral we chiefly draw the sun's stored energy, which is required to meet our industrial and commercial needs. According to statistical records the output in the United States during an average year is 480,000,000 tons. In perfect engines this fuel would be sufficient to develop 500,000,000 horsepower steadily for one year, but the squandering is so reckless that we do not get more than 5 per cent of its heating value on the average. A comprehensive electrical plan for mining, transporting, and using coal could much reduce this appalling waste. What is more, inferior grades, billions of tons of which are being thrown away, might be turned to profitable use.

Similar considerations apply to natural gas and mineral oil, the annual loss of which amounts to hundreds of millions of dollars. In the very near future such waste will be looked upon as criminal and the introduction of the new methods will be forced upon the owners of such properties. Here, then, is an immense field for the use of electricity in many ways. The manufacture of iron and steel offers another large opportunity for the effective application of electricity.

In the production of pig iron about one ton of coke is employed for every ton. Thus 31,000,000 tons of coke are used a year. There are 4,000,000 cubic feet of gases from the blast furnaces which may be used for power purposes. It is practicable to obtain 2,500,000 horsepower electrical energy in this way.

In the manufacture of coke some 41,000,000 tons of coal are employed in this country. From the gases produced in this process some 1,500,000 horsepower could

be produced in the form of electrical energy.

I have devoted much thought to this industrial proposition, and find that with new, efficient, extremely cheap, and simple thermodynamic transformers not less than 4,000,000 horsepower could be developed in electric generators by utilizing the heat of these gases, which, if not entirely wasted, are only in part and inefficiently employed.

With systematic improvements and refinements much better results could be secured and an annual revenue of \$50,000,000 or more derived. The electrical energy could be advantageously used in the fixation of atmospheric nitrogen and production of fertilizers, for which there is an unlimited demand and the manufacture of which is restricted here on account of the high cost of power. I expect confidently the practical realization of this project in the very near future, and look to exceptionally rapid electrical development in this direction.

But the time is very near when we shall have the precipitation of the moisture of the atmosphere under complete control, and then it will be possible to draw unlimited quantities of water from the oceans, develop any desired amount of energy, and completely transform the globe by irrigation and intensive farming. A greater achievement of man through the medium of electricity can hardly be imagined.

The present limitations in the transmission of power to distance will be overcome in two ways: through the adoption of underground conductors insulated by power, and through the introduction of the wireless art.

When these advanced ideas are practically realized we shall get the full benefit of water power, and it will become our chief dependence in the supply of electricity for domestic, public, and other uses in the arts of peace and war.

A vast and absolutely untouched field is the use of electricity for the propulsion of ships. The leading electrical company in this country equipped a large vessel with high-speed turbines and electric motors. The new equipment was a signal success. Applications of this kind will multiply at a rapid rate, for the advantages of the electrical drive are not patent to everybody. Gyroscopic apparatus will probably play an important part, as its general adoption on vessels is sure to come. Very little has yet been done in the introduction of electrical drive in the various branches of industry and manufacture, but the prospects here are unlimited.

Books have already been written on the uses of electricity in agriculture, but the fact is that very little has been practically done. The beneficial effects of electricity of high tension have been unmistakably established, so that we are warranted in believing that a revolution will be brought about through the extensive adoption of agricultural electrical apparatus. The safeguarding of forests against fires, the destruction of microbes, insects, and rodents will, in due course, be accomplished by electricity.

In the not far distant future we shall see a great many new uses of electricity that will aim at safety. The safety of vessels at sea will be particularly affected. We shall have electrical instruments which will prevent collisions, and we shall even be able to disperse fogs by electric force and powerful and penetrative rays. I am hopeful that within the next few years wireless plants will be installed for the purpose of illuminating the oceans. The project is perfectly feasible; if carried out it will contribute more than any other provision to the safety of property and human lives at sea. The same plant could also produce stationary electrical waves and enable ships to get any time accurate bearings and other valuable practical data, thus making the present means unnecessary. It could also be used for time signaling and many other such purposes.

In the great departments of electric light and power great opportunities are offered through the introduction of many kinds of novel devices which can be attached

to the circuits at convenient hours to equalize the loads and increase the revenues from the plants. I myself have knowledge of a number of new appliances of this kind. The most important of them is probably an electrical ice machine which obviates entirely the use of dangerous and otherwise objectional chemicals. The new machine will also require no attention and will be very economical in operation. In this way refrigeration will be effected very cheaply and conveniently in every household.

An interesting fountain, electrically operated, has already been brought out. It will very likely be extensively introduced, and will afford an unusual and pleasing sight in squares, parks, and hotels.

Cooking devices for all domestic purposes are now being made, and there is a large demand for practical designs and suggestions in this field, and for electric signs and other attractive means of advertising which can be electrically operated. Some of the effects which it is possible to produce by electric currents are wonderful and lend themselves to exhibitions. There is no doubt that much can be done in this direction. Theatres, public halls, and private dwellings are in need of a great many devices and instruments for convenience, and offer ample opportunities to ingenious and practical inventors.

Great improvements are also still possible in telegraphy and telephony. The use of a new receiving device, the sensitiveness of which can be increased almost without limit, will enable us to telephone through aerial lines or cables of any length by reducing the necessary working current to an infinitesimal value. This invention will enormously extend the wireless transmission of intelligence in all its departments.

The next art to be introduced is that of picture transmission telegraphically. Existing apparatus will be used. This idea of telegraphing or telephoning pictures was arrived at long ago, but practical difficulties have hampered commercial realization. There have been promising experiments, and there is every reason to believe that success will soon be achieved. Another valuable invention will be a typewriter electrically operated by the human voice. This advance will be of the utmost value, as it will do away with the operator and save a great deal of labor and time in business offices.

Many municipal improvements based on the use of electricity are soon to be introduced. There will be smoke annihilators, dust absorbers, ozonizers, sterilizers of water, air, food, and clothing, and accident preventers on streets, elevated roads, and in subways. It will become next to impossible to contract diseases from germs or get hurt in the city. Country folk will go to town to rest and get well.

Electrotherapy is another great field in which there are unlimited possibilities for the application of electricity. High-frequency currents especially have a great future. The time is bound to come when this form of electrical energy will be on tap in every private residence. It is possible that we may be able to do away with the customary bath. The cleaning of the body can be instantaneously effected simply by connecting it to a source of electric energy of very high potential, which will result in the throwing off of dust or any small particles adhering to the skin. Such a bath, besides being dry and time-saving would also be of beneficial therapeutic influence. New electric devices that will be a blessing to the deaf and blind are coming.

Electrical instruments will soon become an important factor in the prevention of crime. In court proceedings electric evidence can be made decisive. It will, no doubt, be possible before very long to flash any image formed in the mind on a screen and make it visible to a spectator at any place desired. The perfection of this sort of reading thought will create a revolution for the better in all our social relations. It is true that cunning lawbreakers will avail themselves of the

same means to further their nefarious business.

The present international conflict is a powerful stimulus to invention of destructive devices and implements. An electric gun will soon be brought out. The wonder is that it was not invented long ago. Dirigibles and aeroplanes will be furnished with small electric generators of high tension, from which the deadly currents will be conveyed through thin wires to the ground. Battleships and submarines will be provided with electric and magnetic feelers so delicate that the approach of any body under water or in darkness may be easily detected. Torpedoes and floating mines will direct themselves automatically and without fail get in fatal contact with the object to be destroyed - in fact, these are almost in sight. The art of telautomatics, or wireless control of automatic machines at a distance, will play a very important role in future wars and, possibly, in the later phases of the present one. Such contrivances, which act as if endowed with intelligence, may take the shape of aeroplanes, balloons, automobiles, surface, or underwater boats, or any other form according to the requirement in each special case. They will have far greater ranges and will be much more destructive than the implements now employed. I believe that the telautomatic aerial torpedo will make the large siege gun, on which so much dependence is now placed, utterly obsolete.

New York Herald
April 15, 1917

NIKOLA TESLA TELLS OF COUNTRY'S WAR PROBLEMS

Needs in Aerial and Naval Spheres and Means for Combating Hostile Attack Described - Numerous Devices of American Invention Already Exist - Others Required

By Nikola Tesla

The conquest of elements, annihilation of distance in the transmission of force and numerous other revolutionary advances have brought us face to face with problems new and unforeseen. To meet these is an imperative necessity rendered especially pressing through the struggle which is now being waged between nations on a stupendous scale unprecedented in history.

This country, finding it impossible to remain an inactive witness of medieval barbarism and disregard of sacred rights, has taken up arms in a spirit broad and impartial and in the interest of humanity and peace. Its participation will be absolutely decisive as regards the final result, but those who expect a speedy termination of the conflict should undeceive themselves.

War, however complex, is essentially a mechanical process, and, in conformity with a universal principle, its duration must be proportionate to the masses set in motion. The truth of this law is borne out by previous records, from which it may be calculated that, barring conditions entirely out of the ordinary, the period should be from five to six years.

Great freedom of institutions, such as we are privileged to enjoy, is not conducive to safety. Militarism is objectionable, but a certain amount of organized discipline is indispensable to a healthy national body. Fortunately, the recognition of this fact has not come too late, for there is no immediate danger, as alarmists would make us believe. The geographical position of this country, its vast resources and wealth, the energy and superior intelligence of its people, make it virtually unconquerable.

We Would Win in the End.

There is no nation to attack us that would not be ultimately defeated in the attempt. But events of the last three years have shown that a combination of many inimical powers is possible, and for such an emergency the United States is wholly unprepared. The first efforts must therefore be devoted to the perfection of the best plea for national protection. This idea has taken hold of the minds of people and great results may be expected from its creative imagination fired by this occasion, such as may in a larger measure recompense for the awful wastage of war.

While the chief reliance in this perilous situation must be placed on the army and navy, it is of the greatest importance to provide a big fleet of aeroplanes and dirigibles for quick movement and observation; also a great number of small high speed craft capable of fulfilling various vital duties as carriers and instruments of defence. These, together with the wireless, will be very effective against the U-boat, of which the cunning and scientific enemy has made a formidable weapon, threatening to paralyze the commerce of the world.

As the first expedient for breaking the submarine blockade, the scheme of employing hundreds of small vessels, advanced by Mr. W. Denman, chairman of the United States Shipping Board, is a most excellent one, which cannot fail to succeed. Another measure which will considerably reduce the toll is to use every possible means for driving the lurking enemy far out into the sea, thus extending the distance at which he must operate and thereby lessening his chances. But a perfect apparatus for revealing his presence is what is most needed at this moment.

Several Devices Known.

A number of devices, magnetic, electric, electro-magnetic or mechanical, more or less known, are available for this purpose. In my own experience it was demonstrated that the small packet boat is capable of affecting a sensitive magnetic indicator at a distance of a few miles. But this effect can be nullified in several ways. With a different form of wireless instrument devised by me some years ago it was found practicable to locate a body of metallic ore below the ground, and it seems that a submarine could be similarly detected.

Sound waves may also be resorted to, but they cannot be depended upon. Another method is that of reflection, which might be rendered practicable, though it is handicapped by experimental difficulties well nigh insuperable. In the present state of the art the wireless principle is the most promising of all, and there is no doubt that it will be applied with telling effect. But we must be prepared for the advent of a large armored submarine of great cruising radius, speed and destructive power which will have to be combatted in other ways.

For the time being no effort should be spared to develop aerial machines and motor boats. The effectiveness of these can be largely increased by the use of a turbine, which has been repeatedly referred to in the HERALD and is ideally suited for such purposes on account of its extreme lightness, reversibility and other mechanical features.

MINUTES OF THE ANNUAL MEETING OF THE AMERICAN INSTITUTE OF ELECTRICAL ENGINEERS, HELD AT THE ENGINEERING SOCIETIES BUILDING, NEW YORK CITY, FRIDAY EVENING, MAY 18, 1917.

PRESENTATION OF THE EDISON MEDAL TO NIKOLA TESLA.

President Buck called the meeting to order at 8:30 o'clock.

THE PRESIDENT: As you know, gentlemen, this is the Annual Meeting of the Institute, and the first thing on the program will be the presentation of the Report of the Board of Directors by our Secretary, Mr. Hutchinson.

SECRETARY HUTCHINSON: The annual report of the Institute for the year has been printed and distributed, and it is not my intention to take the time to read it. It consists of a brief resume of the activities of the institute for the entire year, and includes abstracts of the reports of the various committees.

(Secretary Hutchinson then abstracted the Report of the Board of Directors.)

THE PRESIDENT: Gentlemen, the next order of business of the evening will be the announcement of the election of officers and managers for the coming year. The report of the Tellers will be presented by the Secretary, Mr. Hutchinson.

Secretary Hutchinson then presented the report of the Tellers, which showed elections as follows:

President:	W. W. Rice, Jr.
Vice-Presidents:	Frederich Bedell, John H. Finney, A. S. McAllister
Managers: (Term expiring July 31, 1921)	Walter A. Hall, E. H. Martindale, William A. DelMar, Wilfred Sykes
Treasurer:	George A. Hamilton

(The president then declared the foregoing-named gentlemen as duly elected officers and managers of the Institute as indicated.)

THE PRESIDENT: It is our privilege from time to time to honor those in the electrical profession who have rendered conspicuous service towards this advance. We have the pleasure this evening of so honoring Mr. Nikola Tesla. Dr. Kennelly, who is Chairman of the Edison Medal Committee, will tell us what the Edison Medal is and what it stands for. I take pleasure in introducing Dr. A. E. Kennelly.

DR. A. E. KENNELLY: Mr. President, Ladies and Gentlemen: It is my privilege to say a few words to you upon the origin and purpose of the Edison Medal. First of all, many people suppose that the Edison Medal is a medal presented by Mr. Edison. That is a mistake. Mr. Edison has been so busy during his life receiving medals that he has not time for the delivery of any. The Edison Medal owes its existence to the action of a group of his admirers who in a very remarkable Deed of Gift, a printed copy of which I have here, have set apart a fund for the purpose of the annual award of a medal for meritorious achievement in the electrical science and art. This deed of gift originally recited, in 1904, that the medal should be annually awarded for the best graduating thesis by the students of electrical engineering in the United States and Canada, but in the years that elapsed between 1904 and 1908, I think I am correct in saying that there were no successful candidates, at least for the medal under those terms, although there may have been many aspirants. It is

supposed that the dignity of the medal and the junior character of the tyros restrained them in their modesty from making proper application.

Be that as it may, finding that the applicants held back under the original terms of the deed of gift, the matter was taken up further and the original body of men redrafted the deed and placed it in the hands of the American Institute of Electrical Engineers to award the medal, under the choice of a Committee, annually, for meritorious achievement, as indicated, to any resident of the United States, its dependencies, or Canada, during each administration year. The monument which they raised to Mr. Edison by their act is, I think you will admit, one of the most wonderful that has ever been raised to any scientist.

The Deed of Gift says that there shall be twenty-four members appointed by the American Institute of Electrical Engineers, sixteen from the membership at large, three ex officio members, the President, Secretary and Treasurer, and the balance from the Board of Directors.

Every year the medal is due to be awarded. There have been already six medals awarded, not counting the medal which is to be awarded to-night, and the recipients of these medals have been Elihu Thomson, Frank J. Sprague, George Westinghouse, William Stanley, Charles F. Brush, Alexander Graham Bell. I think you will say that is a fitting selection for the galaxy of names that we look forward to in the future, all of them, in honoring Mr. Edison's achievements, which have been so noteworthy, that every household in the land holds his name as a cherished household word. We may look forward to a time say a thousand years hence, when, like this evening, the American Institute of Electrical Engineers, or its successors or assigns, shall be convoked, and at which the medal of the year will be awarded to its One Thousand and Seventh recipient, and all that long galaxy of names will represent those individuals who have contributed to the recognition of the achievements of Mr. Edison and his gift to humanity.

In addition to what this deed of gift shows in honor of Mr. Edison himself, there is, of course, the very great honor that it bestows upon the recipient. The Deed of Gift says there shall be twenty-four jurors, which you see is twice the number of jurors that is allowed in the palladium of our liberties, but whereas the jurors of ordinary life convict by unanimous vote, the twenty-four jurors of the Edison Medal convict, at least, by a two-thirds vote, so I think I am correct in saying that their convictions have hitherto been entirely unanimous, and in this particular case I can certainly declare that it has been unanimous.

The galaxy of names that will be produced and has already been produced under this deed of gift will be great and noteworthy. It will not be necessary to look into a "Who's Who" to see who has been great and notorious and worthy of merit in electrical science and art. The historian of the future will simply say - "Give me the list of the Edison Medallists."

This deed of gift is also wonderful in other respects. It has marvelous flexibility and marvelous rigidity in certain directions. It provides for the possibility of a change of personnel, a change of procedure and a change of administration as time and things may change. It only makes one rigid restriction, and that is that the name "Edison Medal" shall never be changed. Times may change and persons and institutions, the Institute itself may go out of existence, and there is provided machinery whereby if the Institute should say it is tired, or it has gone out of existence, or can no longer administer the medal, that the five oldest universities of the country, maintaining a course in electrical engineering, shall be able to place the administration of the medal by their vote in the hands of some new institution, so you see that this is a very wonderful Deed of Gift that I have the honor of bringing to your notice here this evening in connection with the bestowal of this medal. Another great advantage that the medal presents is that its

recipient shall be alive, that is to say he must not only have been convicted of great merit and meritorious achievement, but he must also have escaped being run over by automobiles up to the time of the presentation. That represents a great advance over those methods of awarding distinction which depend upon the demise of the individual. You know somebody has said that a great statesman is a successful politician who is dead, but we may say that the Edison Medallist is a great electrician who is alive, and you know it is wonderful how little is known sometimes about a man's demise, however much may be known about his work. The other day I met a negro in the South, and I happened to mention Washington, and what was done by George Washington who died so many years ago, and he said, "For de Lawd's sake, I doant even heard the man was sick." So you see that even George Washington, no matter how meritorious he might have been in electrical matters, could not possibly be the recipient of an Edison medal.

We have recently received the sad news in this country of the demise of the great English electrical engineer Silvanus P. Thomson, a man who had many admirers and many friends in this country, many students here, a man whose name and work is dear to so many of us, and efforts are now being made to contribute to a fitting memorial for him by the purchase of his library as an appendix to the great library of the British Institution of Electrical Engineers, and a notice is given on page 126 of the May Proceedings of the Institute regarding that movement, and you will find it a very worthy movement. Subscription lists are open to the members of this Institute, as a matter of courtesy, and a matter of recognition, that so many of his friends in this country could be allowed to give some contribution to this great Thomson Memorial. It is a fact, as I dare say many of you know, that the funds for Lord Kelvin's Memorial Window in Westminster Abbey were largely raised in America, more largely, I believe, than they were in England itself. In this case I am led to believe that they do not want the funds so much, as they want the names of sympathizers with the project, the support of those who recognize the work and merit of Silvanus P. Thomson. But how much better it would be if we were presenting a memorial to Silvanus P. Thomson living, as we are able to do in the case of the Edison Medal, than presenting a memorial to Silvanus P. Thomson passed away.

Then one thing more: This deed of gift between its lines suggests a third and by no means least important purpose, and that is a safeguard, lest we forget. We in this time and of this continent, particularly we of the electrical profession, with our faces ever turned to the rising sun, are so apt to forget that there has been a preceding night of trouble, difficulty and dismay, and that the tools of our trade which lie to our hand were only secured by hard work and toil against all sorts of distress and discouragements. The Edison Medal is our means for reviving your memories of the past and pointing out that the things we look upon as the sunshine of heaven now have been arrived at by the hard work, the inspiration, or, as Edison himself would say, the perspiration of those who have worked in the past.

We remember that beautiful book, "The Twins", where Budge and Toddy the children always insisted at all times of the day and night to see the wheels go 'round and have their father's watch opened for them. The medallist to-night was a man who saw in his mind wheels going around when there was no means of getting alternating current motors to rotate, when the alternating current would do everything but make wheels go 'round, and he devised the rotating magnetic field so prophetically in his mind's eye that the rotating magnetic wheel would set wheels going 'round all over the land and all over the world, and the vision is carried out, and we recognize that vision here, and the Medal is partly as a reminder that we should not forget the fact, that the medallist also made the phenomenon of high frequency known to us all practically for the first time, and that what he showed was a revelation to science and art unto all time.

For this third purpose the Edison Medal has been created, and we may look far

forward into the future and see it given year after year for, let us hope, a thousand years from now, in the year 2917, to witness the ceremony which we may well expect will be furnished at that time. (Applause)

THE PRESIDENT: Dr. Kennelly has referred to the struggles of the past, and we are very fortunate in having with us to-night one who was associated with Mr. Tesla in his struggles of the past. Gentlemen, I want to introduce to you Mr. Charles A. Terry, who will tell us something about these struggles and the early work of Mr. Tesla, for which we assign to him the Medal to-night.

CHARLES A. TERRY: Mr. Kennelly spoke of the thousandth award of the Medal. I think there is a peculiar significance in the fact that Mr. Tesla is to receive the seventh medal - the seventh in most calculations is considered a most excellent number to have.

The convolutions of the brain of one man impel him to paint upon canvas the visions of his soul; another conceives beauty of form which he must express in plastic art or in architectural structure; others are driven by an inner force to devote their lives to the discovery of the secrets of unexplored regions of the earth, or to search out the mysteries of the stars; some find themselves compelled by an irresistible desire to learn through archeological research the forgotten achievements of ancient races; still others seek to ascertain and formulate the physical laws which govern the processes of nature, and men with other talents find themselves urged by a like persistent force to devise and disclose new means whereby those laws may be utilized for the further benefit of mankind.

It is this God-given desire to accomplish and to give, that has produced the Michelangelos, the Galileos, the Sir Christopher Wrens, the Livingstons, Newtons, Franklins, Westinghouses, Edisons and scores of other makers of history; men whose names we retain in affectionate remembrance, because they earnestly responded to the call from within and by patient toil conceived thoughts and discovered things of value which they promulgated for the benefit of their fellow men.

Although hope of reward may and properly should exist as an added impulse to such endeavors, the chiefly effective force compelling to the long hours of hard work and personal sacrifices of such men is the "I must" which speaks from within the soul, and with our truly great men the desire for reward is better satisfied by a consciousness of achieving their aims and by the just commendation of their fellows than by material gain, except insofar as the latter may aid in the further advancement of their tasks.

Fortunately, men generally are not jealous nor envious of the doers of great deeds and the givers of large benefits, but from the depths of their hearts are grateful and they are satisfied only when evidence of their gratitude can be brought home to the giver.

It is because of this desire to show gratitude to, and appreciation of, one of our fellow members, whose name history will rightly record in the same distinguished class with those we have mentioned that we are gathered to-night.

Twenty-nine years ago this month, there was presented before this Institute, a paper of unusual import. It is entitled "A New System of Alternate Current Motors and Transformers". The author, Nikola Tesla, was then only 31 years of age, and but four years a resident of this country. His early life was spent near his birth-place not far from the Eastern Adriatic Coast. His father a Greek Clergyman and his mother, herself of an inventive mind, secured for their young son a comprehensive training in mathematics, physics and philosophy. At the age of 22 he had completed his studies in engineering at the Polytechnic School in Gratz and also a course in the University of Prague; and in 1881 began his practical work at Budapest. In 1883 he was located in Strasbourg, engaged in completing the lighting of a newly

erected railway station. Shortly after finishing this task he came to the United States. Mr. Tesla's first work in this country was upon new designs of direct current arc and incandescent lighting systems for the Edison Company.

Throughout all these years his desire had been to find an opportunity to demonstrate the truth of a conviction which became fixed in his mind while studying direct current motors in school at Gratz in 1878; the conviction was that it should be possible to create a rotating magnetic field without the use of commutators. While at Strasbourg, Tesla had succeeded in producing the rotation of a pivoted iron disc placed in a coil traversed by alternating currents, a steel bar being projected into the coil in the neighborhood of the disc. His conception of the reason for this rotation at that time was that a lag occurred in the subsidence of the magnetism of both the disc and the steel bar between successive current waves, and that the mutual repulsions caused the disc to revolve. By some fortunate process of reasoning he conceived while in Budapest (in 1882) that by using two or more out-of-phase alternating currents respectively passing through geometrically displaced coils it would be possible to develop his long sought progressively shifting magnetic field.

Lack of funds and facilities for working out his theory compelled still further postponement, but in 1885 Tesla had the good fortune to interest men of means in a direct current arc light which he had devised, and subsequently a laboratory was equipped for him in Liberty Street, New York, and here at last he found opportunity to demonstrate the correctness of his long cherished theory. In 1887 he was able to exhibit to his business associates and to Professor William A. Anthony, whose expert opinion they sought, motors having such progressively shifting fields without the use of commutators, as he had foreseen nine years before.

Having thus demonstrated the correctness of his theory and the feasibility of its application, it remained for Tesla to work out various practical methods of applying the principle, and the rapidity and wonderful way in which he surrounded the entire field of constant speed, synchronous, induction and split-phase motors is beautifully set forth in his paper of May 18th, and in the numerous patents issued May 1st, 1888, and succeeding years, covering the forms of electric motors which have since become the almost universal means for transforming the energy of alternating currents into mechanical energy.

It is somewhat difficult to eliminate from our minds the developments of the past thirty years which have now become every day features of the electrical industry, and to realize the meagreness of the then existing knowledge of alternating current phenomena. The commercial use of alternating current systems of distributions was then scarcely two years old. The Gaulard & Gibbs system of series transformers had been used abroad in a limited way for a slightly longer period but the multiple arc system based upon the so-called "Stanley Rule" which initiated the great development of the present system, was not put in practical operation in the pioneer Great Barrington plant until March 1886. It was then recognized that while the alternating current possessed wonderful possibilities for electrical distribution for lighting purposes, two almost necessary devices were lacking to render it a complete success, one a meter, the other a power motor. Professor Elihu Thomson promptly devised a successful form of meter, the motive portion of which comprised a laminated field and armature, the coils of the latter being periodically close-circuited during revolution by a commutator. To fill the demand for a power motor, however, the most promising device then suggested was a series commutator motor with laminated field and armature cores, but no satisfactory results had been obtained. Such was the situation when Tesla's achievement was announced in the Institute paper to which reference has been made.

His Honor Judge Townsend of the United States Circuit Court, in an opinion

rendered in August, 1900, as the outgrowth of some patent litigation on the Tesla inventions, concisely defines the underlying characteristic of the Tesla motor as follows:

"Tesla's invention, considered in its essence, was the production of a continuously rotating or whirling field of magnetic forces for power purposes by generating two or more displaced or differing phases of the alternating current, transmitting such phases, with their independence preserved, to the motor, and utilizing the displaced phases as such in the motor."

Among the first to recognize the immense importance of Mr. Tesla's motors were Mr. Westinghouse and his advisors, Mr. T. B. Kerr, Mr. Byllesby, Mr. Shallenberger and Mr. Schmid, and in June Mr. Westinghouse secured an option which shortly resulted in the purchase of the patents, thus bringing under one ownership the alternating current transformer system of distribution, and the Tesla motor. It is interesting to here note that Mr. Shallenberger had about two weeks before the publication of the Tesla patents independently devised an alternating current meter, the principle of operation of which was that of the Tesla motor, and whatever might have been Mr. Shallenberger's natural disappointment upon finding himself thus anticipated, he at once recognized that to Mr. Tesla belonged the honor of being the first to solve the great fundamental problem of an alternating current motor. A warm friendship between these two men began at once and continued throughout Mr. Shallenberger's life, and Mr. Tesla rejoiced to accord to Mr. Shallenberger full credit for the latter's brilliant work in producing what is now the standard meter for alternating currents.

As illustrating the generous gentleness of Tesla's character, I wish to here quote from testimony given by him in 1903. Referring to Shallenberger, Tesla said:

"I clearly remember that in the first days when I came to Pittsburgh he took me to lunch at the Duquesne Hotel, and when I told him that I was sorry that I had anticipated him, I saw tears in his eyes. That incident I remember vividly; but what has preceded it I cannot remember now. Perhaps it is because this impression was so vivid that it has destroyed the preceding ones, which were weaker."

It is characteristic of Tesla that he should so deeply regret the disappointments of another.

Owing in a measure to the circumstance that the then prevailing rate of alternation of the alternating current system was 16,000, the commercial introduction of Tesla motors was somewhat retarded during the first few years, that rate being found less adapted to the motor work than a lower rate. Today, however, wherever alternating current systems are used Tesla motors abound. Without such motors the alternating current system would have remained seriously restricted in its use.

Before passing to a consideration of other of Tesla's activities, it will be appropriate to refer again to the opinion of Judge Townsend, from which I quote the following:

"The Tesla discovery for which these patents were granted revolutionized the art of electrical power transmission, as well demonstrated in the record from both judicial and scientific standpoints."

In the closing passage of the opinion, Judge Townsend pays further tribute to Tesla in the following words:

"It remained to the genius of Tesla to capture the unruly, unrestrained, and hitherto opposing elements in the field of nature and art and to harness them to draw the machines of man. It was he who first showed

how to transform the toy of Arago into an engine of power, the "Laboratory experiment" of Baily into a practically successful motor, the indicator into a driver. He first conceived the idea that the very impediments of reversal in direction, the contradictions of alternations, might be transformed into power-producing rotation, a whirling field of force.

What others looked upon as only invincible barriers, impassable currents, and contradictory forces, he brought under control and by harmonizing their directions taught how to utilize in practical motors in distant cities the power of Niagara."

Imagination developed to a high degree is a marked characteristic of all great inventors, so it is of our great poets, artists, philosophers, generals, and, in fact, of all great originators of thought and motion. The power to picture in the mind things not yet existent is an underlying characteristic of most great men. But imagination to be effective must be combined with a just sense of proportion, a logical appreciation of limitations, and a capacity for unremitting application. Mr. Tesla combines these qualities in a marked degree, and particularly does he possess the faculty of projecting his thought far into unexplored regions, not only of science but of philosophy. His passion for searching out the ultimate is charmingly evidenced by the following extract from his lecture before this Institute at Columbia College, May 20th, 1891;

"In how far we can understand the world around us is the ultimate thought of every student of nature. The coarseness of our senses prevents us from recognizing the ulterior construction of matter, and astronomy, this grandest and most positive of natural sciences, can only teach us something that happens, as it were, in our immediate neighborhood; of the remoter portions of the boundless universe, with its numberless stars and suns, we know nothing. But far beyond the limit of perception of our senses the spirit still can guide us, and so we may hope that even these unknown worlds - infinitely small and great - may in a measure become known to us. Still, even if this knowledge should reach us, the searching mind will find a barrier, perhaps forever unsurpassable, to the true recognition of that which seems to be, the mere appearance of which is the only and slender basis of all our philosophy.

Of all the forms of nature's immeasurable, all-pervading energy, which, ever and ever changing and moving, like a soul animates the inert universe, those of electricity and magnetism are perhaps the most fascinating."

The impress made upon the world by the deeds of a great inventor cannot be measured by the number of patents which he has received nor by the monetary reward secured nor by the mere exploitation of his name. Often his greatest gifts are in the form of inspiring contributions to the literature, filled with suggestions of lines of thought which lead others to work in untried fields. This is especially true of a series of lectures delivered by Mr. Tesla upon the subject of high frequency, high potential currents. The first of the series was given at Columbia College in 1891, before this Institute. During 1892 and 1893 this lecture with additional data and experiments was repeated in London, Paris, Philadelphia and St. Louis.

Referring to an interesting interview with Mr. Tesla appearing in a New York daily in 1893 regarding the St. Louis lecture the Editor of the Electrical World says:

"Mr. Tesla, in his own graceful way, tells the story of his life and the history of some of his more important inventions. Perhaps there is no living scientist in whose life and work the general public takes a deeper

interest, especially in this country."

Tesla's fundamental purpose was to publish the results of an extended research and of a series of experiments patiently conducted at his laboratory and elsewhere through many years. During these lectures he exhibited to the audience numerous experiments displaying striking and instructive phenomena. He also described many novel pieces of apparatus such, for instance, as his high-frequency generator and induction coils and his magnetically quenched arc. Mr. Erskine Murray in his treatise upon Wireless Telegraphy, referring to certain of these early inventions of Tesla says:

"Among many other inventions, made as early as 1893, perhaps the most important to wireless telegraphists is his method of producing long trains of waves of high frequency, and of transforming them to higher voltage. After several unsuccessful attempts he completed an alternator which could be run at 30,000 periods per second, and designed a form of transformer capable of transforming these currents to very high voltage. He also showed that his transformer, or "Tesla coil" as it is usually called nowadays, could transform currents of much higher frequencies than were obtainable from his alternator, even currents of 100,000 or 1,000,000 periods per second, such as are produced by the oscillatory discharge of a Leyden jar."

The London lecture was given under the auspices of the British Institution of Electrical Engineers and because of the intense public interest manifested after its announcement the ample capacity of the Theatre of the Royal Institution was required to accommodate the audience.

At the completion of the lecture Prof. Aytron spoke as follows:

"It is my most pleasing duty to propose a very hearty vote of thanks to our lecturer, who has entertained us, it is true, for two hours, but we would willingly wait for another hour's similar entertainment."

Mr. Fleming in his authoritative book on wireless telegraphy and telephony pays the following tribute:

"In 1892 Nikola Tesla captured the attention of the whole scientific world by his fascinating experiments on high frequency electric currents. He stimulated the scientific imagination of others as well as displayed his own, and created a widespread interest in his brilliant demonstrations.

Amongst those who witnessed these things no one was more able to appreciate their inner meaning than Sir William Crookes."

An article by E. Raverot appearing in the Electrical World of March 26, 1892, closes a review of the Tesla Paris lecture with the following appreciative comment:

"One sees from this lecture the deep interest which the works and discoveries of Mr. Tesla have inspired among physicists since the first appearance of his publication, and it is with great satisfaction that we are able to express the feeling of admiration which his experiments have inspired in us."

In his London lecture delivered in February, 1892, Tesla had occasion to describe a special construction of insulated cable designed to guard against electro-static disturbances, but immediately added the following significant prediction:

"But such cables will not be constructed, for ere long intelligence - transmitted without wires - will throb through the earth like a pulse through a living organism. The wonder is that, with the present state

of knowledge and experiences gained, no attempt is being made to disturb the electrostatic or magnetic condition of the earth and transmit, if nothing else, intelligence."

This was Tesla's prophecy twenty-five years ago.

In his lecture before the National Electric Light Association at St. Louis in March, 1893, Mr. Tesla elaborated certain views regarding the importance of resonance effects in this field and stated:

"I would say a few words on a subject which constantly fills my thoughts and which concerns the welfare of all. I mean the transmission of intelligible signals or perhaps even power to any distance without the use of wires."

He then announced that his conviction had grown so strong that he no longer looked upon the plan of transmitting intelligence as a mere theoretical possibility, and referring to the existing belief of some that telephony to any distance might be accomplished "by induction through the air", concisely set forth his theory as follows:

"I cannot stretch my imagination so far, but I do firmly believe that it is practical to disturb by means of powerful machines the electro-static condition of the earth and thus transmit intelligible signals and perhaps power."

Enlarging upon this theory, he states that, although we have no possible evidence of a charged body existing in space without other oppositely electrified bodies being near, there is a fair probability that the earth is such a body, for by whatever process it was separated from other bodies it must have retained a charge and that the upper strata of the air may be conducting and contain this opposite charge. He further expanded the theory that with proper means for producing electrical oscillations it might be possible to produce electrical disturbances sufficiently powerful to be perceptible by suitable instruments at any point on the Earth's surface. He thus forecast the theory at present accepted by leading scientists as the true basis of wireless telegraphy.

Continuing the same line of thought Mr. Tesla in an interview which appeared in the New York Herald in 1893 said:

"One result of my investigations, the possibility of which has been proven by experiment, is the transmission of energy through the air. I advanced that idea some time ago, and I am happy to say it is now receiving some attention from scientific men.

The plan I have suggested is to disturb by powerful machinery the electricity of the earth, thus setting it in vibration. Proper appliances will be constructed to take up the energy transmitted by these vibrations, transforming them into suitable form of power to be made available for the practical wants of life."

Testifying in a patent suit regarding these early predictions Mr. John Stone Stone, the well-known authority on wireless telegraphy has but recently made the following striking comment:

"I misunderstood Tesla. I think we all misunderstood Tesla. We thought he was a dreamer and visionary. He did dream and his dreams came true, he did have visions but they were of a real future, not an imaginary one. Tesla was the first man to lift his eyes high enough to see that the rarified stratum of atmosphere above our earth was destined to play an important role in the radio telegraphy of the future, a fact which had to obtrude itself on the attention of most of us before we saw it. But

Tesla also perceived what many of us did not in those days, namely, the currents which flowed away from the base of the antenna over the surface of the earth and in the earth itself."

Seldom is it that an art springs into being through the efforts of one man alone, but rather as a growth to which many have contributed. This is peculiarly true of the wireless art, and without detracting in the slightest from the honor which is justly due to those who have brought the system to its present wonderful efficiency, it is just to accord to Tesla highest praise not alone for his exposition of principles as set forth in his lectures but also for the more definitive work which followed, much of which is evidenced by his many patents dealing with the wireless art.

Before leaving this branch of Tesla's work, I wish to quote again from the testimony of Mr. Stone, presenting his view of the indebtedness of the wireless art to Tesla:

"Some of those whose work or whose writings during that early period must be noted are Nikola Tesla, Prof. Elihu Thomson, Prof. M. I. Pupin, Prof. Lodge, Prof. Northrup, Prof. Pierce, Hutin & Leblanc, Mr. Marconi and myself. Among all these, the name of Nikola Tesla stands out most prominently. Tesla, with his almost preternatural insight into alternating current phenomena that had enabled him some years before to revolutionize the art of electric power transmission through the invention of the rotary field motor, knew how to make resonance serve, not merely the role of microscope to make visible the electric oscillations, as Hertz had done, but he made it serve the role of a stereopticon to render spectacular to large audiences the phenomena of electric oscillations and high frequency currents.*****He did more to excite interest and create an intelligent understanding of these phenomena in the years 1891-92-93 than any one else, and the more we learn about high frequency phenomena, resonance and radiation today, the nearer we find ourselves approaching what we at one time were inclined, through a species of intellectual myopia, to regard as the fascinating but fantastical speculations of a man who we are now compelled, in the light of modern experience and knowledge, to admit was a prophet. He saw to the fulfillment of his prophesies and it has been difficult to make any but unimportant improvements in the art of radio-telegraph without traveling part of the way at least, along a trail blazed by this pioneer who, though eminently ingenious, practical and successful in the apparatus he devised and constructed, was so far ahead of his time that the best of us then mistook him for a dreamer."

Another well recognized wireless authority, Professor Slaby in a personal letter to Tesla took occasion to say:

"I am devoting myself since some time to investigations in wireless telegraph, which you have first founded in such a clear and precise manner. It will interest you, as father of this telegraph, to know, etc."

Throughout Tesla's work with high potential currents he had persistently in mind the wireless transmission of power in large quantities. It was in the furtherance of this line of investigation that he expended large amounts of money and years of labor at Wardenclyffe, Long Island, and at Telluride, Colorado. Late in 1914 he secured a patent upon an application filed twelve years before upon an apparatus for transmitting electric energy with which he hopes to be able to transmit unlimited power with high economy to any distance without wires. While as yet these efforts have not resulted in commercial exploitation, the future may prove that his dream of thus transmitting energy in substantial amounts is of that class which

in time come true, as in the case of his dream of wireless telegraphy.

Another use to which Tesla adapted the results of his high frequency investigations was the control of the movements of torpedoes and boats. In 1898 he patented such an apparatus and also built and successfully operated such a craft. The movements of the propelling engine, the steering and other mechanisms were controlled wirelessly from the shore or other point through a distance of two miles. Apparently this, like some of his other inventions, was ahead of its time. Tesla, however, evidenced his entire faith in the future of the apparatus in an interview which appeared in 1898 from which I quote:

"But I have no desire that my fame should rest on the invention of a merely destructive device, no matter how terrible. I prefer to be remembered as the inventor who succeeded in abolishing war. That will be my highest pride. But there are many peaceful uses to which my invention can be put, conspicuously that of rescuing the shipwrecked.

It will be perfectly feasible to equip our lifesaving stations with life cars, or boats, directed and controlled from the shores, which will approach stranded vessels and bring off the passengers and crews without risking the lives of the brave fellows who are now forced to fight their way to the rescue through the raging surf. It may also be used for the propulsion of pilot boats, for carrying letters or provisions or instruments to inaccessible regions*****."

On March 12th, 1895, Mr. Tesla met with a disastrous loss by the destruction of his laboratory at 33 and 35 South 5th Avenue, New York. In the Electrical Review of March 20th, 1895, there is published an interview with Mr. Tesla regarding this fire. In it he says:

"I am congratulating myself all the time it is no worse. I begin all over again, but I have the knowledge and experience of what has gone before, and fortunately I was able to show with completed apparatus that my ideas and theories are correct. Had the fire occurred a few months ago I should have been robbed of the opportunity of many highly successful demonstrations."

In his laboratory were stored a vast quantity of old models and trial apparatus with which he would have been unwilling to part for any amount of money. He further states that he was at the time engaged upon four main lines of work and investigation: his oscillator, and improved method of electric lighting, the transmission of intelligence without wires, and, an investigation relating to the nature of electricity. Mr. Tesla deeply appreciated the expressions of sympathy received from his many friends and with unabated zeal applied himself to a continuation of the work thus unfortunately interrupted.

Another field of investigation in which Mr. Tesla has contributed valuable material is related to the Roentgen Ray. In the Electrical Review of March and April, 1896, there appeared a number of communications from Mr. Tesla which while giving full credit to Roentgen for his magnificent discovery made public much additional data derived from his own careful experiments in this line of research. From an editorial in the Electrical Review of March 18th, 1896, the following is quoted:

"The announcement of Nikola Tesla's achievements in the new art first published in the Electrical Review of March 11th, in the author's own modest language has added fresh impetus to the work in this direction. His disruptive discharge coil has been universally used where the best results in radiography have been obtained, and his two marked improvements, namely, the single electrode tube and his method of rarefaction, promise great results. Other important points about Tesla's work are

the fine details he has obtained in his radiographs, the great distance at which the radiographs have been made, and brief time of exposure."

and again:

"Mr. Tesla is pursuing quietly his work and giving all credit to Roentgen; and it is significant, we think, that the first radiograph he produced in his laboratory was the name of the discoverer. We wish that such courtesies among scientists would always be practiced."

Mr. J. Mount Bleyer commenting upon these investigations said:

"The results obtained by Tesla are simply marvelous, but are just what I expected."

Among the many other inventions to which Mr. Tesla has devoted much time and energy may be mentioned a thermo-magnetic motor and a pyro-magnetic generator, anti-sparking dynamo brush and commutator, auxiliary brush regulation of direct current dynamos, uni-polar dynamos, mechanical and electrical oscillators, electro-therapeutic apparatus, the oxidation of nitrogen by high frequency currents, and an electrolytic registering meter. The last named device was based upon an exceedingly interesting theory. The current to be measured was passed through two parallel conductors arranged in series. The current established a difference of potential between these conductors proportional to the strength of the current passing. This results in a transference of the metal from one conductor to the other, thereby decreasing the resistance of one and increasing that of the other. From such variations in resistance of one or both, the current energy expended is computed.

One other line of endeavor entirely outside of electricity to which Tesla has given much attention is the development of a bladeless steam turbine in which the friction of the passing steam as distinguished from its direct impact is availed of. The steam is admitted between plain parallel rotating discs and passing spirally from the circumference toward the axial center imparts energy to the discs. Such a turbine can be run at exceedingly high temperatures, is readily reversible and having no blades is extremely simple and free from liability to accidental derangement. With great ingenuity Tesla has succeeded in producing such machines of considerable power and having exceedingly interesting characteristics. It is to be hoped that with his indefatigable zeal Tesla will soon succeed in perfecting the commercial application of this invention.

It is not possible in this brief survey even to touch upon many of the lines of Mr. Tesla's activities, but we must content ourselves with this inadequate presentation of typical evidences of the fascinating genius of this man whom we delight to welcome as a citizen of our country - the country which he twenty-five years ago adopted as his own - the country of which he once said:

"When I arrived upon your hospitable shores I eagerly applied myself to work and to learn, and I have persevered in that course. If I have made any special success in this country, I attribute it largely to a feature which is characteristic of both the English and American races; that is, their keen and generous appreciation of any work that they think is good."

Mr. Tesla, we would indeed be woefully lacking in the attributes which you so kindly ascribe to us were we not most cordially appreciative of your work, work which we know is good.

THE PRESIDENT: Gentlemen, we are fortunate in having with us to-night another man who has been familiar with Mr. Tesla's work for many years and can tell us something further about his work. I introduce Mr. B. A. Behrend.

B. A. BEHREND: Mr. Chairman: Mr. President of the American Institute of Electrical Engineers: Fellow Members: Ladies and Gentlemen:

BY AN EXTRAORDINARY COINCIDENCE, it is exactly twenty-nine years ago, to the very day and hour, that there stood before this Institute Mr. Nikola Tesla, and he read the following sentences:

"To obtain a rotary effort in these motors was the subject of long thought. In order to secure this result it was necessary to make such a disposition that while the poles of one element of the motor are shifted by the alternate currents of the source, the poles produced upon the other elements should always be maintained in the proper relation to the former, irrespective of the speed of the motor. Such a condition exists in a continuous current motor; but in a synchronous motor, such as described, the condition is fulfilled only when the speed is normal.

"The object has been attained by placing within the ring properly subdivided cylindrical iron core wound with several independent coils closed upon themselves. Two coils at right angles are sufficient, but a greater number may be advantageously employed. It results from this disposition that when the poles of the ring are shifted, currents are generated in the closed armature coils. These currents are the most intense at or near the points of the greatest density of the lines of force, and their effect is to produce poles upon the armature at right angles to those of the ring, at least theoretically so; and since this action is entirely independent of the speed - that is, as far as the location of the poles is concerned - a continuous pull is exerted upon the periphery of the armature. In many respects these motors are similar to the continuous current motors. If load is put on, the speed, and also the resistance of the motor, is diminished and more current is made to pass through the energizing coils, thus increasing the effort. Upon the load being taken off, the counter-electromotive force increases and less current passes through the primary or energizing coils. Without any load the speed is very nearly equal to that of the shifting poles of the field magnet.

"It will be found that the rotary effort in these motors fully equals that of the continuous current motors. The effort seems to be greatest when both armature and field magnets are without any projections."

Not since the appearance of Faraday's Experimental Researches in Electricity has a great experimental truth been voiced so simply and so clearly as this description of Mr. Tesla's great discovery of the generation and utilization of polyphase alternating currents. He left nothing to be done for those who followed him. His paper contained the skeleton even of the mathematical theory.

Three years later, in 1891, there was given the first great demonstration, by Swiss engineers, of the transmission of power at 30,000 volts from Aauffen to Frankfurt by means of Mr. Tesla's system. A few years later this was followed by the development of the Cataract Construction Company, under the presidency of our member, Mr. Edward D. Adams, and with the aid of the engineers of the Westinghouse Company. It is interesting to recall here to-night that in Lord Kelvin's report to Mr. Adams, Lord Kelvin recommended the use of direct current for the development of power at Niagara Falls and for the transmission to Buffalo.

The due appreciation or even enumeration of the results of Mr. Tesla's invention is neither practicable nor desirable at this moment. There is a time for all things. Suffice it to say that, were we to seize and to eliminate from our industrial world the results of Mr. Tesla's work, the wheels of industry would cease to turn, our

electric cars and trains would stop, our towns would be dark, our mills would be dead and idle. Yea, so far reaching is this work, that it has become the warp and woof of industry.

The basis for the theory of the operating characteristics of Mr. Tesla's rotating field induction motor, so necessary to its practical development, was laid by the brilliant French savant, Prof. Andre Blondel, and by Prof. Kapp of Birmingham. It fell to my lot to complete their work and to coordinate, - by means of the simple "circle diagram," - the somewhat mysterious and complex experimental phenomena. As this was done twenty-one years ago, it is particularly pleasing to me, upon the coming of age of this now universally accepted theory, - tried out by application to several million horse power of machines operating in our great industries, - to pay my tribute to the inventor of the motor and the system which have made possible the electric transmission of energy. HIS name marks an epoch in the advance of electrical science. From THAT work has sprung a revolution in the electrical art.

We asked Mr. Tesla to accept this medal. We did not do this for the mere sake of conferring a distinction, or of perpetuating a name; for so long as men occupy themselves with our industry, his work will be incorporated in the common thought of our art, and the name of Tesla runs no more risk of oblivion than does that of Faraday, or that of Edison.

Nor indeed does this Institute give this medal as evidence that Mr. Tesla's work has received its official sanction. His work stands in no need of such sanction.

No, Mr. Tesla, we beg you to cherish this medal as a symbol of our gratitude for the new creative thought, the powerful impetus, akin to revolution, which you have given to our art and to our science. You have lived to see the work of your genius established. What shall a man desire more than this? There rings out to us a paraphrase of Pope's lines on Newton:

Nature and Nature's laws lay hid in night
God said, 'Let Tesla be,' and all was light.

THE PRESIDENT: It is easy, I think, for engineers and scientists to take for granted things that have been done in years past. When we sit under an apple tree and see the apples fall, it is an obvious phenomenon of nature. We can understand the laws of gravitation, but to Sir Isaac Newton, many years ago, this phenomenon, which to us to-day is so simple, helped him to an act of creative imagination of the most extraordinary kind.

So, later on, the phenomenon of electromagnetic induction, which to us to-day has become a matter of second nature, to Faraday was an act of the most extraordinary creative imagination.

Thirty years ago when Mr. Tesla was doing his very great work, we sometimes forget the conditions of electrical engineering which prevailed at that time. Direct-current or continuous current was universally used, and the conceptions of electrical engineers with respect to electric currents were all unidirectional, so to speak. We had not arrived at that conception of currents which went first in one direction and then in another, to say nothing of electrical currents which differed by phase relations, and the work of Nikola Tesla at that time in his great conception of the rotary field seems to me one of the greatest feats of imagination which has ever been attained by human mind. To-day we take the rotary field motor, the rotary field transmission, as a matter of course, because we have become used to it, and we forget what it required of the human intellect to create it thirty or thirty-five years ago.

At the time the great Niagara Falls enterprise was instituted, we were under the direct-current regime. As Mr. Behrend says, such a great authority on electrical engineering as Lord Kelvin, and also Mr. Edison, recommended direct-current for

transmission of energy from Niagara Falls to Buffalo, and as a system for universal use in their great waterpower development. I think we all realize to-day where we should be at the present time if direct-current had been used in the development of that enterprise. There would have been a radiating copper mine running out from Niagara Falls which would have wrecked the enterprise in the first year of its existence. Mr. Tesla came along with his great mind and at the psychological moment devised the principle which made that enterprise a success, and made hundreds of other enterprises all over the world an equal success. We owe him the greatest possible debt of gratitude for what he has done for electrical engineers.

And so again, in another field of endeavor in which he was most conspicuous, that of high voltage and high frequency alternating-current, he devised and discovered phenomena which were entirely new to electrical engineers, and he introduced to the world the conception of alternating-current as being elastic or oscillating media. The direct-current engineers at the time never thought of the electric current being something that could oscillate, and Mr. Tesla showed it could, and he also showed many of the phenomena which resulted from oscillating currents. From his work followed the great work of Roentgen, who discovered the Roentgen rays, and all that work which has been carried on throughout the world in the following years by J. J. Thompson and others, which has really led to the conception of modern physics. His work, as has been stated, antedated that of Marconi and formed the basis of wireless telegraphy, which is one of the most scientific applications of the present day, and so on throughout all branches of science and engineering we find from time to time some important evidence of what Tesla has contributed to the sciences and engineering of the present day. So, Mr. Tesla, you hear to-night the many compliments which have been paid to you, but they are not bouquets merely cast for the adornment of the occasion - they have been given with the sincere appreciation of the electrical profession, and we give this medal to you in recognition of this, with full appreciation of what you have done for us, and with great hope that you may continue to contribute to our profession in the future. (Great applause)

NIKOLA TESLA: Mr. President, Ladies and Gentlemen. - I wish to thank you heartily for your kind sympathy and appreciation. I am not deceiving myself in the fact, of which you must be aware, that the speakers have greatly magnified my modest achievements. One should in such a situation be neither diffident nor self-assertive, and in that sense I will concede that some measure of credit may be due to me for the first steps in certain new directions; but the ideas I advanced have triumphed, the forces and elements have been conquered, and greatness achieved, through the co-operation of many able men some of whom, I am glad to say, are present this evening. Inventors, engineers, designers, manufacturers and financiers have done their share until, as Mr. Behrend said, a gigantic revolution has been wrought in the transmission and transformation of energy. While we are elated over the results achieved we are pressing on, inspired with the hope and conviction that this is just a beginning, a forerunner of further and still greater accomplishments.

On this occasion, you might want me to say something of a personal and more intimate character bearing on my work. One of the speakers suggested: "Tell us something about yourself, about your early struggles." If I am not mistaken in this surmise I will, with your approval, dwell briefly on this rather delicate subject.

Some of you who have been impressed by what has been said, and would be disposed to accord me more than I have deserved, might be mystified and wonder how so much as Mr. Terry has outlined could have been done by a man as manifestly young as myself. Permit me to explain this. I do not speak often in public, and wish to address just a few remarks directly to the members of my profession, so that there will be no mistake in the future. In the first place, I come from a very wiry and long-lived race. Some of my ancestors have been centenarians, and one of them lived

one hundred and twenty-nine years. I am determined to keep up the record and please myself with prospects of great promise. Then again, nature has given me a vivid imagination which, through incessant exercise and training, study of scientific subjects and verification of theories through experiment, has become very accurate and precise, so that I have been able to dispense, to a large extent, with the slow, laborious, wasteful and expensive process of practical development of the ideas I conceive. It has made it possible for me to explore extended fields with great rapidity and get results with the least expenditure of vital energy. By this means I have it in my power to picture the objects of my desires in forms real and tangible and so rid myself of that morbid craving for perishable possessions to which so many succumb. I may say, also, that I am deeply religious at heart, although not in the orthodox meaning, and that I give myself to the constant enjoyment of believing that the greatest mysteries of our being are still to be fathomed and that, all the evidence of the senses and the teachings of exact and dry sciences to the contrary notwithstanding, death itself may not be the termination of the wonderful metamorphosis we witness. In this way I have managed to maintain an undisturbed peace of mind, to make myself proof against adversity, and to achieve contentment and happiness to a point of extracting some satisfaction even from the darker side of life, the trials and tribulations of existence. I have fame and untold wealth, more than this, and yet - how many articles have been written in which I was declared to be an impractical unsuccessful man, and how many poor, struggling writers, have called me a visionary. Such is the folly and shortsightedness of the world!

Now that I have explained why I have preferred my work to the attainment of worldly rewards, I will touch upon a subject which will lend me to say something of greater importance and enable me to explain how I invent and develop ideas. But first I must say a few words regarding my life which was most extraordinary and wonderful in its varied impressions and incidents. In the first place, it was charmed. You have heard that one of the provisions of the Edison Medal was that the recipient should be alive. Of course the men who have received this medal have fully deserved it, in that respect, because they were alive when it was conferred upon them, but none has deserved it in anything like the measure I do, when it comes to that feature. In my youth my ignorance and lightheartedness brought me into innumerable difficulties, dangers and scrapes, from which I extricated myself as by enchantment. That occasioned my parents great concern more, perhaps, because I was the last male than because I was of their own flesh and blood. You should know that Serbians desperately cling to the preservation of the race. I was nearly drowned a dozen times. I was almost cremated three or four times and just missed being boiled alive. I was buried, abandoned and frozen. I have had narrow escapes from mad dogs, hogs and other wild animals. I have passed through dreadful diseases - have been given up by physicians three or four times in my life for good. I have met with all sorts of odd accidents - I cannot think of anything that did not happen to me, and to realize that I am here this evening, hale and hearty, young in mind and body, with all these fruitful years behind me, is little short of a miracle.

But my life was wonderful in another respect - in my capacity of inventor. Not so much, perhaps, in concentrated mentality, or physical endurance and energy; for these are common enough. If you inquire into the career of successful men in the inventor's profession you will find, as a rule, that they are as remarkable for their physical as for their mental performance. I know that when I worked with Edison, after all of his assistants had been exhausted, he said to me: "I never saw such a thing, you take the cake." That was a characteristic way for him to express what I did. We worked from half past ten in the morning until five o'clock the next morning. I carried this on for nine months without a single day's exception; everybody else gave up. Edison stuck, but he occasionally dozed off on

the table. What I wish to say particularly is that my early life was really extraordinary in certain experiences which led to everything I ever did afterwards. It is important that this should be explained to you as otherwise you would not know how I discovered the rotating field. From childhood I was afflicted in a singular way - I would see images of objects and scenes with a strong display of light and of much greater vividness than those I had observed before. They were always images of objects and scenes I had actually seen, never of such as I imagined. I have asked students of psychology, physiology and other experts about it, but none of them has been able to explain the phenomena which seems to have been unique, although I was probably predisposed, because my brother also saw images in the same way. My theory is that they were simply reflex actions from the brain on the retina, super-induced by hyper-excitation of the nerves. You might think that I had hallucinations. That is impossible. They are produced only in diseased and anguished brains. My head was always clear as a bell, and I had no fear. Do you want me to tell of my recollections bearing on this? (Turning to the gentlemen on the platform). This is traditional with me, for I was too young to remember anything of what I said. I had two old aunts, I recall, with wrinkled faces, one of them with two great protruding teeth which she used to bury into my cheek when she kissed me. One day they asked me which of the two was prettier. After looking them over I answered: "This one is not as ugly as the other one." That was evidence of good sense. Now as I told you, I had no fear. They used to ask me, "Are you afraid of robbers?" and I would reply "No". "Of wolves?" "No". Then they would ask, "Are you afraid of crazy Luka?" (A fellow who would tear through the village and nothing could stop him) "No, I am not afraid of Luka." "Are you afraid of the gander?" "Yes, I am," I would reply and cling to my mother. That was because once they put me in the court yard with nothing on, and that beast ran up and grabbed me by the soft part of the stomach tearing off a piece of flesh. I still have the mark.

These images I saw caused me considerable discomfort. I will give you and illustration: Suppose I had witnessed a funeral. In my country the rites are but intensified torture. They smother the dead body with kisses, then they bathe it, expose it for three days, and finally one hears the dull thuds of the earth, when all is over. Some of the pictures as that of the coffin, for instance, would not appear vividly but were sometimes so persistent that when I would stretch my hand out I would see it penetrate the image. As I look at it now these images were simply reflex actions through the optic nerve on the retina, producing on the same an effect identical to that of a projection through the lens, and if my view is correct, then it will be possible, (and certainly my experience has demonstrated that), to project the image of any object one conceives in thought on a screen and make it visible. If this could be done it would revolutionize all human relations. I am convinced that it can and will be accomplished.

In order to free myself of these tormenting appearances, I tried to fix my mind on some other picture or image which I had seen, and in this way I would manage to get some relief; but in order to get this relief I had to let the images come one after the other very fast. Then I found that I soon exhausted all I had at my command, my "reel" was out, as it were. I had seen little of the world, only objects around my own home, and they took me a few times to some neighbors, that was all I knew. When I did so the second or third time, in order to chase the appearance from my vision, I found that this remedy lost all the force. Then I began to make excursions beyond the limits of the little world I knew, and I saw new scenes. These were at first very blurred and indistinct, and would flit away when I tried to concentrate my attention upon them, but by and by I succeeded in fixing them; they gained in force and distinctness and finally assumed the intensity of real things. Soon I observed that my best comfort was attained if I simply went on in my vision farther and farther, getting new impressions all the time, and so I started to travel - of course, in my mind. You know that there have been great

discoveries made - when Columbus found America that was one, but when I hit upon the idea of traveling it seemed to me that was the greatest discovery possible to man. Every night (and sometimes during the day), as soon as I was alone I would start on my travels. I would see new places, cities and countries, I would live there, meet people and make friendships and acquaintances, and these were just as dear to me as those in real life and not a bit less intense. That is the way I did until I reached almost manhood. When I turned my thoughts to invention, I found that I could visualize my conceptions with the greatest facility. I did not need any models, drawings or experiments, I could do it all in my mind, and I did. In this way I have unconsciously evolved what I consider a new method of materializing inventive concepts and ideas, which is exactly opposite to the purely experimental of which undoubtedly Edison is the greatest and most successful exponent. The moment you construct a device to carry into practice a crude idea you will find yourself inevitably engrossed with the details and defects of the apparatus. As you go on improving and reconstructing, your force of concentration diminishes and you lose sight of the great underlying principle. You obtain results, but at the sacrifice of quality. My method is different, I do not rush into constructive work. When I get an idea, I start right away to build it up in my mind. I change the structure, I make improvements, I experiment, I run the device in my mind. It is absolutely the same to me whether I operate my turbine in thought or test it actually in my shop. It makes no difference, the results are the same. In this way, you see, I can rapidly develop and perfect an invention, without touching anything. When I have gone so far that I have put into the device every possible improvement I can think of, that I can see no fault anywhere, I then construct this final product of my brain. Every time my device works as I conceive it should and my experiment comes out exactly as I plan it. In twenty years there has not been a single solitary experiment which did not turn out precisely as I thought it would. Why should it not? Engineering, electrical and mechanical, is positive in results. Almost any subject presented can be mathematically treated and the effects calculated; but if it is such that results cannot be had by simple methods of mathematics or short cuts, there is all the experience, and all the data on which to draw and from which to build; - why, then, should one carry out the crude idea? It is not necessary, it is a waste of energy, money and time. Now, that is just the way I produced the rotating field.

If I am to give you in a few words the history of that invention, I must begin with my birthday, and you will see the reason why. I was born exactly at midnight, I have no birthday and I never celebrate it. But something else must have happened on that date. I have learned that my heart beat on the right side and did so for many years after. As I grew up it beat on both sides, and finally settled on the left. I remember that I was surprised, when I developed into a very strong man, to find my heart on the left side. Nobody understands how it happened. I had two or three falls and on one occasion nearly all my chest bones were crushed in. Something that was quite unusual must have occurred at my birth and my parents destined me for the clergy then and there. When I was six years old I managed to have myself imprisoned in a little chapel at an inaccessible mountain, and visited only once a year. It was a place of many bloody encounters and there was a grave yard near by. I was locked in there while looking for some sparrows' nests, and had the most dreadful night I ever passed in my life, in company with the ghosts of the dead. American boys will not understand it, of course, for there are no ghosts in America - the people are too sensible; but my country was full of them, and every one from the small boy to greatest hero, who was plastered all over with medals for courage and bravery, had a fear of ghosts. Finally, as by a wonder, they rescued me, and then my parents said: "Surely he must go to the clergy, he must become a churchman." Whatever happened after that, no matter what it was, simply fortified them in that resolution. One day, to tell you a little story, I fell from the top of one of the farm buildings into a large kettle of milk, which was boiling over a

roaring fire. Did I say boiling milk? - It was not boiling - not according to the thermometer - though I would have sworn it was when I fell into it, and they pulled me out. But I only got a blister on the knee where I struck the hot kettle. My parents said again: "Was not that wonderful? Did you ever hear of such a thing? He will surely be a bishop, a metropolitan, perhaps a patriarch." In my eighteenth year I came to the cross roads. I had passed through the preliminary schools and had to make up my mind either to embrace the clergy or to run away. I had a profound respect for my parents, and so I resigned myself to take up studies for the clergy. Just then one thing occurred, and if it had not been for that, I would not have had my name connected with the occasion of this evening. A tremendous epidemic of cholera broke out, which decimated the population and, of course, I got immediately. Later it developed into dropsy, pulmonary trouble, and all sorts of diseases until finally my coffin was ordered. In one of the fainting spells when they thought I was dying, my father came to my bedside and cheered me: "You are going to get well." "Perhaps," I replied, "if you will let me study engineering." "Certainly I will," he assured me, "you will go to the best polytechnic school in Europe." I recovered to the amazement of everybody. My father kept his word, and after a year of roaming through the mountains and getting myself in good physical shape, I went to the Polytechnic School at Gratz, Styria, one of the oldest institutions. Something else occurred, however, of which I must tell you as it is vitally linked with this discovery. In the preparatory schools there was no liberty in the choice of subjects, and unless a student was proficient in all of them he could not pass. I found myself in this predicament every year. I could not draw. My faculty for imagining things paralyzed whatever gift I might have had in this respect. I have made some mechanical drawings, of course; practicing so many years one must needs learn to make simple sketches, but if I draw for half an hour I am all exhausted. I never was qualified and passed only through my father's influence. Now, when I went to the polytechnic school I had free choice of subjects and proposed myself to show my parents what I could do. The first year at the polytechnic school was spent in this way - I got up at three o'clock in the morning and worked until eleven o'clock at night, for one whole year, with a single day's exception. Well, you know when a man with a reasonably healthy brain works that way he must accomplish something. Naturally, I did. I graduated nine times that year and some of the professors were not satisfied with giving me the highest distinction, because they said, that did not express their idea of what I did, and here is where I come to the rotating field. In addition to the regular graduating papers they gave me some certificates which I brought to my father believing that I had achieved a great triumph. He took the certificates and threw them into the waste basket, remarking contemptuously: "I know how these testimonials are obtained." That almost killed my ambition; but later, after my father had died, I was mortified to find a package of letters, from which I could see that there had been considerable correspondence going on between him and the professors who had written to the effect that unless he took me away from school I would kill myself with work. Then I understood why he had slighted my success, which I was told was greater than any previous one at that institution; in fact the best students had only graduated twice. My record in the first year had the result that the professors became very much interested in and attached to me, particularly three of them; Prof. Rogner who was teaching arithmetical subjects and geometry; Prof. Alle, one of the most brilliant and wonderful lecturers I have ever seen, who specialized in differential equations, about which he wrote quite a number of works in German, and Prof. Poeschl, who was my instructor in physics. These three men were simply in love with me and used to give me problems to solve. Prof. Poeschl was a curious man. I never saw such feet in my life. They were about that size. (Indicating) His hands were like paws, but when he performed experiments they were so convincing and the whole went off so beautifully that one never realized how they were done. It was all in the method. He did all with the precision of a clock work, and everything succeeded.

It was in the second year of my studies that we received a Gramme machine from Paris, having a horse-shoe form of laminated magnet, and a wound armature with a commutator. We connected it up and showed various effects of currents. During the time Prof. Poeschl was making demonstrations running the machine as a motor we had some trouble with the brushes. They sparked very badly, and I observed: "Why should not we operate without the brushes?" Prof. Poeschl declared that it could not be done, and in view of my success in the past year he did me the honor of delivering a lecture touching on the subject. He remarked: "Mr. Tesla may accomplish great things, but he certainly never will do this," and he reasoned that it would be equivalent to converting a steadily pulling force, like that of gravity, into a rotary effort, a sort of perpetual motion scheme, an impossible idea. But you know that instinct is something which transcends knowledge. We have, undoubtedly, certain finer fibers that enable us to perceive truths when logical deduction, or any other willful effort of the brain, is futile. We cannot reach beyond certain limits in our reasoning, but with instinct we can go to very great lengths. I was convinced that I was right and that it was possible. It was not a perpetual motion idea, it could be done, and I started to work at once.

I will not tire you with an extended account of this undertaking, but will only say that I began in the summer of 1877 and I proceeded as follows: I would picture first of all, a direct-current machine, run it and see how the currents changed in the armature. Then I would imagine an alternator and do the same thing. Next I would visualize systems comprising motors and generators, and so on. Whatever apparatus I imagined, I would put together and operate in my mind, and I continued this practice incessantly until 1882. In that year somehow or other, I began to feel that a revelation was near. I could not yet see just exactly how to do it, but I knew that I was approaching the solution. While on my vacation, in 1882, sure enough, the idea came to me and I will never forget the moment. I was walking with a friend of mine in the city park of Budapest reciting passages from Faust. It was nothing for me to read from memory the contents of an entire book, with every word between the covers, from the first to the last. My sister and brother, however, could do much better than myself. I would like to know whether any of you has that kind of memory. It is curious, entirely visual and retroactive. To be explicit - when I made my exams, I had always to read the books three or four days if not a week before, because in that time I could reconstruct the images and visualize them; but if I had an examination the next day after reading, images were not clear and the remembrance was not quite complete. As I say, I was reciting Goethe's poem, and just as the sun was setting I felt wonderfully elated, and the idea came to me like a flash. I saw the whole machinery clearly, the generator, the motor, the connections, I saw it work as if it had been real. With a stick I drew on the sand the diagrams which were shown in my paper before the American Institute of Electrical Engineers and illustrated in my patents, as clearly as possible, and from that time on I carried this image in my mind. Had I been a man possessed of the practical gifts of Edison, I would have gone right away to perform an experiment and push the invention along, but I did not have to do this. I could see pictures so vividly, and what I imagined was so real and palpable, that I did not need any experimenting, nor would it have been particularly interesting to me. I went on and improved the plan continuously, inventing new types, and the day I came to America, practically every form, every kind of construction, every arrangement of apparatus I described in my thirty or forty patents was perfected, except just two or three kinds of motors which were the result of later development.

In 1883, I made some tests in Strasburg, as Mr. Terry pointed out, and there at the railroad station obtained the first rotation. The same experiment was repeated twice.

Now I come to an interesting chapter of my life, when I arrived in America. I had made some improvements in dynamos for a French company who were getting their

machinery from here. The improved forms were so much better that the manager of the works said to me: "You must go to America, and design the machines for the Edison Company." So, after ineffectual efforts on the other side to get somebody to interest himself in my plans financially, I came to this country. I wish that I could only give you an idea how what I saw here impressed me. You would be very much astonished. You have all undoubtedly read those charming Arabian Nights tales, in which the genie transports people into wonderful regions, to go through all sorts of delightful adventures. My case was just the opposite. The genie transported me from a world of dreams into one of realities. My world was beautiful, ethereal, as I could imagine it. The one I found here was a machine world; the contact was rough, but I liked it. I realized from the very moment I saw Castle Garden that I was a good American before I landed. Then came another event. I met Edison, and the effect he produced upon me was extraordinary. When I saw this wonderful man, who had had no theoretical training at all, no advantages, who did all himself, getting great results by virtue of his industry and application, I felt mortified that I had squandered my life. I had studied a dozen languages, delved in literature and art and had spent my best years in ruminating through libraries and reading all sorts of stuff that fell into my hands. I thought to myself, what a terrible thing it was to have wasted my life in those useless efforts. If I had only come to America earlier and devoted all of my brain power to inventive work, what might I have done? In later life though, I realized I would not have produced anything without the scientific training I got, and it is a question whether my surmise as to my possible accomplishment was correct. In Edison's works I passed nearly a year of the most strenuous labor, and then certain capitalists approached me with the project to form my own company. I went into the proposition, and developed the arc light. To show you how prejudiced people were against the alternating-current, as the President has indicated, when I told these friends of mine that I had a great invention relating to alternating-current transmission, they said: "No, we want the arc lamp. We do not care for this alternating-current." Finally I perfected my lighting system and the city adopted it. Then I succeeded in organizing another company, in April, 1886, and a laboratory was put up, where I rapidly developed these motors, and eventually the Westinghouse people approached us, and an arrangement was made for their introduction. You know what has happened since then. The invention has swept the world.

I should like to say just a few words regarding the Niagara Falls enterprise. We have a man here to-night to whom belongs really the credit for the early steps and for the first financiering of the project, which was difficult at that time. I refer to Mr. E. D. Adams. When I heard that such authorities as Lord Kelvin and Prof. W. C. Unwin had recommended - one the direct-current system and the other compressed air - for the transmission of power from Niagara Falls to Buffalo, I thought it was dangerous to let the matter go further, and I went to see Mr. Adams. I remember the interview perfectly. Mr. Adams was much impressed with what I told him. We had some correspondence afterwards, and whether it was in consequence of my enlightening him on the situation, or owing to some other influence, my system was adopted. Since that time, of course, new men, new interests have come in, and what has been done I do not know, except that the Niagara Falls enterprise was the real starting impulse in the great movement inaugurated for the transmission and transformation of energy on a huge scale.

Mr. Terry has referred to other inventions of mine. I will just make a few remarks relative to these as some of my work has been misunderstood. It seems to me that I ought to tell you a few words about an effort that absorbed my attention later. In 1892 I delivered a lecture at the Royal Institution and Lord Rayleigh surprised me by acknowledging my work in very generous terms, something that is not customary, and among other things he stated that I had really an extraordinary gift for invention. Up to that time, I can assure you, I had hardly realized that I was

an inventor. I remembered, for instance, when I was a boy, I could go out into the forest and catch as many crows as I wanted, and nobody else could do it. Once, when I was seven years of age, I repaired a fire engine which the engineers could not make work, and they carried me in triumph through the city. I constructed turbines, clocks and such devices as no other boy in the community. I said to myself: "If I really have a gift for invention, I will bend it to some great purpose or task and not squander my efforts on small things." Then I began to ponder just what was the greatest deed to accomplish. One day as I was walking in the forest a storm gathered and I ran under a tree for shelter. The air was very heavy, and all at once there was a lightning flash, and immediately after a torrent of rain fell. That gave me the first idea. I realized that the sun was lifting the water vapor, and wind swept it over the regions where it accumulated and reached a condition when it was easily condensed and fell to earth again. This life-sustaining stream of water was entirely maintained by sun power, and lightning, or some other agency of this kind, simply came in a trigger-mechanism to release the energy at the proper moment. I started out and attacked the problem of constructing a machine which would enable us to precipitate this water whenever and wherever desired. If this was possible, then we could draw unlimited amounts of water from the ocean, create lakes, rivers and water falls, and indefinitely increase the hydroelectric power, of which there is now a limited supply. That led me to the production of very intense electrical effects. At the same time my wireless work, which I had already begun, was exactly in that direction, and I devoted myself to the perfection of that device, and in 1908, I filed an application describing an apparatus with which I thought the wonder could be achieved. The Patent Office Examiner was from Missouri, he would not believe that it could be done, and my patent was never granted. But in Colorado I had constructed a transmitter by which I produced effects in some respects at least greater than those of lightning. I do not mean in potential. The highest potential I reached was something like 20,000,000 volts, which is insignificant as compared to that of lightning, but certain effects produced by my apparatus were greater than those of lightning. For instance, I obtained in my antennae currents of from 1,000 to 1,100 amperes. That was in 1899 and you know that in the biggest wireless plants of today only 250 amperes are used. In Colorado I succeeded one day in precipitating a dense fog. There was a mist outside, but when I turned on the current the cloud in the laboratory became so dense that when the hand was held only a few inches from the face it could not be seen. I am positive in my conviction that we can erect a plant of proper design in an arid region, work it according to certain observations and rules, and by its means draw from the ocean unlimited amounts of water for irrigation and power purposes. If I do not live to carry it out, somebody else will, but I feel sure that I am right.

As to the transmission of power through space, that is a project which I considered absolutely certain of success long since. Years ago I was in the position to transmit wireless power to any distance without limit other than that imposed by the physical dimensions of the globe. In my system it makes no difference what the distance is. The efficiency of the transmission can be as high as 96 or 97 per cent, and there are practically no losses except such as are inevitable in the running of the machinery. When there is no receiver there is no energy consumption anywhere. When the receiver is put on, it draws power. That is the exact opposite of the Hertz-wave system. In that case, if you have a plant of 1,000 horsepower, it is radiating all the time whether the energy is received or not; but in my system no power is lost. When there are no receivers the plant consumes only a few horsepower necessary to maintain the electric vibration; it runs idle, as the Edison plant when the lamps and motors are shut off.

I have made advances along this line in later years which will contribute to the practical features of the system. Recently I have obtained a patent on a transmitter with which it is practicable to transfer unlimited amount of energy to any distance.

I had a very interesting experience with Mr. Stone, whom I consider, if not the ablest, certainly one of the ablest living experts. I said to Mr. Stone: "Did you see my patent?" He replied: "Yes, I saw it, but I thought you were crazy." When I explained it to Mr. Stone he said, "Now, I see; why, that is great," and he understood how the energy is transmitted.

To conclude, gentlemen, we are coming to great results, but we must be prepared for a condition of paralysis for quite a while. We are facing a crisis such as the world has never seen before, and until the situation clears the best thing we can do is to devise some scheme for overcoming the submarines, and that is what I am doing now. (Applause)

ALFRED H. COWLES: Here are some pictures you gave to me twenty years ago, relating to your experiments of 1899, I think you will be interested in seeing them. (Hands pictures to Mr. Tesla)

NIKOLA TESLA: I have learned how to put up a plant that will develop a tension of 100,000,000 volts and handle it with perfect safety. This plant (indicating) was in Colorado. If anybody, who had not been dabbling in these experiments as long as myself, had done such work, he would surely have been killed. In this plant I had the narrowest escape ever. It was a square building, in which there was a coil 52 feet in diameter, about nine feet high. When it was adjusted to resonance, the streamers passed from top to bottom and it was a most beautiful sight. You see, that was about fifteen hundred, perhaps two thousand square feet of streamer surface. To save money I had calculated the dimensions as closely as possible, and the streamers came within six or seven inches from the sides of the building. As boys had been looking through a single window provided in the rear, I nailed it up. For handling the heavy currents, I had a special switch. It was hard to pull, and I had a spring arranged so that I could just touch the handle and it would snap in. I sent one of my assistants down town and was experimenting alone. I threw up the switch and went behind the coil to examine something. While I was there the switch snapped in, when suddenly the whole room was filled with streamers, and I had no way of getting out. I tried to break through the window but in vain as I had no tools, and there was nothing else to do than to throw myself on my stomach and pass under. The primary carried 500,000 volts, and I had to crawl through the narrow place here (pointing) with the streamers going. The nitrous acid was so strong I could hardly breathe. These streamers rapidly oxidize nitrogen because of their enormous surface, which makes up for what they lack in intensity. When I came to the narrow space they closed on my back. I got away and barely managed to open the switch when the building began to burn. I grabbed a fire extinguisher and succeeded in smothering the fire. Then I had enough, I was all in. But now I can operate a plant without any fear of its destruction by fire. Mr. Cowles is responsible for excursion into this matter. (Applause)

THE PRESIDENT: If there is no further business, we will consider this meeting adjourned.

Feb. 7, 1918

A LIGHTING MACHINE ON NOVEL PRINCIPLES - by Nikola Tesla

A machine built on novel and original lines is about to be placed on the market. It consists of a turbine and electric generator, both employing basically new principles in construction as well as operation, and intimately associated to constitute a unit. The former has been pronounced revolutionary in its design and performance. It is simplicity itself, being devoid of buckets, deflecting blades, guide passages, vanes and the like, and presents many other decisive advantages over the ordinary prime mover.

In the first place there is no windage, which is the cause of a most serious loss of power in bucket turbines, often amounting to a large percentage of the integral mechanical effort. What is still more important, the new turbine is capable of taking up the whole velocity of the motive fluid in one continuous process, thus saving the expense and avoiding the complication incident to "staging". Furthermore, it has the precious quality of transforming into useful work frictional energy irretrievably spent in other heat motors.

The corrosion and erosion of buckets and vanes in the present turbines is the cause of another great and irremediable waste of energy, the water rate frequently increasing 30% to 40% after but a few months of use. No such hurtful actions exist in the new turbine, and if they did, they would not impair the performance to any appreciable degree. Again, the former are subject to considerable loss owing to unpreventable wear and deterioration of the nozzles. It is essential that the high velocity streams of fluid issuing from them be directed upon the curved blades with great precision, as a failure of this is fatal to good results. To such an extent is this the case that even a slight roughening of the polished surfaces will reduce the useful energy as much as 25%. The new turbine is entirely free from this defect. However the nozzle may be used up, the fluid is made to flow through the wheel smoothly and evenly in natural stream lines, transmitting power to the same with undiminished efficiency. Another feature of superiority is found in its adaptability to high temperatures far beyond those practicable in bucket turbines. For every hundred degrees of increase in temperature, the steam consumption is reduced from 10% to 12%. Great economies are thus made possible by the use of the new prime mover.

In every turbine the device regulating the speed of rotation and controlling the admission of the working fluid to the nozzles is of vital importance. With scarcely an exception it is of the centrifugal type driven from the shaft in some or other way and constituting an assemblage of gears, flying weights, links, levers, sleeves, thrust bearings and other parts. It is an apparatus complex and delicate, expensive to construct and easily deranged, often with disastrous consequences. All this has been done away in the new turbine which is controlled in a novel and striking manner. The regulator is elementary in its construction, positive and unfailing in its action, and yet so sensitive as to respond to variations of load amounting to less than 1% of the normal. This simple device is rendered still more valuable by the fact that it adjusts itself instantaneously to pressure changes so that the effects of these on the lamps are inappreciable. To illustrate, the steam gauge on the boiler may indicate fluctuations from 100 to 200 pounds or more and following each other however rapidly without the slightest observable change in the intensity of the light. This remarkable action of the device is independent of its function as regulator of speed.

Another advantage deserving the most careful consideration of the user is the perfect safety of the new turbine. There is an ever present danger in a machine of the old type, that the wheel might burst and destroy life and property. Such a deplorable accident is absolutely impossible with the new turbine rotor, composed of thin

discs which expand slightly and come to rest, invariably without damage, as has been shown in exhaustive experiments.

The one feature, however, which has most amazed experts, is the extraordinary power of this form of prime mover. Owing to the great effectiveness of the underlying principle and peculiar construction, ten times more power can be produced than with any other machine known. For example, a rotor of 9" in diameter, weighing less than 20 pounds, can readily develop 200 brake horsepower, and this is by no means the limit of performance.

But the merits of this lighting outfit do not rest on the turbine alone. The dynamo associated with the same is perhaps equally noteworthy by its simplicity of construction, high efficiency and rare and valuable properties it possesses. It consists of a smooth cylindrical body mounted on the turbine shaft and arranged to rotate within a magnetic field of novel form. There is no brush or sliding contact whatever, the current being taken from stationary terminals to which the ends of the generating coils are connected. By employing the best materials and workmanship and resorting to artifices of design, a most economical electrical generator is produced, the efficiency being over 90% even in machines of very small size having rotors of not more than 2½" in diameter. This generator possesses extraordinary qualities, especially desirable in electric lighting. It is capable of furnishing a current constant within a minute fraction of 1% through a very wide range of speed variation, and as such is ideally suited for running arc lamps or kindred electrical devices in series. More surprising still and also of greater commercial import is its capability of maintaining a constant potential. Such results as are obtainable with it are wholly impossible with other types of electrical generators. It has been found in practice that all lamps but one can be turned off suddenly without the slightest perceptible flicker and even without any observable effect on the needle of a delicate instrument indicating the voltage.

That an apparatus of such simplicity and presenting so many salient advantages should find an extensive use in electric lighting might be naturally expected, but its overwhelming superiority will be better appreciated when it is stated that it occupies hardly more than one-tenth of the space of apparatus of the usual forms and weighs less in proportion. A machine capable of developing 1-kilowatt, for instance, goes into a space of 8 x 8 x 10" and weighs but 40 pounds. It takes not more than one-third of the steam consumed in other turbo-generators of that size.

The guiding idea in the development of this new machine was to evolve a mechanism approximating a static transformer of energy in simplicity, efficiency and reliability of operation. Every detail has been worked out with this object in view. There is no exciter, no commutator, brush or sliding contact whatever, no centrifugal regulator, voltage controller or any such complicated and hazardous device. The machine consists of but a stationary solid frame and two smooth cylindrical steel bodies mounted on a strong shaft arranged to rotate in bearings virtually frictionless. No oiling is required, although a small quantity of lubricant is provided rather as a precaution than necessity. A perfect dynamic balance is secured in a novel manner and insures a steady and quiet running without tremor and vibration. The whole apparatus can be boxed up and depended upon to operate uninterruptedly through long periods of time. The outfit can be constructed in various sizes up to 100-kilowatt or more, and should meet more satisfactorily than any yet devised the varied requirements of electric lighting on railroads, boats, in public buildings, factories and mines, and may also be advantageously utilized in connection with existing plants for replacing belt driven dynamos and storage batteries, and relieving larger engines through the night and hours of small load.

(This material previously unpublished - Ed.)

Famous Scientific Illusions

By NIKOLA TESLA

Written specially for the Electrical Experimenter

In this original and revolutionizing discussion, Nikola Tesla gives us something really new to think about. First—Does the moon rotate on its axis? Second—Is the Franklin pointed lightning rod correct in theory and operation? Third—Do wireless signals fly thru space by means of so-called Hertzian waves in the ether, or are they propagated thru the earth at prodigious velocity by means of earth-bound oscillations? World-famous conundrums these—questions which have been answered in many ways by some of the greatest scientists. Dr. Tesla explains these three predominant scientific fallacies in a masterly way, so that everyone can understand them.

THE human brain, with all its wonderful capabilities and power, is far from being a faultless apparatus. Most of its parts may be in perfect working order, but some are atrophied, undeveloped or missing altogether. Great men of all classes and pro-

electric current according to a childish simple rule. The writer, who was known to recite entire volumes by heart, has never been able to retain in memory and recapitulate in their proper order the words designating the colors of the rainbow, and can only ascertain them after long and la-

reality. The greatest triumphs of man were those in which his mind had to free itself from the influence of delusive appearances. Such was the revelation of Buddha that self is an illusion caused by the persistence and continuity of mental images; the discovery of Copernicus that,

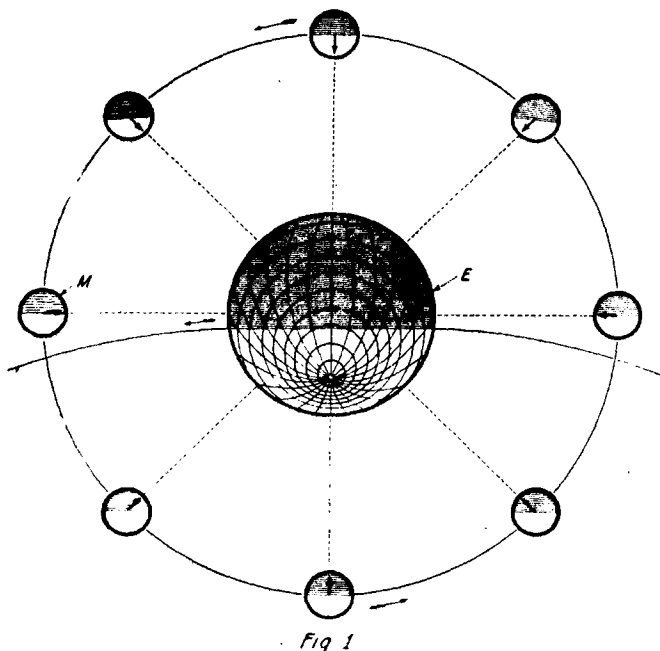

Fig 1

It is Well Known That the Moon, M., Always Turns the Same Face Toward the Earth, E, as the Black Arrows Indicate. The Parallel Rays From the Sun Illuminate the Moon in its Successive Orbital Positions as the Unshaded Semi-circles Indicate. Bearing This in Mind, Do You Believe That the Moon Rotates on its Own Axis?

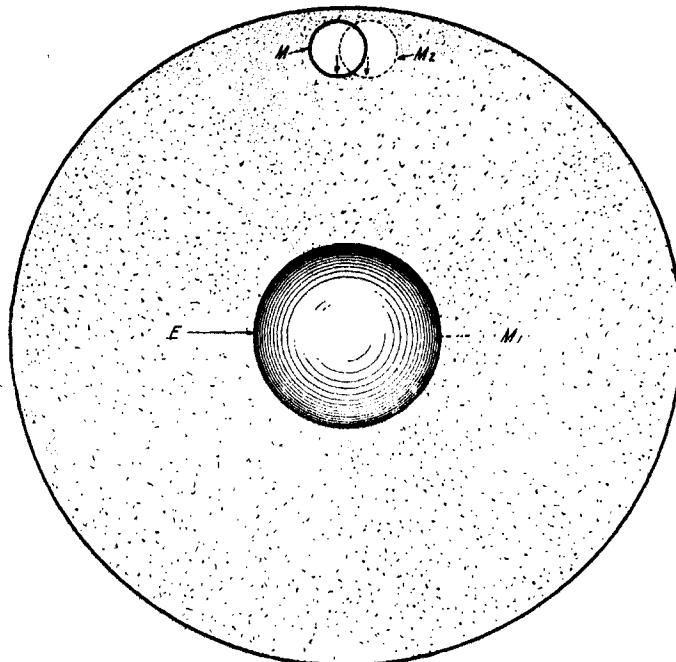

Fig. 2.—Tesla's Conception of the Rotation of the Moon, M, Around the Earth, E; the Moon, in This Demonstration Hypothesis, Being Considered as Embedded in a Solid Mass, M₁. If, As Commonly Believed, the Moon Rotates, This Would Be Equally True For a Portion of the Mass M₂, and the Part Common to Both Bodies Would Turn Simultaneously in "Opposite" Directions.

fessions—scientists, inventors, and hard-headed financiers—have placed themselves on record with impossible theories, inoperative devices, and unrealizable schemes. It is doubtful that there could be found a single work of any one individual free of error. There is no such thing as an infallible brain. Invariably, some cells or fibers are wanting or unresponsive, with the result of impairing judgment, sense of proportion, or some other faculty. A man of genius eminently practical, whose name is a household word, has wasted the best years of his life in a visionary undertaking. A celebrated physicist was incapable of tracing the direction of an

borious thought, strange as it may seem.

Our organs of reception, too, are deficient and deceptive. As a semblance of life is produced by a rapid succession of inanimate pictures, so many of our perceptions are but trickery of the senses, devoid of

contrary to all observation, this planet rotates around the sun; the recognition of Descartes that the human being is an automaton, governed by external influence and the idea that the earth is spherical, which led Columbus to the finding of this

continent. And tho the minds of individuals supplement one another and science and experience are continually eliminating fallacies and misconceptions, much of our present knowledge is still incomplete and unreliable. We have sophisms in mathematics which cannot be disproved. Even in pure reasoning, free of the shortcomings of symbolic processes, we are often arrested by doubt which the strong-

FOR over a century and a half the whole world, educated and otherwise, thought that the moon revolved around its axis. Nikola Tesla in the present highly instructive article disproves that theory and will convince scientists and all others alike that the moon does no such thing.

For thousands of years it was thought that the sun and stars revolved around the earth and all kinds of experimental proofs were furnished to substantiate this theory. The illustrious Galileo thought different, and everyone today knows that the earth revolves around the sun. So it is with Tesla's discovery. Tesla also, in the second part of the present paper, shows us that the ancient and time-worn theory advanced by Benjamin Franklin as to the lightning conductor is not substantially correct as viewed by latter day science. It will come as a shock even to our professors that the lightning rod actually aids the lightning in hitting the building. The reason is that the lightning rod helps in ionizing (making conductive) the surrounding air.

Mr. Tesla has devised a lightning conductor with no points, and there is no doubt whatsoever that his theory is right. Scientists the world over will acknowledge this very shortly.

In a third section of the same paper Tesla explodes still another popular delusion, viz., that wireless waves follow the curvature of the earth when messages are transmitted, let us say from a point in the United States to a point in Europe. In his revolutionary arguments, supported by facts as well as by logic, Tesla shows why the currents do not travel around the earth but directly thru it. In other words, Tesla maintains that wireless communication is accomplished ONLY thru the medium of the earth itself. His contention seems very sound. If it were not so, let every wireless station, commercial or otherwise, do away with its ground connection. None could then operate as is well known except perhaps over very limited distances.

Mr. Tesla's present article will arouse world-wide comment due to the revolutionary philosophy contained therein. We are sure our readers will appreciate Mr. Tesla's most timely and illuminating article on this but little understood subject.

est intelligences have been unable to dispel. Experimental science itself, most positive of all, is not unfaithful.

In the following I shall consider three exceptionally interesting errors in the interpretation and application of physical phenomena which have for years dominated the minds of experts and men of science.

I. The Illusion of the Axial Rotation of the Moon.

It is well known since the discovery of Galileo that the moon, in travelling thru space, always turns the same face towards the earth. This is explained by stating that while passing once around its mother-planet the lunar globe performs just one revolution on its axis. The spinning motion of a heavenly body must necessarily undergo modifications in the course of time, being either retarded by resistances internal or external, or accelerated owing to shrinkage and other causes. An unalterable rotational velocity thru all phases of planetary evolution is manifestly impossible. What wonder, then, that at this very instant of its long existence our satellite should revolve exactly so, and not faster or slower. But many astronomers have accepted as a physical fact that such rotation takes place. It does not, but only appears so; it is an illusion, a most surprising one, too.

I will endeavor to make this clear by reference to Fig. 1, in which E represents the earth and M the moon. The movement thru space is such that the arrow, firmly attached to the latter, always occupies the position indicated with reference to the earth. If one imagines himself as looking down on the orbital plane and follows the motion he will become convinced that the moon *does* turn on its axis as it travels around. But in this very act the observer will have deceived himself. To make the delusion complete let him take a washer similarly marked and supporting it rotatably in the center, carry it around a stationary object, constantly keeping the arrow pointing towards the latter. Tho to his bodily

vision the disk will revolve on its axis, such movement does not exist. He can dispel the illusion at once by holding the washer fixedly while going around. He will now readily see that the supposed axial rotation is only apparent, the impression being produced by successive changes of position in space.

But more convincing proofs can be given that the moon does not, and cannot revolve on its axis. With this object in view attention is called to Fig. 2, in which both the satellite, M, and earth, E, are shown embedded in a solid mass, M₁ (indicated by stippling) and supposed to rotate so as to impart to the moon its normal translatory velocity. Evidently, if the lunar globe could rotate as commonly believed, this would be equally true of any other portion of mass M₁, as the sphere M₂, shown in dotted lines, and then the part common to both bodies would have to turn *simultaneously in opposite directions*. This can be experimentally illustrated in the manner suggested by using instead of one, two overlapping rotatable washers, as may be conveniently represented by circles M and M₂, and carrying them around a center as E, so that the plain and dotted arrows are always pointing towards the same center. No further argument is needed to demonstrate that the two gyrations cannot co-exist or even be pictured in the imagination and reconciled in a purely abstract sense.

The truth is, the so-called "axial rotation" of the moon is a phenomenon deceptive alike to the eye and mind and devoid of physical meaning. It has nothing in common with real mass revolution characterized by effects positive and unmistakable. Volumes have been written on the subject and many erroneous arguments advanced in support of the notion. Thus, it is reasoned, that if the planet did *not* turn on its axis it would expose the whole surface to terrestrial view; as only one-half is visible, it *must* revolve. The first statement is true but the logic of the second is defective, for it admits of only one alternative. The conclusion is not justified as the same appearance can also be produced in another way. The moon does rotate, not on its own, but about an axis passing thru the center of the earth, the true and only one.

The unfaithful test of the spinning of a mass is, however, the existence of

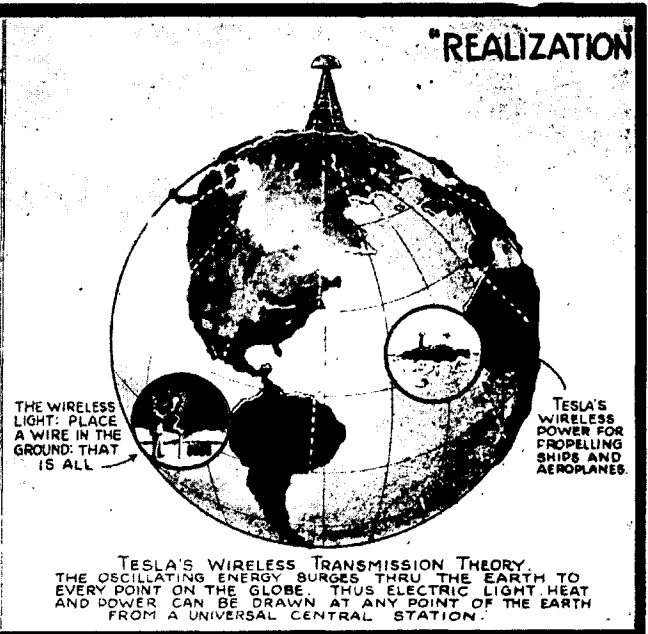
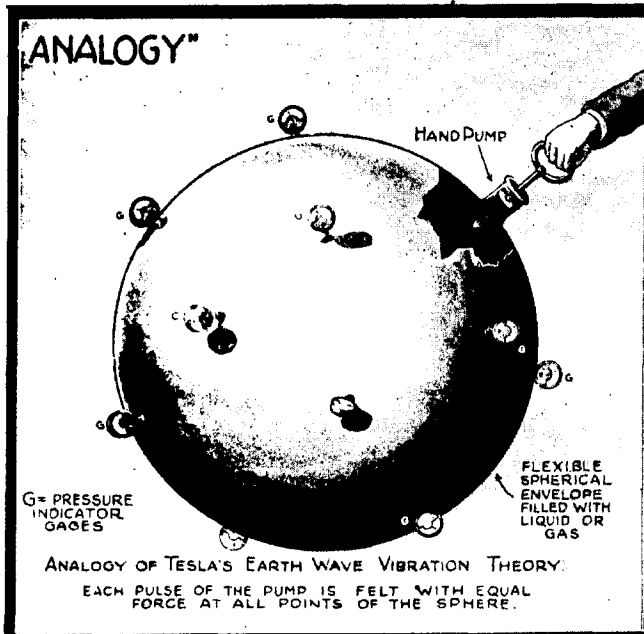
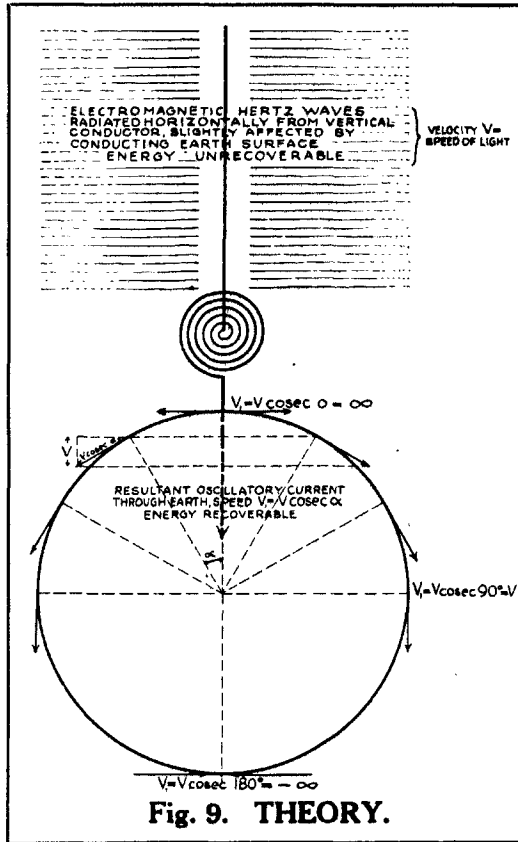

Tesla's World-Wide Wireless Transmission of Electrical Signals, As Well As Light and Power, is Here Illustrated in Theory, Analogy and Realization. Tesla's Experiments With 100 Foot Discharges At Potentials of Millions of Volts Have Demonstrated That the Hertz Waves Are Infinitesimal In Effect and Unrecoverable; the Recoverable Ground Waves of Tesla Fly "Thru the Earth". Radio Engineers Are Gradually Beginning to See the Light and That the Laws of Propagation Laid Down by Tesla Over a Quarter of a Century Ago Form the Real and True Basis of All Wireless Transmission To-Day.

energy of motion. The moon is not posses of such *vis viva*. If it were the case then a revolving body as M_1 would contain mechanical energy other than that of which

tion of the latter immediately stiffens, being at the same time deformed by gravitational pull. The shape becomes permanent upon cooling and solidification and the smaller

show any measurable flattening in form.

2. If a planetary body in its orbital movement turns the same side towards the central mass this is a positive proof that it has been separated from the latter and is a true satellite.

3. A planet revolving on its axis in its passage around another cannot have been thrown off from the same but must have been captured.

II. The Fallacy of Franklin's Pointed Lightning-Rod.

The display of atmospheric electricity has since ages been one of the most marvelous spectacles afforded to the sight of man. Its grandeur and power filled him with fear and superstition. For centuries he attributed lightning to agents god-like and supernatural and its purpose in the scheme of this universe remained unknown to him. Now we have learned that the waters of the ocean are raised by the sun and maintained in the atmosphere delicately suspended, that they are wafted to distant regions of the globe where electric forces assert themselves in upsetting the sensitive balance and causing precipitation, thus sustaining all organic life. There is every reason to hope that man will soon be able to control this life-giving flow of water and thereby solve many pressing problems of his existence.

Atmospheric electricity became of special scientific interest in Franklin's time. Faraday had not yet announced his epochal discoveries in magnetic induction but static frictional machines were already generally used in physical laboratories. Franklin's powerful mind at once leaped to the conclusion that frictional and atmospheric electricity were identical. To our present view this inference appears obvious, but in his time the mere thought of it was little short of blasphemy. He investigated the phenomena and argued that if they were of the same nature then the clouds could be drained of their charge exactly as the ball of a static machine, and in 1749 he indicated in a published memoir how this could be done by the use of pointed metal rods.

(Continued on page 728)

Fig. 5
Highly rarefied medium (insulating).--

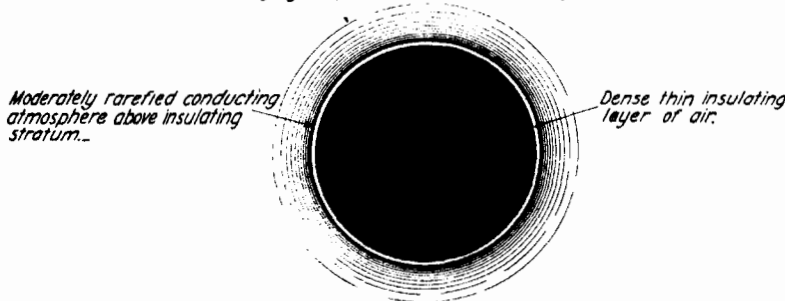
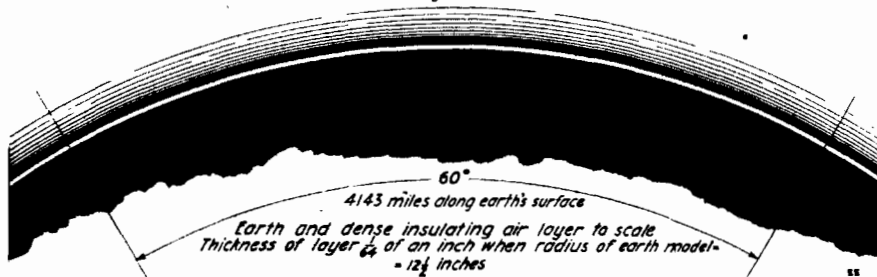

Fig. 6



A Section of the Earth and Its Atmospheric Envelope Drawn to Scale. It is Obvious That the Hertzian Rays Cannot Traverse So Thin a Crack Between Two Conducting Surfaces For Any Considerable Distance, Without Being Absorbed, Says Dr. Tesla, in Discussing the Ether Space Wave Theory.

we have experimental evidence. Irrespective of this so exact a coincidence between the axial and orbital periods is, in itself, immensely improbable for this is not the permanent condition towards which the system is tending. Any axial rotation of a mass left to itself, retarded by forces external or internal, must cease. Even admitting its perfect control by tides the coincidence would still be miraculous. But when we remember that most of the satellites exhibit this peculiarity, the probability becomes infinitesimal.

Three theories have been advanced for the origin of the moon. According to the oldest suggested by the great German philosopher Kant, and developed by Laplace in his monumental treatise "Mécanique Céleste", the planets have been thrown off from larger central masses by centrifugal force. Nearly forty years ago Prof. George H. Darwin in a masterful essay on tidal friction furnished mathematical proofs, deemed unrefutable, that the moon had separated from the earth. Recently this established theory has been attacked by Prof. T. J. J. See in a remarkable work on the "Evolution of the Stellar Systems", in which he propounds the view that centrifugal force was altogether inadequate to bring about the separation and that all planets, including the moon, have come from the depths of space and have been captured. Still a third hypothesis of unknown origin exists which has been examined and commented upon by Prof. W. H. Pickering in "Popular Astronomy of 1907", and according to which the moon was torn from the earth when the later was partially solidified, this accounting for the continents which might not have been formed otherwise.

Undoubtedly planets and satellites have originated in both ways and, in my opinion, it is not difficult to ascertain the character of their birth. The following conclusions can be safely drawn:

1. A heavenly body thrown off from a larger one cannot rotate on its axis. The mass, rendered fluid by the combined action of heat and pressure, upon the reduc-

mass continues to move about the larger one as tho it were rigidly connected to it except for pendular swings or librations due to varying orbital velocity. Such motion precludes the possibility of axial rotation in the strictly physical sense. The moon has never spun around as is well demonstrated by the fact that the most precise measurements have failed to

MODE OF PROPAGATION OF THE CURRENT FROM THE TRANSMITTER THRU THE EARTH

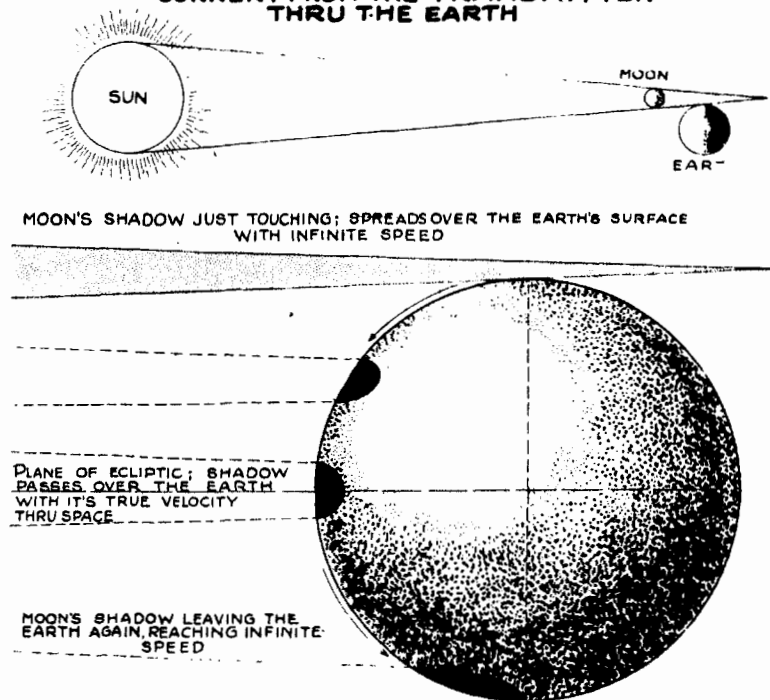

Fig. 8.—This Diagram Illustrates How, During a Solar Eclipse, the Moon's Shadow Passes Over the Earth With Changing Velocity, and Should Be Studied in Connection With Fig. 9. The Shadow Moves Downward With Infinite Velocity at First, Then With Its True Velocity Thru Space, and Finally With Infinite Velocity Again.

Famous Scientific Illusions

(Continued from page 694)

The earliest trials were made by Dalibrand in France, but Franklin himself was the first to obtain a spark by using a kite, in June, 1752. When these atmospheric discharges manifest themselves today in our wireless station we feel annoyed and wish that they would stop, but to the man who discovered them they brought tears of joy.

latter has the property of quickly dissipating the accumulated charge into the air. To examine this action in the light of present knowledge we may liken electric potentials to temperature. Imagine that sphere s is heated to T degrees and that the pin or metal bar is a perfect conductor of heat so that its extreme end is at the same tem-



BE A BOY CHEMIST

Test water, foods and other things you use and wear. Make soap, ink, dye; fire-proof cloth and wood, and work hundreds of useful, fascinating experiments just like a real chemist. Perform weird, puzzling tricks of chemical magic. You can, with "CHEMCRAFT." Outfits contain all chemicals and laboratory supplies to work each experiment many times; also a Manual of Instruction. "CHEMCRAFT" is absolutely harmless; made by a practical chemist and is scientifically correct.

Chemcraft No. 1—\$1.50
West of Mississippi River and in Canada—\$2.00
Chemcraft No. 2—\$3.00
West of Mississippi River and in Canada—\$3.50
Chemcraft No. 3—\$5.00
West of Mississippi River and in Canada—\$6.00

Be sure you get "CHEMCRAFT," the original and most complete and scientific chemical outfit. Ask for it by name at your toy store, or send price and we will deliver direct prepaid.

THE PORTER CHEMICAL CO.
Industrial Bldg., W. Washington St.
Hagerstown Maryland

BOYS Build and Fly Your Own Training Plane

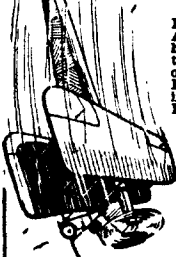

Train yourself in Aviation. Be an Amateur Aviator with an Aeroplane of your own. Learn how Aeroplanes are built; learn the principles of construction, operation and control. We sell IDEAL Accurate Scale Drawings, and Building and Flying Instructions which show you how to build a perfect Model Aeroplane, 8 ft. size, that will rise from the ground by its own power and fly like a big one. Send now for the Drawings and Instructions for the one you want to build.

Drawings and Instructions for
Curtiss Military Tractor **25c**
Bleriot Monoplane **EACH**
Nieuport Monoplane **EACH**
Tauble Monoplane **EACH**
Curtiss Flying Boat **Seven**
Wright Scheme **\$1.50**
Cocott Feed Saver **postpaid!**

Ideal Model Aeroplane Catalogue—None Free
Talk about Model Aeroplanes, Racing Aeroplanes, Flying Toys, and parts and supplies to build them with. 48 pages. Sent only upon receipt of 5 cents.
IDEAL AEROPLANE & SUPPLY COMPANY
79-82 West Broadway New York City

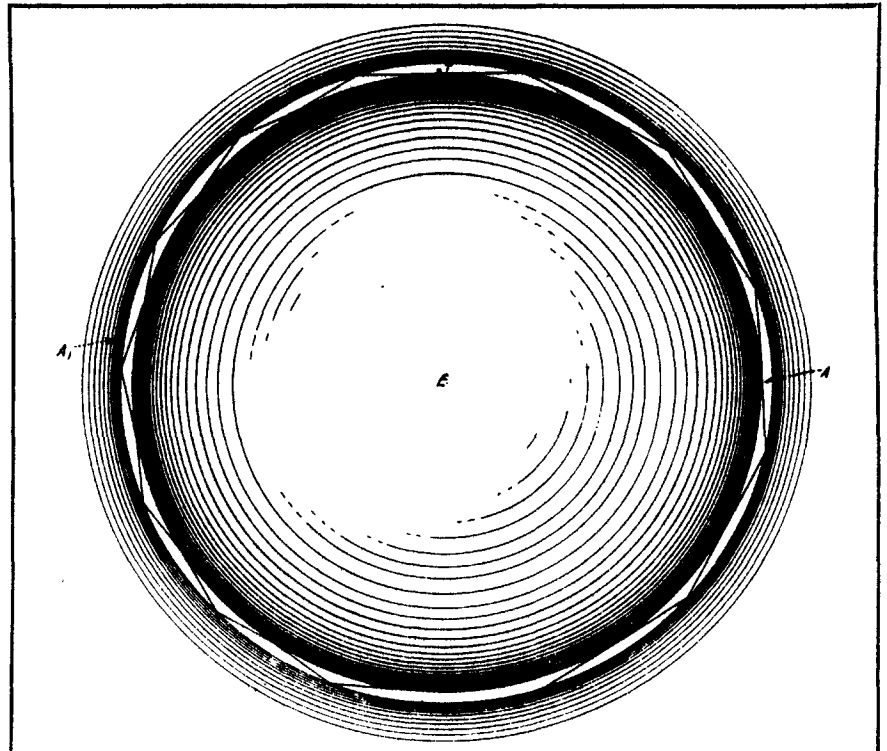

Fig. 7

The Theory Has Been Seriously Advanced and Taught that the Radio Ether Wave Oscillations Pass Around the Earth by Successive Reflections, as Here Shown. The Efficiency of Such a Reflector Cannot be more than 25 Per Cent; the Amount of Energy Recoverable in a 12,000-mile Transmission being but One Hundred and Fifteen Billionth Part of One Watt, with 1,000 Kilowatts at the Transmitter.

The lightning conductor in its classical form was invented by Benjamin Franklin in 1755 and immediately upon its adoption proved a success to a degree. As usual, however, its virtues were often exaggerated. So, for instance, it was seriously claimed that in the city of Pietermaritzburg (capital of Natal, South Africa) no lightning strokes occurred after the pointed rods were installed, altho the storms were as frequent as before. Experience has shown that just the opposite is true. A modern city like New York, presenting innumerable sharp points and projections in good contact with the earth, is struck much more often than equivalent area of land. Statistical records, carefully compiled and published from time to time, demonstrate that the danger from lightning to property and life has been reduced to a small percentage by Franklin's invention, but the damage by fire amounts, nevertheless, to several million dollars annually. It is astonishing that this device, which has been in universal use for more than one century and a half, should be found to involve a gross fallacy in design and construction which impairs its usefulness and may even render its employment hazardous under certain conditions.

For explanation of this curious fact I may first refer to Fig. 3, in which s is a metallic sphere of radius r , such as the capacity terminal of a static machine, provided with a sharply pointed pin of length h , as indicated. It is well known that the

temperature T . Then if another sphere of larger radius, v_1 , is drawn about the first and the temperature along this boundary is T_1 , it is evident that there will be between the end of the bar and its surrounding a difference of temperature $T - T_1$, which will determine the outflow of heat. Obviously, if the adjacent medium was not affected by the hot sphere this temperature difference would be greater and more heat would be given off. Exactly so in the electric system. Let q be the quantity of the charge, then the sphere—and owing to its great conductivity also the pin—will be at

the potential $\frac{q}{r}$. The medium around the point of the pin will be at the potential $\frac{q}{r_1}$ and, consequently, the difference $\frac{q}{r} - \frac{q}{r_1}$ and, consequently, the difference $\frac{q}{r} - \frac{q}{r+h}$ and, consequently, the difference $\frac{q}{r} - \frac{q}{r+h}$. Suppose now that a sphere S of much larger radius $R = nr$ is employed containing a charge Q this difference of potential will be, analogously $\frac{Q}{R} - \frac{Q}{R+h}$. According to elementary

principles of electro-statics the potentials of the two spheres s and S will be equal if $Q = nq$ in which case $\frac{Q}{R} - \frac{Q}{R+h} = \frac{q}{r} - \frac{q}{r+h}$

(Continued on page 730)



The Electric Safety razor makes shaving a pleasure. Blade vibrating 7,200 times a minute cuts the beard smoothly and without slightest pull or irritation—feels like a gentle massage. Can be used with or without electric current.

All users of the **Lek-Tro-Shav** speak well of it

A barber says—"Have shaved for years and have never used any shaving device near its equal."
A home user says—"The most pleasing shave I've ever had in my life. Shaves my face closer than I used to shave, but there is no after irritation or ill effects as I usually get from another razor."
No. 1. Made for use from Light Socket.
No. 2. Made for use from Dry Battery.

Write for illustrated circular describing Lek-Tro-Shav Safety Razor fully.

VIBRATING ELECTRIC RAZOR CO.
Dept. 122, Omaha, Nebr.

Printing Cheap
Cards, circulars, labels, book, paper. Presses, larger \$20 Job press \$50 up. Save money. Print for profit. No. 1. Made for use from Light Socket. No. 2. Made for use from Dry Battery. Write factory for press catalog, TYPE, cards, paper. **THE PRESS CO.** D-47 Meriden, Conn.

Mesco Telegraph Practice Set

For Learning Telegraph Codes

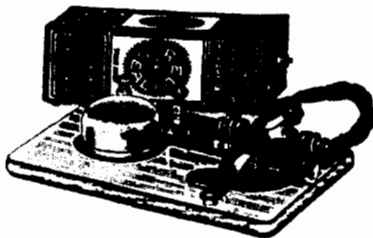

The Practice Set comprises a regular telegraph key, without circuit breaker, a special high pitch buzzer, one cell Red Seal Dry Battery, and four feet of green silk covered flexible cord.

The key and buzzer are mounted on a highly finished wood base, and three nickel plated binding posts are so connected that the set may be used for five different purposes. List No. Price

342 Telegraph Practice Set, with Battery and Cord.....\$3.24

Weights 4 lbs. packed. Price does not include postage.

MESCO Combination Practice Set for learning the Morse and Continental Visual and Audible Codes



This outfit is the only reliable instrument which will enable students to become proficient operators in the U. S. Naval Service, because it is equipped with a buzzer and miniature lamp enabling the user to master both the visual and audible signals quickly. List No. 33—Practice Set with Red Seal Battery and Cord.....\$4.00

Weights 4 lbs. packed. Price does not include postage.

Send for the New Edition of Our Catalog W28

It is pocket size, contains 248 pages, with over 1,000 illustrations, and describes in plain, clear language all about Bells, Post Offices, Batteries, Telephones and Telegraphs, Meters, Electric Toys, Burglar and Fire Alarm Conductions, Electric Call Bells, Electric Alarm Clocks, Medical Batteries, Motor Seal Horns, Electrically Heated Appliances, Battery Chargers, Surface Batteries, Gasoline Wireless Telegraph Instruments, Ignition Supplies, etc.

Send for the Catalog Now

Manhattan Electrical Supply Co., Inc.

NEW YORK: 17 Park Place CHICAGO: 116 S. Wells St. ST. LOUIS: 914 Pine St.
San Francisco Office: 904 Mission St.

MECHANICALLY RIGHT—A REAL LATHE

A Regular lathe, not a toy



Swing 4 inches, 11 inches between centers, 17 inches total length. Net weight 9 lbs. Shipping weight 15 lbs. The bed of this lathe is machined. Workmanship is first class throughout. Lathe comes equipped with wood turning chuck. Lathe can be fitted with 3/4 inch face plate and drill chuck as special equipment. Order one today. Price \$5.00 cash with order.

SYPHER MFG. CO., Dept. C., TOLEDO, OHIO

Feldman's "Geyser" Electric Water Heater

Instantaneous Hot Water

FELDMAN MFG. CO.

1500 Times Bldg. New York City

HAVE You SENT

for our booklet No. 4, giving diagrams and experiments with the Steco Battery?

STECO, 2134 N. Clark St., Chicago, Ill.

FAMOUS SCIENTIFIC ILLUSIONS.

(Continued from page 728)

$\frac{nqh}{nr(nr+h)} = \frac{qh}{r(nr+h)}$. Thus the difference of potential between the point of the pin and the medium around the same

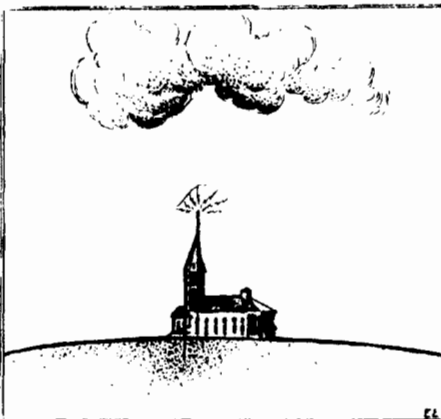

Fig. 4. Tesla Explains the Fallacy of the Franklin Pointed Lightning Rod, Here Illustrated, and Shows that Usually Such a Rod Could Not Draw Off the Electricity in a Single Cloud in Many Years. The Density of the Dots Indicates the Intensity of the Charges.

will be smaller in the ratio $\frac{r+h}{nr+h}$ when

the large sphere is used. In many scientific tests and experiments this important observation has been disregarded with the result of causing serious errors. Its significance is that the behavior of the pointed rod entirely depends on the linear dimensions of the electrified body. Its quality to give off the charge may be entirely lost if the latter is very large. For this reason, all points or projections on the surface of a conductor of such vast dimensions as the earth would be quite ineffective were it not for other influences. These will be elucidated with reference to Fig. 4, in which our artist of the Impressionist school has emphasized Franklin's notion that his rod was drawing electricity from the clouds. If the earth were not surrounded by an atmosphere which is generally oppositely charged it would behave, despite all its irregularities of surface, like a polished sphere. But owing to the electrified masses of air and cloud the distribution is greatly modified. Thus in Fig. 4,

the positive charge of the cloud induces in the earth an equivalent *opposite* charge, the density at the surface of the latter diminishing with the cube of the distance from the static center of the cloud. A brush discharge is then formed at the point of the rod and the action Franklin anticipated takes place. In addition, the surrounding air is ionized and rendered conducting and, eventually, a bolt may hit the building or some other object in the vicinity. The virtue of the pointed end to dissipate the charge, which was uppermost in Franklin's mind is, however, infinitesimal. *Careful measurements show that it would take many years before the electricity stored in a single cloud of moderate size would be drawn off or neutralized thru such a lightning conductor.* The grounded rod has the quality of rendering harmless most of the strokes it receives, tho occasionally the charge is diverted with damaging results. But, what is very important to note, it invites danger and hazard on account of the fallacy involved in its design. The sharp point which was thought advantageous and indispensable to its operation, is really a defect detracting considerably from the practical value of the device. I have produced a much improved form of lightning protector characterized by the employment of a terminal of considerable area and large radius of curvature which makes impossible undue density of the charge and ionization of the air.* *These protectors act as quasi-repellents and so far have never been struck tho exposed a long time.* Their safety is experimentally demonstrated to greatly exceed that invented by Franklin. By their use property worth millions of dollars which is now annually lost, can be saved.

III. The Singular Misconception of the Wireless.

To the popular mind this sensational advance conveys the impression of a single invention but in reality it is an art, the successful practise of which involves the employment of a great many discoveries and improvements. I viewed it as such when I undertook to solve wireless problems and it is due to this fact that my insight into its underlying principles was clear from their very inception.

In the course of development of my induction motors it became desirable to operate them at high speeds and for this purpose I constructed alternators of relatively

*Refer to the October, 1918, issue of this journal wherein Dr. Tesla's new form of non-pointed lightning rod was fully described and illustrated.

(Continued on page 732)

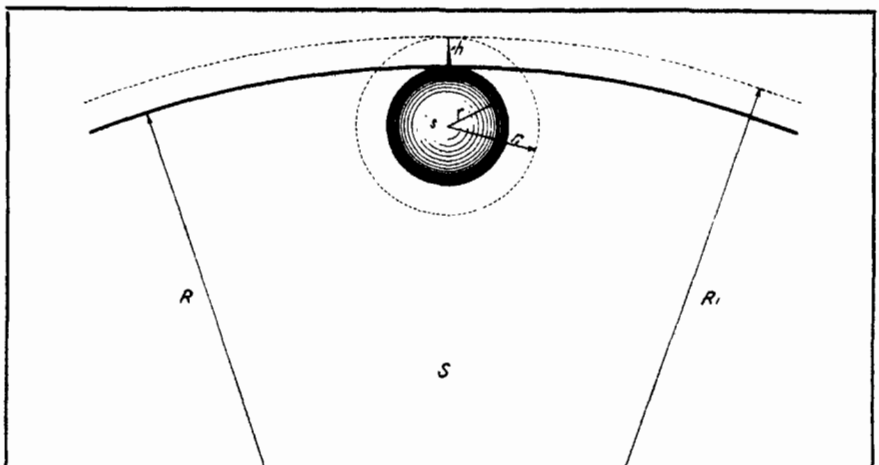

Fig. 3

Diagram Used to Explain the Fallacy of the Franklin Pointed Lightning Rod, and an Analogy Whereby the Author Shows in a Clear Manner How the Charged Sphere May for Illustration be Considered as Heated to a High Degree, and the Heat Allowed to Escape at a Known Rate

You can be quickly cured, if you

STAMMER

Send 10 cents coin or stamps for 70-page book on Stammering and Stuttering, "Its Cause and Cure." It tells how I cured myself after stammering for 30 years.
Benjamin N. Bogus, 761 Borne Building, Indianapolis

With the consent of **NIKOLA TESLA**

We have prepared a genuine, handsome photograph, autographed in facsimile by the great inventor. This photograph, taken in December, 1918, was posed especially for the cover design of the February, 1919, issue of the "Electrical Experimenter". It shows Tesla as he is today, holding his famous wireless-lighted globe. No advertising whatsoever on this photo, except for the autograph. Size about 9 x 12". Ready for framing. A striking picture of the world's greatest inventor for your den, library, laboratory, workshop or radio station. Sent prepaid in strong cardboard tube. Price \$1.00.

EXPERIMENTER PUBLISHING CO
231 Fulton St. Book Department N. Y. City

FAMOUS SCIENTIFIC ILLUSIONS

(Continued from page 730)

high frequencies. The striking behavior of the currents soon captivated my attention and in 1889 I started a systematic investigation of their properties and the possibilities of practical application. The first gratifying result of my efforts in this direction was the transmission of electrical energy thru *one wire* without return, of which I gave demonstrations in my lectures and addresses before several scientific bodies here and abroad in 1891 and 1892. During that period, while working with my oscillation transformers and dynamos of frequencies up to 200,000 cycles per second, the idea gradually took hold of me that the earth might be used in place of the wire, thus dispensing with artificial conductors altogether. The immensity of the globe seemed an unsurmountable obstacle but after a prolonged study of the subject I became satisfied that the undertaking was rational, and in my lectures before the Franklin Institute and National Electric Light Association early in 1893 I gave the outline of the system I had conceived. In the latter part of that year, at the Chicago World's Fair, I had the good fortune of meeting Prof. Helmholtz to whom I explained my plan, illustrating it with experiments. On that occasion I asked the cele-

brated physicist for an expression of opinion on the feasibility of the scheme. He stated unhesitatingly that it was practicable, provided I could perfect apparatus capable of putting it into effect but this, he anticipated, would be extremely difficult to accomplish.

I resumed the work very much encouraged and from that date to 1896 advanced slowly but steadily, making a number of improvements the chief of which was my system of *concatenated tuned circuits* and method of regulation, now universally adopted. In the summer of 1897 Lord Kelvin happened to pass thru New York and honored me by a visit to my laboratory where I entertained him with demonstrations in support of my wireless theory. He was fairly carried away with what he saw but, nevertheless, condemned my project in emphatic terms, qualifying it as something impossible, "an illusion and a snare." I had expected his approval and was pained and surprised. But the next day he returned and gave me a better opportunity for explanation of the advances I had made and of the true principles underlying the system I had evolved. Suddenly he remarked with evident astonishment: "Then you are not making use of Hertz waves?" "Certainly not," I replied, "these are radiations. No energy could be economically transmitted to a distance by any such agency. In my system the process is one of *true conduction* which, theoretically, can be effected at the greatest distance without appreciable loss." I can never forget the magic change that came over the illustrious philosopher the moment he freed himself from that erroneous impression. The skeptic who would not believe was suddenly transformed into the warmest of supporters. He parted from me not only thoroughly convinced of the scientific soundness of the idea but strongly express his confidence in its success. In my exposition to him I resorted to the following mechanical analogues of my own and the Hertz wave system.

Imagine the earth to be a bag of rubber filled with water, a small quantity of which is periodically forced in and out of the same by means of a reciprocating pump, as illustrated. If the strokes of the latter are effected in intervals of more than one hour and forty-eight minutes, sufficient for the transmission of the impulse thru the whole mass, the entire bag will expand and contract and corresponding movements will be imparted to pressure gauges or movable pistons with the same intensity, irrespective of distance. By working the pump faster, shorter waves will be produced which, on reaching the opposite end of the bag, may be reflected and give rise to stationary nodes and loops, but in any case, the fluid being incompressible, its inclosure perfectly elastic, and the frequency of oscillations not very high, the energy will be economically transmitted and very little power consumed so long as no work is done in the receivers. This is a crude but correct representation of my wireless system in which, however, I resort to various refinements. Thus, for instance, the pump is made part of a resonant system of great inertia, enormously magnifying the force of the impress impulses. The receiving devices are similarly conditioned and in this manner the amount of energy collected in them vastly increased.

The Hertz wave system is in many respects the very opposite of this. To explain it by analogy, the piston of the pump is assumed to vibrate to and fro at a terrific rate and the orifice thru which the fluid passes in and out of the cylinder is reduced to a small hole. There is scarcely any movement of the fluid and almost the whole work performed results in the production of radiant heat, of which an infinitesimal part is recovered in a remote locality. However incredible, it is true that

Wireless Stations Will Shortly Re-open Date, only, uncertain

Heed Our Advice

ORDER NOW

As a matter of law Congress loses all control over wireless receiving stations and transmitting stations with a range within the borders of the state where located as soon as peace is declared. The Radio Inspector of this district has already asked our co-operation in printing in the next edition of our catalog the necessity of securing licenses for transmitting sets with a range beyond the borders of the state. No wireless manufacturer wants the stations to open tomorrow. They could not take care of the business. Order now and be prepared.

We have a big stock of wireless instruments.

No. 11 is our latest catalog. No new price list.

Please do not write for catalog if you have No. 11. Paper costs three times as much as formerly. Let the amateur without a catalog secure one. Write for prices in advance. Just now we have no price list, because the changes have been so frequent. Will advise through this magazine when revised price list is ready, which will be as quickly as possible.

Send 8c in coin or stamps today for our big 300 page No. 11 Electrical and Wireless Catalog. Any wireless amateur will tell you it is the one catalog to have. You need no others. Our catalog contains most everything in wireless worth while, and is a guarantee that the goods are dependable.

THE WILLIAM B. DUCK CO., 230-232 Superior St., Toledo, Ohio

"THERE'S MONEY IN IT"

AT HOME LEARN TELEGRAPHY AT HOME MORSE AND WIRELESS

TEACH YOURSELF

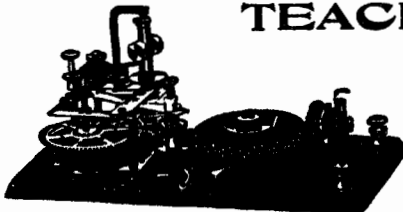

In half the usual time, at trifling cost, with the wonderful Automatic Transmitter, THE OMNIGRAPH. Sends unlimited Morse or Continental messages, at any speed, just as an expert operator would.

Adopted by U. S. Gov't. 4 styles. Catalogs free.

OMNIGRAPH MFG. CO.
39L Cortlandt St. New York

MAGNETIC RECTIFIER

Patented April 18, 1916



The F-F Battery Booster

For Home Charging of Storage Batteries

AUTOMOBILE OWNERS: Eliminate your starting and lighting troubles by the use of an F-F BATTERY BOOSTER in your own garage, without breaking any electrical connections or removing battery from car. Keeps your battery 100% efficient and prolongs its life indefinitely at a cost of about six cents a month. Write for bulletin No. 12 today.

The French Manufacturing Company
Cleveland, Ohio U. S. A.

February, 1919

ELECTRICAL EXPERIMENTER

the minds of some of the ablest experts have been from the beginning, and still are, obsessed by this monstrous idea, and so it comes that the true wireless art, to which I laid the foundation in 1893, has been retarded in its development for twenty years. This is the reason why the "statics" have proved unconquerable, why the wireless shares are of little value and why the Government has been compelled to interfere.

We are living on a planet of well-nigh inconceivable dimensions, surrounded by a layer of insulating air above which is a rarefied and conducting atmosphere (Fig. 5). This is providential, for if all the air were conducting the transmission of electrical energy thru the natural media would be impossible. My early experiments have shown that currents of high frequency and great tension readily pass thru an atmosphere but moderately rarefied, so that the insulating stratum is reduced to a small thickness as will be evident by inspection of Fig. 6, in which a part of the earth and its gaseous envelope is shown to scale. If the radius of the sphere is $12\frac{1}{2}$, then the non-conducting layer is only $1/64$ " thick and it will be obvious that the Hertzian rays cannot traverse so thin a crack between two conducting surfaces for any considerable distance, without being absorbed. The theory has been seriously advanced that these radiations pass around the globe by *successive reflections*, but to show the absurdity of this suggestion reference is made to Fig. 7 in which this process is diagrammatically indicated. Assuming that there is no refraction, the rays, as shown on the right, would travel along the sides of a polygon drawn around the solid, and inscribed into the conducting gaseous boundary in which case the length of the side would be about 400 miles. As one-half the circumference of the earth is approximately 12,000 miles long there will be, roughly, thirty deviations. The efficiency of such a reflector cannot be more than 25 per cent, so that if none of the energy of the transmitter were lost in other ways, the part recovered would be measured by the fraction $(\frac{1}{4})^{30}$. Let the transmitter radiate Hertz waves at the rate of 1,000 kilowatts. Then about one hundred and fifteen billionth part of one watt is all that would be collected in a perfect receiver. In truth, the reflections would be much more numerous as shown on the left of the figure, and owing to this and other reasons, on which it is unnecessary to dwell, the amount recovered would be a vanishing quantity.

Consider now the process taking place in the transmission by the instrumentalities and methods of my invention. For this purpose attention is called to Fig. 8, which gives an idea of the mode of propagation of the current waves and is largely self-explanatory. The drawing represents a solar eclipse with the shadow of the moon just touching the surface of the earth at a point where the transmitter is located. As the shadow moves downward it will spread over the earth's surface, first with infinite and then gradually diminishing velocity until at a distance of about 6,000 miles it will attain its true speed in space. From there on it will proceed with increasing velocity, reaching infinite value at the opposite point of the globe. It hardly need be stated that this is merely an illustration and not an accurate representation in the astronomical sense.

The exact law will be readily understood by reference to Fig. 9, in which a transmitting circuit is shown connected to earth and to an antenna. The transmitter being in action, two effects are produced: Hertz waves pass thru the air, and a current traverses the earth. The former propagate with the speed of light and their energy is unrecoverable in the circuit. The latter precedes with the speed varying as the cosecant of the angle which a radius drawn from any point under consideration forms

Increase Your Will Power In One Hour

Author of This Article Tells How He Quickly Acquired a Dominating Will Power That Earns Him Between \$50,000 and \$70,000 a Year

FOUR YEARS ago a man offered me a wonderful bargain. He was hard up for money and wanted to sell me some shares in a young, growing company for \$1,000. Based on the earnings of the Company the stock offered me was easily worth \$5,000—in fact, the man who finally bought the shares sold them again in five months at a profit of \$4,300.

The reason I didn't buy the shares was that I could no more raise a thousand dollars than I could hop, skip, and jump across the Atlantic Ocean. A thousand dollars! And my income only twenty-five a week.

The second chapter in my life began a few months later, when another opportunity came to me. It required an investment of \$20,000 during the first year. I raised the money easily, paid back every penny I borrowed, and had \$50,000 left at the end of the first year! To date, in less than four years, my business has paid me a clear profit of \$200,000 and is now earning between \$50,000 and \$70,000 a year. Yet for two years and seven months, the company had been losing money every year!

The natural question for my reader to ask is, "How could you borrow \$20,000 to invest in a business which had previously been a failure, after being unable to borrow \$1,000 for an investment that seemed secure?" It is a fair question. And the answer can be given in two little words—WILL POWER.

When the first proposition came to me I passed it by simply because I didn't have the money and couldn't borrow it. I went from one friend to the next and all turned me down. Several refused to talk business with me at all. They all liked me personally, and they asked me about the kiddies, but when it came to money matters I hadn't a chance. I was scared stiff every time I talked to one of them. I pleaded with them, almost begged them. But everybody had their "money all tied up in other investments." It was an old excuse, but I accepted it meekly. I called it hard luck. But I know today that it was nothing in the world except my lack of Will Power, or rather my weak Will Power, which kept me from getting what I wanted.

When I heard that the man sold those shares at a profit of \$4,300, it seemed that my sorrow could not be greater. My profit was just about what my salary amounted to for four years! But instead of grieving over my "hard luck," I decided to find out why I was so easily beaten in everything I tried to accomplish. It must be that there was something vital that made the difference between success and failure. It wasn't lack of education, for many illiterate men become wealthy. What was this vital spark? What was this one thing which successful men had and which I did not have?

I began to read books about psychology and mental power. But everything I read was too general. There was nothing definite—nothing that told me what to do.

After several months of discouraging effort, I finally encountered a book called "Power of Will," by Prof. Frank Channing Haddock. The very title came to me as a shock. When I opened the book I was amazed. I realized that will power was the vital spark—the one thing that I lacked.

And here in this book were the very rules, lessons and exercises through which anyone could increase their will power. Eagerly I read page after page, including such articles as, The Law of Great Thinking; How to Develop Analytical Power; How to Concentrate Perfectly; How to Guard Against Errors in Thought; How to Develop Fearlessness; How to Acquire a Dominating Personality.

An hour after I opened the book I felt like a new person. My sluggish will power was beginning to awaken. There was a new light in my eye, a new spring in my step, a new determination in my soul. I began to see, in my past, the many mistakes I had made, and I knew I would never make them again.

I practiced some of the simple exercises. They were more fascinating than any game of cards or any sport.

Then came an opportunity to acquire the business which had lost money for twelve years, and which I turned into a \$50,000 a year money maker. Instead of crying before the moneyed people, I won them over by my sheer force of will. I would not be denied. And my every act and word since then has been the result of my training in will power.

I am convinced that every man has within himself every essential quality of success except a strong will. Any man who doubts that statement need only analyze the successful men he knows, and he will find himself their equal, or their superior, in every way except in will power. Without a strong will, education counts for little, money counts for nothing, opportunities are useless.

I earnestly recommend Prof. Haddock's great work, "Power of Will," to those who feel that success is just out of reach—to those who lack that something which they cannot define, yet which holds them down to the grind of a small salary.

Never before have business men and women needed this help so badly as in these trying times. Hundreds of real and imaginary obstacles confront us every day, and only those who are masters of themselves and who hold their heads up will succeed. "Power of Will" as never before is an absolute necessity—an investment in self-culture which no one can afford to deny himself.

I am authorized to say that any reader who cares to examine "Power of Will" for five days may do so without sending any money in advance. If after one hour you do not feel that your will power has increased, and if after a week's reading you do not feel that this great book supplies that one faculty you need most to win success, return it and you will owe nothing. Otherwise send only \$3, the small sum asked.

Some few doubters will scoff at the idea of will power being the fountainhead of wealth, position and everything we are striving for, but the great mass of intelligent men and women will at least investigate for themselves by sending for the book at the publisher's risk. I am sure that any book that has done for me—and for thousands of others—what "Power of Will" has done—is well worth investigating. It is interesting to note that among the 250,000 owners of "Power of Will" are such prominent men as Supreme Court Justice Parker; Wu Ting Fang, Ex-U. S. Chinese Ambassador; Gov. McKelvie, of Nebraska; Assistant Postmaster-General Britt; General Manager Christenson, of Wells-Fargo Express Co.; E. St. Elmo Lewis; Senator Arthur Capper of Kansas and thousands of others. In fact, today "Power of Will" is just as important, and as necessary to a man's or woman's equipment for success, as a dictionary. To try to succeed without Power of Will is like trying to do business without a telephone.

As your first step in will training, I suggest immediate action in this matter before you. It is not even necessary to write a letter. Use the form below, if you prefer, addressing it to the Pelton Publishing Company, 30-B Wilcox Block, Meriden, Conn., and the book will come by return mail. You hold in your hand, this very minute, the beginning of a new era in your life. Over a million dollars has been paid for "Power of Will" by people who sent for it on free examination. Can you, in justice to yourself, hesitate about sending in the coupon? Can you doubt, blindly, when you can see, without a penny deposit, this wonder-book that will increase your will power in one hour.

The cost of paper, printing and binding has almost doubled during the past few years, in spite of which "Power of Will" has not been increased in price. The publisher feels that so great a work should be kept as low-priced as possible, but in view of the enormous increase in the cost of every manufacturing item, the present edition will be the last sold at the present price. The next edition will cost more. I urge you to send in the coupon now.

PELTON PUBLISHING COMPANY
30-B Wilcox Block, Meriden, Conn.

I will examine a copy of "Power of Will," at your risk I agree to remit \$3 or return book in 5 days.

Name.....
Address.....
City..... State.....

Partial List of Contents

The Law of Great Thinking
The Four Factors on which it depends
How to develop analytical power.
How to think "all around" any subject.
How to throw the mind into deliberate, controlled, productive thinking.
Detailed directions for Perfect Mind Concentration.
How to acquire the power of Consecutive Thinking, Reasoning, Analysis.
How to acquire the skill of Creative Writing.
How to guard against errors in Thought.
How to drive from the mind all unwelcome thoughts.
How to follow any line of thought with keen, concentrated Powers.
How to develop Reasoning Power.
How to handle the mind in Creative Thinking.
The secret of Building Mind Power.
How the Will is made to act.
How to test your Will.
How a Strong Will is Master of Body.
What creates Human Power.
The Six Principles of Will Training.
Definite Methods for developing Will.
THE SIXTY-NINE METHODS for using Will Power in the Conduct of Life.
Seven Principles of drill in Mental, Physical, Personal power.
FIFTY-ONE MAXIMS for Applied Power of Perception, Memory, Imagination, Self-Analysis, Control.
How to develop a strong, keen gaze.
How to concentrate the eye upon what is before you—object, person, printed page, work.
These are only a few of the many subjects treated.

1/4 H.P., 110 volts, A.C. 60 cycle, single phase, 1750 R.P.M.

MOTORS

We have 1000 NEW WASHING MACHINE MOTORS. These are of standard manufacture and carry the regular factory guarantee. Shipped in original boxes. Complete as cut.

Bought from Bankruptcy Stock

Suitable for operating Coffee Grinders, Cream Separators, Bottle Washers, Air Compressors, Small Lathes, Etc.

Mail \$3.00 cash or Money Order. We will send C.O.D. subject to full examination.

\$18.50 EACH

Special Quantity Prices Regular Value \$24

MANUFACTURERS' DISTRIBUTOR

CHAS. H. JOHNSTON - West End - Pittsburgh, Pa.

BARAINS In Small Motors and Generators Write for Catalogue.

with the axis of symmetry of the waves. At the origin the speed is infinite but gradually diminishes until a quadrant is traversed, when the velocity is that of light. From there on it again increases, becoming infinite at the antipole. Theoretically the energy of this current is recoverable in its entirety, in properly attuned receivers.

Some experts, whom I have credited with better knowledge, have for years contended that my proposals to transmit power without wires are sheer nonsense but I note that they are growing more cautious every day. The latest objection to my system is found in the cheapness of gasoline. These men labor under the impression that the energy flows in all directions and that, therefore, only a minute amount can be recovered in any individual receiver. But this is far from being so. The power is conveyed in only one direction, from the transmitter to the receiver, and none of it is lost elsewhere. It is perfectly practicable to recover at any point of the globe energy enough for driving an airplane, or a pleasure boat or for lighting a dwelling. I am especially sanguine in regard to the lighting of isolated places and believe that a more economical and convenient method can hardly be devised. The future will show whether my foresight is as accurate now as it has proved heretofore.

SHIP RADIO OPERATORS ASK INCREASED WAGES.

Increased wages and the fixing of a standard wage scale for radio operators on vessels operating under Government direction was asked of the Shipping Board recently by a delegation representing the Marconi Radio Telegraphers' Association. The radio operators included in the request made of the Board are those on vessels operating in transatlantic and Gulf waters. Assurances were given the radio representatives by Board officials that their request would be taken under advisement for immediate consideration.

Wireless Taught By Mail

Merchant Marine Needs THOUSANDS of Operators

Men also needed for big Land Wireless Stations—Aerial Mail Service—Railroad and Telegraph companies. Salaries up to \$200 a month. Excellent opportunities to win promotion to Radio Engineer—Inspector—Or Draftsman. Chance to travel the world over or locate at Land Station in America.

Complete Course by Mail in Ten Weeks

Our students actually pass the commercial examination in Ten Weeks or less. Start studying NOW in spare time at home. We send you Complete Set Practice Instruments for receiving and sending messages, with first lessons. We help you secure position in any branch of Commercial or Government Radio Service. Write TODAY for Free Particulars. A postal will do.

NATIONAL RADIO INSTITUTE
Dept. 68 Washington, D. C.

Grinding and Buffing Motors

An indispensable tool in any shop or laboratory. Your equipment is not complete without a BODINE grinding and buffing motor. Save time and money by keeping your lathe tools, milling cutters and drills sharp.

Send for bulletin No. 522 giving full details of this handy machine.

BODINE ELECTRIC COMPANY, 2254 W. Ohio St., Chicago.

SKINDERVIKEN TRANSMITTER BUTTON



Fig. 1



Fig. 2

THE SKINDERVIKEN TRANSMITTER BUTTON presents the latest advance in microphones and marks a revolution in transmitter construction. It works on an entirely new principle, takes up practically no room, and marks

with surprising clarity. Fig. 3 illustrates the same arrangement placed on the chest as shown. In this position the transmitter will talk clearly and loudly. Fig. 4 shows an arrangement whereby the Skinderviken button is attached on a thin wood board at the preacher's pulpit. His voice is clearly transmitted so that people hard of hearing can readily hear the sermon. Fig. 5 shows an interesting stunt, whereby a hole is drilled in the side of a thin glass water-tumbler; the sides of the glass thus acting as a diaphragm, the voice is clearly transmitted. Fig. 6 shows a simple match box Detectophone. The Skinderviken button is concealed inside of the box, only the small brass nut showing on the outside. This can be camouflaged as well. This device talks well. Fig. 7 shows how to transmit phonograph music at a distance merely by drilling a small hole in the phonograph arm and attaching the Skinderviken button; a very favorite experiment with all experimenters. Fig. 8 shows how a very sensitive Detectophone can be made by placing one of the buttons in the center of a lithographed cardboard picture, so that only the small brass nut shows. The large surface of the picture acts as a big diaphragm, and the voice is well reproduced.



\$1.00 prepaid



Fig. 3



Fig. 4



Fig. 5



Fig. 6



Fig. 7



Fig. 8

We have such unlimited confidence in the Skinderviken transmitter button that we make the following remarkable offer. Send us one dollar (\$1.00) for which we will mail you button prepaid. If you do not wish to keep it, return it within two days and your money will be refunded. Boys! send stamp for booklet No. 4. It gives diagrams and experiments using the Skinderviken Transmitter Button, and prices of telephone equipment.

SKINDERVIKEN TELEPHONE EQUIPMENT CO.

Address us as **STECO, 2134 N. Clark St., Chicago, Ill.**

New York Tribune
Feb. 23, 1919

Tesla answers Mr. Manierre and further explains the axial rotation of the moon.

Sirs:

In your article of February 2, Mr. Charles E. Manierre, commenting upon my article in "The Electrical Experimenter" for February, which appeared in The Tribune of January 26, suggests that I give a definition of axial rotation.

I intended to be explicit on this point, as may be judged from the following quotation: "The unfailing test of the spinning of a mass is, however, the existence of energy of motion. The moon is not possessed of such vis viva." By this I meant that "axial rotation" is not simply "rotation upon an axis" as nonchalantly defined in dictionaries, but is circular motion in the true physical sense - that is, one in which half the product of the mass with the square of velocity is a definite and positive quantity.

The moon is a nearly spherical body, of a radius of about 1,081.5 miles, from which I calculate its volume to be approximately 5,300,216,300 cubic miles. Since its mean density is 3.27, one cubic foot of material composing it weighs close to 205 pounds. Accordingly, the total weight of the satellite is about 79,969,000,000,000,000,000,000 and its mass 2,483,500,000,000,000,000 terrestrial short tons. Assuming that the moon does physically rotate upon its axis, it performs one revolution in 27 days 7 hours 43 minutes and 11 seconds, or 2,360,591 seconds. If, in conformity with mathematical principles, we imagine the entire mass concentrated at a distance from the centre equal to two-fifths of the radius, then the calculated rotational velocity is 3.04 feet per second, at which the globe would contain 11,474,000,000,000,000,000 short foot tons of energy, sufficient to run 1,000,000,000 horsepower for a period of 1,323 years. Now, I say that there is not enough energy in the moon to run a delicate watch.

In astronomical treatises usually the argument is advanced that "if the lunar globe did not turn upon its axis it would expose all parts to terrestrial view. As only a little over one-half is visible it must rotate." But this inference is erroneous, for it admits of one alternative. There are an infinite number of axes besides its own on each of which the moon might turn and still exhibit the same peculiarity.

I have stated in my article that the moon rotates about an axis, passing through the centre of the earth, which is not strictly true, but does not vitiate the conclusions I have drawn. It is well known, of course, that the two bodies revolve around a common centre of gravity which is at a distance of a little over 2,899 miles from the earth's centre.

Another mistake in books on astronomy is made in considering this motion equivalent to that of a weight whirled on a string or in a sling. In the first place, there is an essential difference between these two devices though involving the same mechanical principle. If a metal ball attached to a string is whirled around and the latter breaks an axial rotation of the missile results which is definitely related in magnitude and direction to the motion preceding. By way of illustration: If the ball is whirled on the string clockwise, ten times a second, then when it flies off it will rotate on its axis twenty times a second, likewise in the direction of the clock. Quite different are the conditions when the ball is thrown from a sling. In this case a much more rapid rotation is imparted to it in the opposite sense. There is not true analogy to these in the motion of the moon. If the gravitational string, as it were, would snap, the satellite would go off in a tangent without the slightest swerving or rotation, for there is no momentum about the

axis and, consequently, no tendency whatever to spinning motion.

Mr. Manierre is mistaken in his surmise as to what would happen if the earth were suddenly eliminated. Let us suppose that this would occur at the instant when the moon is in opposition. Then it would continue on its elliptical path around the sun, presenting to it steadily the face which was always exposed to the earth. If, on the other hand, the latter would disappear at the moment of conjunction, the moon would gradually swing around through 180 degrees and, after a number of oscillations, revolve again with the same face to the sun. In either case there would be no periodic changes, but eternal day and night, respectively, on the sides turned toward and away from the luminary.

NIKOLA TESLA

The Moon's Rotation

By NIKOLA TESLA

SINCE the appearance of my article entitled the "Famous Scientific Illusions" in your February issue, I have received a number of letters criticizing the views I express regarding the moon's "axial rotation." These have been partly answered by my statement to the *New York Tribune* of February 23, which allow me to quote:

In your issue of February 2, Mr. Charles E. Manierre, commenting upon my article in the *Electrical Experimenter* for February which appeared in the *Tribune* of January 26, suggests that I give a definition of axial rotation.

I intended to be explicit on this point as may be judged from the following quotation: "The unflinching test of the spinning of a mass is, however, the existence of *energy of motion*. The moon is not possest of such *vis viva*." By this I meant that "axial rotation" is not simply "rotation upon an axis nonchalantly defined in dictionaries, but is a circular motion in the true physical sense—that is, one in which half the product of the mass with the square of velocity is a definite and positive quantity. The moon is a nearly spherical body, of a radius of about 1,087.5 miles, from which I calculate its volume to be approximately 5,300,216,300 cubic miles. Since its mean density is 3.27, one cubic foot of material composing it weighs close on 205 lbs. Accordingly, the total weight of the satellite is about 79,969,000,000,000,000,000, and its mass 2,483,500,000,000,000,000 terrestrial short tons. Assuming that the moon does physically rotate upon its axis, it performs one revolution in 27 days, 7 hours, 43 minutes and 11 seconds, or 2,360,591 seconds. If, in conformity with mathematical principles, we imagine the entire mass concentrated at a distance from the center equal to two-fifths of the radius, then

In astronomical treatises usually the argument is advanced that "if the lunar globe did not turn upon its axis it would expose all parts to terrestrial view. As only a little over one-half is visible it *must* rotate." But this inference is erroneous, for it only admits of

one alternative. There are an infinite number of axis besides its own in each of which the moon might turn and still exhibit the same peculiarity.

I have stated in my article that the moon rotates about an axis passing thru the center of the earth, which is not strictly true, but it does not vitiate the

conclusions I have drawn. It is well known, of course, that the two bodies revolve around a common center of gravity, which is at a distance of a little over 2,899 miles from the earth's center.

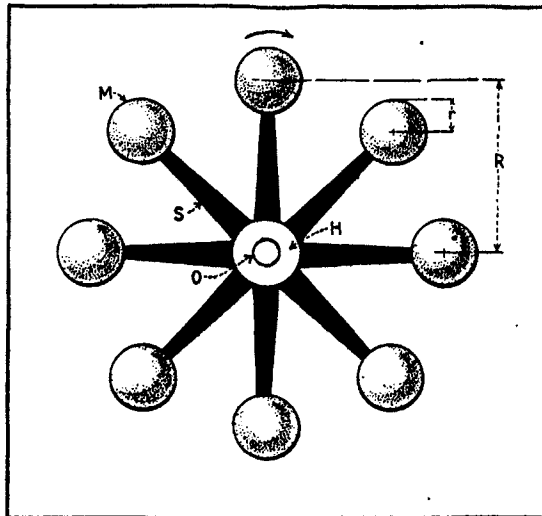

If You Still Think That the Moon Rotates on Its Axis, Look at This Diagram and Follow Closely the Successive Positions Taken by One of the Balls M While It Is Rotated by a Spoke and the Analogy Solves the Moon Rotation Riddle.

Another mistake in books on astronomy is made in considering this motion equivalent to that of a weight whirled on a string or in a sling. In the first place there is an essential difference between these two devices both involving the same mechanical principle. If a metal ball, attached to a string, is whirled around and the latter breaks, an axial rotation of the missile results which is definitely related in magnitude

slung. In this case a *much more rapid* rotation is imparted to it in the *opposite sense*. There is no true analogy to these in the motion of the moon. If the *gravitational string*, as it were, would snap, the satellite would go off in a tangent without the slightest swerving or rotation, for there is no moment about the axis and, consequently, no tendency whatever to spinning motion.

Mr. Manierre is mistaken in his surmise as to what would happen if the earth were suddenly eliminated. Let us suppose that this would occur at the instant when the moon is in *opposition*. Then it would continue on its elliptical path around the sun, presenting to it steadily the face which was always exposed to the earth. If, on the other hand, the latter would disappear at the moment of *conjunction*, the moon would gradually swing around thru 180° and, after a number of oscillations, revolve, again with the same face to the sun. In either case there would be no periodic changes but eternal day and night, respectively, on the sides turned towards, and away from, the luminary.

Some of the arguments advanced by the correspondents are ingenious and not a few comical. None, however, are valid.

One of the writers imagines the earth in the center of a circular orbital plate, having fixedly attached to its periphery a disk-shaped moon, in frictional or geared engagement with another disk of the same diameter and freely rotatable on a pivot projecting from an arm entirely independent of the planetary system. The arm being held continuously parallel to itself, the pivoted disk, of course, is made to turn on its axis as the orbital plate is rotated. This is a well-known drive, and the rotation of the pivoted disk is as palpable a fact as that of the orbital plate. But, the moon in this

model only revolves about the center of the system without the slightest angular displacement on its own axis. The same is true of a cart-wheel to which this writer refers. So long as it advances on the earth's surface it turns on the axle in the true physical sense; when one of its spokes is always kept in a perpendicular position the wheel still *revolves* about the earth's center, but *axial rotation has ceased*. Those who think that it then still exists are laboring under an illusion.

An obvious fallacy is involved in the following abstract reasoning. The orbital plate is assumed to gradually shrink, so that finally the

and direction to the motion preceding. By way of illustration—if the ball is whirled on the string clockwise ten times per second, then when it flies off, it will rotate on its axis ten times per second, likewise in the direction of a clock. Quite different are the conditions when the ball is thrown from a

centers of the earth and the satellite coincide when the latter revolves simultaneously about its own and the earth's axis. We may reduce the earth to a mathematical point and the distance between the two planets to the radius of the moon without affecting the system in principle, but a further diminution of the distance is mani- (Cont. on p. 892)

The Moon's Rotation

(Continued from page 866)

festly absurd and of no bearing on the question under consideration.

In all the communications I have received, tho different in the manner of presentation, the successive changes of position in space are mistaken for axial rotation. So, for instance, a positive refutation of my arguments is found in the observation that the moon exposes all sides to other planets! It revolves, to be sure, but none of the evidences is a proof that it turns on its axis. Even the well-known experiment with the Foucault pendulum, altho exhibiting similar phenomena as on our globe, would merely demonstrate a motion of the satellite about *some* axis. The view I have advanced is NOT BASED ON A THEORY but on facts demonstrable by experiment. It is not a matter of definition as some would have it. A MASS REVOLVING ON ITS AXIS MUST BE POSEST OF MOMENTUM. If it has none, there is no axial rotation, all appearances to the contrary notwithstanding.

A few simple reflections based on well establish mechanical principles will make this clear. Consider first the case of two equal weights w and w_1 , in Fig. 1, whirled about the center O on a string s as shown. Assuming the latter to break at a both weights will fly off on tangents to their circles of gyration, and, being animated with different velocities, they will rotate around their common center of gravity o . If the weights are whirled n times per second then the speed of the outer and the inner one will be, respectively, $V = 2(R+r)n$ and $V_1 = 2\pi(R-r)n$, and the difference $V - V_1 = 4\pi rn$, will be the length of the circular path of the outer weight. Inasmuch, however, as there will be equalization of the speeds until the mean $V - V_1$

consumed in the supposed axial rotation, which is, consequently, wholly illusionary. Something even more interesting may, however, be stated. As I have shown before, a ball flying off will rotate at the rate of the wheel and in the same direction. But this whirling motion, unlike that of a projectile, neither adds to, nor detracts from, the energy of the translatory movement which is exactly equal to the work consumed in giving to the mass the observed velocity.

From the foregoing it will be seen that in order to make one physical revolution on its axis the moon should have twice its present angular velocity, and then it would contain a quantity of stored energy as given in my above letter to the *New York Tribune*, on the assumption that the radius of gyration is $2/5$ that of figure. This, of course, is uncertain, as the distribution of density in the interior is unknown. But from the character of motion of the satellite it may be concluded with certitude that it is devoid of momentum about its axis. If it be bisected by a plane tangential to the

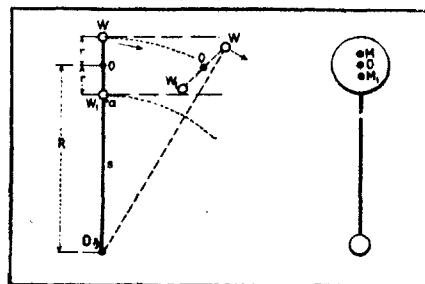

Diagram illustrating the Rotation of Weights Thrown Off By Centrifugal Force.

orbit, the masses of the two halves are inversely as the distances of their centers of gravity from the earth's center and, therefore, if the latter were to disappear suddenly, no axial rotation, as in the case of a weight thrown off, would ensue.

WHAT IS MAN?

A man weighing 150 pounds will contain approximately 3,500 cubic feet of gas,—oxygen, hydrogen and nitrogen in his constitution, which at eighty cents per thousand cubic feet would be worth \$2.80 for illuminating purposes. He also contains all the necessary fats to make a 15-pound candle, and thus, together with his 3,500 cubic feet of gases, he possesses considerable illuminating possibilities. His system contains 22 pounds and ten ounces of carbon, or enough to make 780 dozen, or 9,360 lead pencils. There are about fifty grains of iron in his blood and the rest of the body would supply enough of this metal to make one spike large enough to hold his weight. A healthy man contains 54 ounces of phosphorus. This deadly poison would make 800,000 matches, or enough poison to kill five hundred persons. This, with two ounces of lime, make the stiff bones and brains. No difference how *sour* a man looks, he contains about 60 pounds of sugar of the ordinary cubical dimensions, and to make the seasoning complete, there are 20 *spoonfuls of salt*. If a man were distilled into water, he would make about 38 quarts, or more than half his entire weight. He also contains a great deal of starch, chlorid of potash, magnesium, sulfur, and hydrochloric acid in his wonderful human system.

Break the shells of 1,000 eggs into a huge pan or basin, and you have the contents to make a man from his toe-nails to the most delicate tissues of his brain. And this is the scientific answer to the question, "What is Man?"



Tobacco Habit BANISHED in 48 to 72 Hours

No craving for tobacco in any form when you begin taking Tobacco Redeemer. Don't try to quit the tobacco habit unaided. It's a losing fight against heavy odds and means a serious shock to the nervous system. Let the tobacco habit quit YOU. It will quit you, if you will just take Tobacco Redeemer, according to directions for two or three days. It is a most marvelously quick and thoroughly reliable remedy for the tobacco habit.

Not a Substitute

Tobacco Redeemer contains no habit-forming drugs of any kind. It is in no sense a substitute for tobacco. After finishing the treatment you have absolutely no desire to use tobacco again or to continue the use of the remedy. It makes not a particle of difference how long you have been using tobacco, how much you use or in what form you use it—whether you smoke cigars, cigarettes, pipe, chew plug or fine cut or use snuff, Tobacco Redeemer will positively banish every trace of desire in from 48 to 72 hours. This we absolutely guarantee in every case or money refunded.

Write today for our free booklet showing the deadly effect of tobacco upon the human system and positive proof that Tobacco Redeemer will quickly free you of the habit.

Newell Pharmaceutical Company, Dept. 521 St. Louis, Mo.

BOYS!

Write For New AUTO-WHEEL BOOKLET, and

FREE FELT PENNANT

Send us the names of three coaster wagon dealers, mentioning which handle the AUTO-WHEEL, and we'll send you a beautiful Felt Pennant FREE and tell you all about the wonderful Auto-Wheel Coaster and the patented Auto-Wheel Convertible Roadster.

Wouldn't YOU Like to Organize a Coaster Club?

It's great fun. Every member receives a cap and the Captain a special cap. When you write, be sure to ask for full information and the new Auto-Wheel Booklet. It's brimful of information you should have.

The Buffalo Sled Co.

Dept. 163 N. Tawawanda, N. Y.

In Canada: Preston, Ont.

Get an



Auto-Wheel

BOYS BUILD THIS CAR

This nifty little car driven by gasoline motor can be built by any boy. Parts are furnished by us and are very cheap. Send 38 cents for building plans and price list of parts showing how to build this lads' car.



STYPER MFG. CO. 1126 Warren Street TOLEDO, OHIO.



BUSH CAR—FREE

This five passenger 37 H. P. car, 128 in. wheel base. All bearings Timken. Deice lamp, dynamo, etc. and lights. Write at once for my great Free Car and 42-page catalog. Agents wanted to drive and demonstrate. Territory open. Prompt shipments. No money. Address: J. M. Bush, President, Dept. 218 BUSH MOTOR CO., Bush Temple, Chicago, Illinois.

The Moon's Rotation

By NIKOLA TESLA

In this article Dr. Tesla proves conclusively by theory and experiment that all the kinetic energy of a rotating mass is purely translational and that the moon contains absolutely no rotational energy, in other words, does not rotate on its axis.—EDITOR.

IN revising my article on "The Moon's Rotation", which appeared in the April issue of the ELECTRICAL EXPERIMENTER, I appended a few remarks to the original text in further support and eluci-

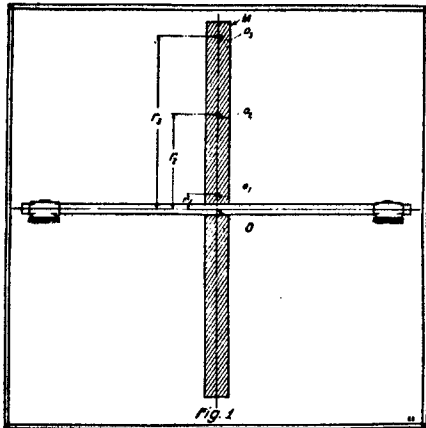

Fig. 1. In Determining the Kinetic Energy of a Rotating Mass, This Figure Shows the Selection of a Number of Points Taken Within the Straight Rod or Mass M, at Successive Distances from the Axis of Rotation O, Knowing These Values and the Speed of Rotation the Kinetic Energy of the Mass is Readily Computed.

dation of the theory advanced. Due to the printer's error these were lost and, in consequence, I found it necessary to forward another communication which, unfortunately, was received too late for embodiment in the May number. Meanwhile many letters have reached me in which certain phenomena presented by rotating bodies, as the moon's librations of longitude, are cited as evidences of energy due to spinning motion, i. e., proofs of axial rotation of the satellite in the true physical sense. I trust that the following amplified statement will meet all of the objections raised and convert to my views those who are still unconvinced.

The kinetic energy of a rotating mass can be determined in four ways which are illustrated in diagrams, Figs. 1, 2, 3 and 4 and may be found more or less suitable.

Referring to Fig. 1, the method consists in selecting judiciously a number of points as o_1, o_2, o_3 , etc., within the straight rod or mass M, respectively at distances r_1, r_2, r_3 , etc., from the axis of rotation O and calculating the square root of the mean square of these distances. Its value being R_g , denoted radius of gyration, the effective velocity of the mass at n revolutions per second will be $V_o = 2\pi R_g n$ and its kinetic energy $E = \frac{1}{2} M V_o^2 = \frac{1}{2} M (2\pi R_g n)^2$.

In Fig. 2 the mass M, rotating n times per second about an axis O at right angles to the plane of the paper, is divided into numerous elements or small parts, most conveniently very thin concentric laminae, as l_1, l_2, l_3 , etc., at distances r_1, r_2, r_3 , etc., from O. Since the kinetic energy of each part is equal to half the product of its mass and the square of the velocity, the sum of all these elemental energies $E = \frac{1}{2} \sum m V^2 = \frac{1}{2} m_1 V_1^2 + \frac{1}{2} m_2 V_2^2 + \frac{1}{2} m_3 V_3^2 + \dots = \frac{1}{2} m_1 (2\pi r_1 n)^2 + \frac{1}{2} m_2 (2\pi r_2 n)^2 + \frac{1}{2} m_3 (2\pi r_3 n)^2 + \dots$

A different form of expression for the energy of a rotating body may be obtained by determining its moment of inertia. For this purpose the mass M (in Fig. 3), rotating n times per second about an axis O, is separated into minute parts, as m_1, m_2, m_3 , etc., respectively at distances r_1, r_2, r_3 , etc., from the same. The sum of the products of all these small masses and the squares

of their distances is the moment of inertia I, and then $E = \frac{1}{2} I \omega^2, \omega = 2\pi n$ being the angular velocity.

It is obvious that in all these instances many points or elements will be required for great accuracy but, as a rule, very few are sufficient in practice.

Still another way to compute the kinetic energy is illustrated in Fig. 4, in which case the quantity I is given in terms of the moment of inertia I_c about another axis parallel to O and passing thru the center of gravity C of mass M. In conformity with this the energy of motion $E = \frac{1}{2} M V^2 + \frac{1}{2} I_c \omega^2$ in which equation V is the velocity of the center of gravity.

The preceding is deemed indispensable as I note that the correspondents, even those who seem thoroly familiar with mechanical principles, fail to make a distinction between theoretical and physical truths which is essential to my argument.

In estimating the kinetic energy of a rotating mass in any of the ways indicated we arrive, thru suitable conceptions and methods of approximation, at expressions which may be made quantitatively precise to any desired degree, but do not truly de-

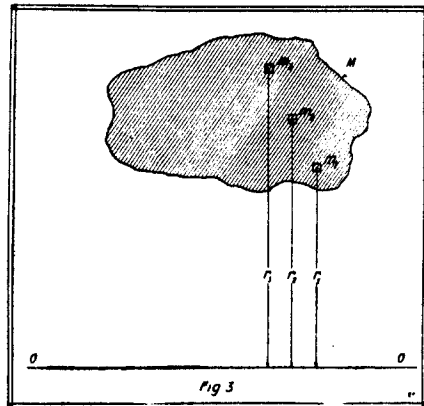

Fig. 3. Another Form of Expression for the Energy of a Rotating Body May Be Obtained by Determining Its Moment of Inertia. Here the Mass M is Subdivided into Minute Parts m_1, m_2, m_3 , etc. The Sum of the Products of These Masses and the Squares of Their Distances is the Moment of Inertia, Which with the Angular Speed, Gives the Kinetic Energy E.

fine the actual condition of the body. To illustrate, when proceeding according to the plan of Fig. 1, we find a certain hypothetical velocity with which the entire mass should

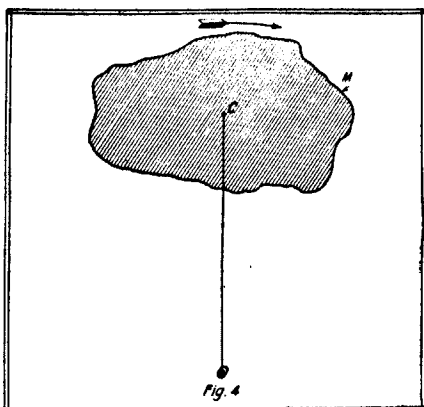

Fig. 4. In this Case the Motion is Resolved into Two Separate Components—One Translational About O and the Other Rotational About C. The Total Kinetic Energy of the Mass Equals the Sum of These Two Energies.

move in order to contain the same energy, a state wholly imaginary and irreconcilable with the actual. Only, when all particles of the body have the same velocity, does the

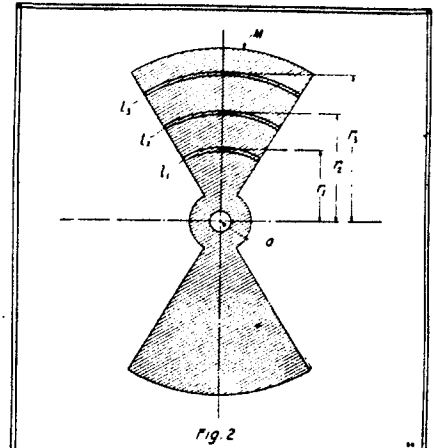

Fig. 2. In This Case the Mass M, Rotating n Times Per Second, About An Axis O, is Divided into Numerous Elements or Small Parts at Various Radii from O. Knowing the Kinetic Energy of Each Part, the Whole Kinetic Energy of the Mass is Easily Determined by Taking a Summation of the Individual Quantities.

product $\frac{1}{2} M V^2$ specify a physical fact and is numerically and descriptively accurate. Still more remote from palpable truth is the equation of motion obtained in the manner indicated in Fig. 4, in which the first term represents the kinetic energy of translation of the body as a whole and the second that of its axial rotation. The former would demand a movement of the mass in a definite path and direction, all particles having the same velocity, the latter its simultaneous motion in another path and direction, the particles having different velocities. This abstract idea of angular motion is chiefly responsible for the illusion of the moon's axial rotation, which I shall endeavor to dispel by additional evidences.

With this object attention is called to Fig. 5 showing a system composed of eight balls M, which are carried on spokes S, radiating from a hub H, rotatable around a central axis O in bearings supposed to be frictionless. It is an arrangement similar to that before illustrated with the exception that the balls, instead of forming parts of the spokes, are supported in screw pivots s , which are normally loose but can be tightened so as to permit both free turning and rigid fixing as may be desired. To facilitate observation the spokes are provided with radial marks and the lower sides of the balls are shaded. Assume, first, that the drawing depicts the state of rest, the balls being rotatable without friction, and let an angular velocity $\omega = 2\pi n$ be imparted to the system in the clockwise direction as indicated by the long solid arrow. Viewing a ball as M, its successive positions 1, 2, 3-8 in space, and also relatively to the spoke, will be just as drawn, and it is evident from an inspection of the diagram that while moving with the angular velocity ω about O, in the clockwise direction, the ball turns, with respect to its axis, at the same angular velocity but in the opposition direction, that of the dotted arrow. The combined result of these two motions is a translatory movement of the ball such that all particles are animated with the same velocity V, which is that of its center of gravity. In this case, granted that there is absolutely no friction the

kinetic energy of each ball will be given by the product of $\frac{1}{2} M V^2$ not approximately, but with mathematical rigor. If now the pivots are screwed tight and the balls fixed rigidly to the spokes, this angular motion relatively to their axes becomes physically impossible and then it is found that the kinetic energy of each ball is increased, the increment being exactly the energy of rotation of the ball on its axis. This fact, which is borne out both by theory and experiment, is the foundation of the general notion that a gyrating body—in this instance ball M —presenting always the same face towards the center of motion, *actually* rotates upon its axis in the same sense, as indicated by the short full arrow. *But it does not tho to the eye it seems so.* The fallacy will become manifest on further inquiry.

To begin with, observe that when a mass, say the armature of an electric motor, rotating with the angular velocity ω , is reversed, its speed is $-\omega$ and the difference $\omega - (-\omega) = 2\omega$. Now, in fixing the ball to the spoke, the change of angular velocity is only ω ; therefore, an additional velocity ω would have to be imparted to it in order to cause a clockwise rotation of the ball on its axis in the true significance of the word. The kinetic energy would then be equal to the sum of the energies of the translatory and axial motions, not merely in the abstract mathematical meaning, but as a physical fact. I am well aware that, according to the prevailing opinion, when the ball is free on the pivots it does not turn on its axis at all and only rotates with the angular velocity of the frame when rigidly at-

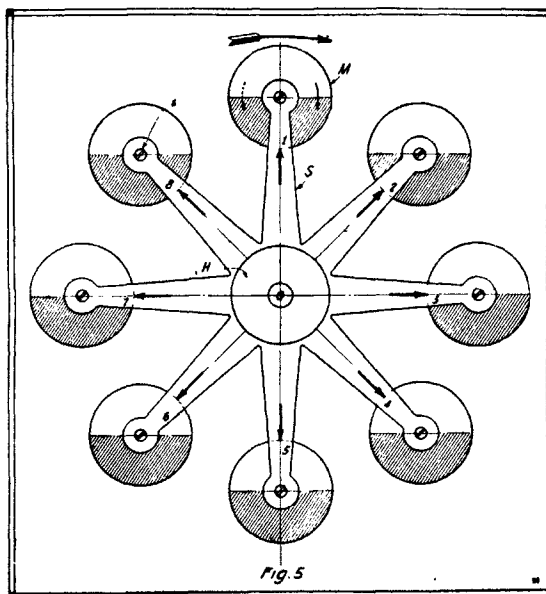

Fig. 5. This Diagram Represents a System Composed of 8 Balls M , Carried on Spokes S , and Rotating Around Center O . The Balls Are Freely Rotatable on Pivots Which Can Be Tightened. With This Model the Fallacy of the Moon's Rotation on Its Axis is Demonstrable.

those parts of the masses which are nearer to the center of motion, of some kinetic energy of translation while adding to the energy of those which are farther and, obviously, the gain was greater than the loss so that the effective velocity of each ball as a whole was increased. Only so have we augmented the kinetic energy of the system, not by causing axial rotation of the balls. The energy E of each of these is solely that of translatory movement with an effective velocity V_0 as above defined such that $E = \frac{1}{2} M V_0^2$. The axial rotations of the ball in either direction are but apparent; they have no reality whatever and call for no mechanical effort. It is merely when an extraneous force acts independently to turn the whirling body on its axis that energy comes into play. Incidentally it should be pointed out that in true axial rotation of a rigid and homogenous mass all symmetrically situated particles contribute equally to the momentum which is not the case here. That there exists not even the slightest tendency to such motion can, however, be readily established.

For this purpose I would refer to Fig. 6 showing a ball M of radius r , the center C of which is at a distance R from axis O and which is bisected by a tangential plane pp as indicated, the lower half sphere being shaded for distinction. The kinetic energy of the ball when whirled n times per second about O is according to the first form of expression $E = \frac{1}{2} M V_0^2 = \frac{1}{2} M (2\pi R n)^2$, M being the mass and R_0 the radius of gyration. But, as explained in connection with Fig. 4, we have also $E = \frac{1}{2} M V^2 + \frac{1}{2} I \cdot \omega^2$, $V = 2\pi R n$ being the velocity of the center of gravity C and I the moment of inertia of the ball,

about the parallel axis passing thru C and equal to $\frac{3}{8} M r^2$ so that $E = \frac{1}{2} M (2\pi R n)^2 + \frac{3}{8} M r^2 (2\pi n)^2$. Neither of these two expressions for E describes the actual state of the body but the first is certainly preferable conveying, as it does, the idea of a single motion instead of two, one of which moreover is devoid of existence. I shall first undertake to demonstrate that there is no torque or rotary effort about center C and that the kinetic energy of the supposed axial rotation of the ball is mathematically equal to zero. This makes it necessary to consider the two halves separated by the tangential plane pp wholly independent from one another. Let c_1 and c_2 be their centers of gravity, then $Cc_1 = Cc_2 = \frac{3}{8} r$. In order to ascertain the kinetic energy of the hemispheres we have to find their radii of gyration which can be done by determining the moments of inertia I_{c_1} and I_{c_2} about parallel axes passing thru c_1 and c_2 . Complex calculation will be avoided by remembering that the moment of inertia of either one of the half spheres about an axis thru C is $I_C = \frac{1}{2} \times \frac{3}{8} M r^2 = \frac{3}{16} M r^2$, and since $M = 2m$, $I_C = \frac{3}{8} m r^2$. This can be expressed in terms of the moments I_{c_1} and I_{c_2} ; namely, $I_C = I_{c_1} + m (\frac{3}{8} r)^2 = I_{c_2} + m (\frac{3}{8} r)^2$. Hence $I_{c_1} = I_{c_2} = I_C - m (\frac{3}{8} r)^2 = \frac{3}{8} m r^2 - 9/64 m r^2 = 83/320 m r^2$. Following the same rule the moments of inertia of the half spheres about the axis passing thru the center of motion O can be found. Designating the moments for the upper and lower halves of the ball, respectively, I_{O_1} and I_{O_2} we have $I_{O_1} = m (R + \frac{3}{8} r)^2 + I_{c_1} = m (R + \frac{3}{8} r)^2 + 83/320 m r^2$ and $I_{O_2} = m (R$

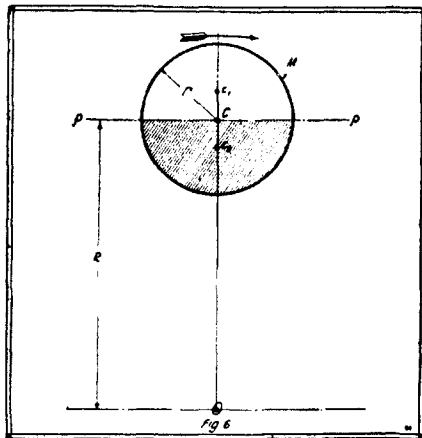

Fig. 6. Diagram Showing a Ball Having Mass M , of Radius r , Rotating About Center O , and Used in the Theoretical Analysis of the Moon's Motion.

tached to the same, but the truth will appear upon a closer examination of this kind of movement.

Let the system be rotated as first assumed and illustrated, the balls being perfectly free on the pivots, and imagine the latter to be gradually tightened to cause friction slowly reducing and finally preventing the slip. At the outset all particles of each ball have been moving with the speed of its center of gravity, but as the bearing resistance asserts itself more and more the translatory velocity of the particles nearer to the axis O will be diminishing, while that of the diametrically opposite ones will be increasing, until the maxima of these changes are attained when the balls are firmly held. In this operation we have thus deprived

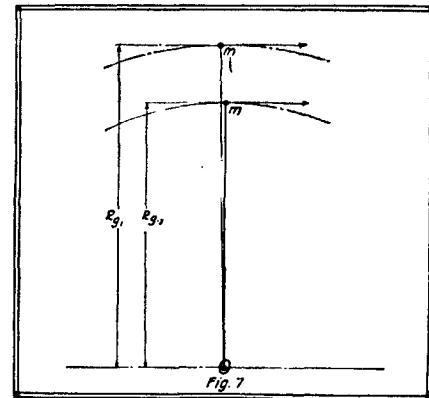

Fig. 7. Here Two Masses m - m , Are Considered as Condensed into Points Attached to Weightless Strings of Different Radii. If Both Strings Are Cut, and the Masses Considered as Joined, Then There Will Be No Rotation About the Common Center of Gravity.

$-\frac{3}{8} r)^2 + I_{c_2} = m (R - \frac{3}{8} r)^2 + 83/320 m r^2$. Thus for the upper half sphere the radius of gyration $R_{G_1} =$

$$\sqrt{\frac{I_{O_1}}{m}} = \sqrt{(R + \frac{3}{8} r)^2 + 83/320 r^2}$$

and for the lower one $R_{G_2} =$

$$\sqrt{\frac{I_{O_2}}{m}} = \sqrt{(R - \frac{3}{8} r)^2 + 83/320 r^2}$$

These are the distances from center O , at which the masses of the half spheres may be concentrated and then the algebraic sum of their energies—which are wholly translatory those of axial rotation being nil—will be exactly equal to the total kinetic energy of the ball as a unit. The

(Continued on page 156)

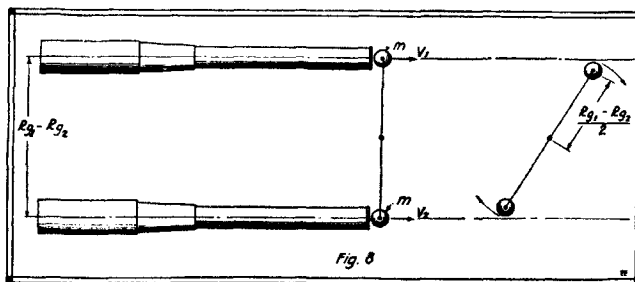
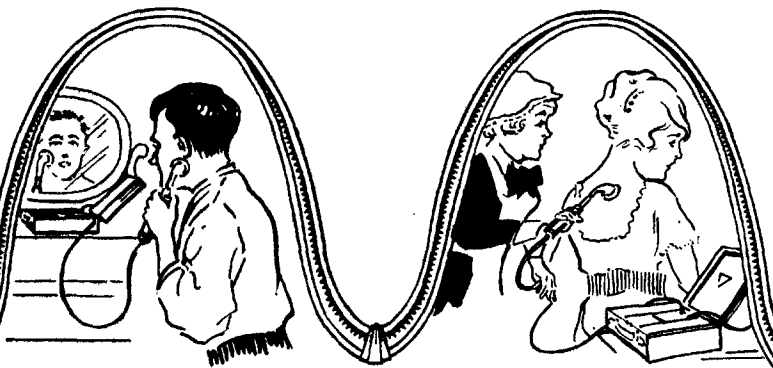

Fig. 8. To Make the Problem Shown in Fig. 7 Clear, Imagine Two Rifle Barrels Parallel to Each Other. If Two Balls M - M Are Fired Simultaneously, Joined by a Theoretical Bond, They Will Revolve About Their Common Center of Gravity, Proving That the Moon Possesses Only Kinetic Energy of Translation.



*For Perfect Health,
Strength, Unlimited Vitality &
Improved Personal Appearance*

The
**STERLING
HIGH FREQUENCY
VIOLET RAY**

CELEBRATED Physicians and leading Beauty Specialists receive fabulous fees for treating with the Violet Ray. You can have a health doctor and beauty specialist right in your own home for your daily service at an average cost of less than a penny stamp.

The Sterling High Frequency Violet Ray was specially designed for home use—fitted to work from the ordinary lamp socket—easy to manipulate—under control at all times—and contains within its covers the Services of a servant, a doctor of medicine, and a nerve and beauty specialist—all in one, ready for instant service.

The Sterling Violet Ray is invaluable in the treatment of diseases of the skin, mouth, throat and lungs, derangements of the liver, kidneys, stomach and intestines—soreness in muscles and joints—tired or "sick" brains or lack of "nerve tone." It strengthens heart action—cleanses the blood—brings the flush of youth to the skin—enlivens the hair—puts a "spring in your step" and creates a clear eye and brain.

Six hundred thousand vibrations per second saturate the entire body with electricity—fill the blood with oxygen

—eliminate waste, toxins, and poisons—
ALL enemies of youthfulness.

Sterling Violet Ray Generators are the creations of Mr. Anthony Longoria, our Chief Designing Engineer, whose long years of practical experience in the designing and operation of Violet Ray Generators entitle him to the commanding position he holds in their manufacture. They are based upon the original discoveries of Nikola Tesla, first given to the world in May, 1891, but have been developed to the highest state of perfection ever reached in this type of generators.

Book and Valuable Information Free

We want to send you our book and full particulars about the Sterling Violet Ray Machines. Read how you can treat innumerable diseases and ailments, improve your personal charm, add strength and vitality and help yourself in hundreds of ways. Just mail the coupon or drop a postal. Do it now, this minute, before you forget it.

THE STERLING ELECTRICAL CORPORATION
1278 West Third Street Cleveland Ohio



MAIL THIS COUPON FOR FREE BOOK

The Sterling Electrical Corporation, 1278 West 3rd St., Cleveland, Ohio.

Gentlemen:—

As per your offer in Electrical Experimenter, please mail me at once, free and postpaid, your book and full information about the Sterling Violet Ray Generators.

NAME
ADDRESS
CITY STATE

The Moon's Rotation
By Nikola Tesla
(Continued from page 133)

significance of this will be understood by reference to Fig. 7 in which the two masses, condensed into points, are represented as attached to independent weightless strings of lengths R_{e1} and R_{e2} which are purposely shown as displaced but should be imagined as coincident. It will be readily seen that if both strings are cut in the same instant the masses will fly off in tangents to their circular orbits, the angular movement becoming rectilinear without any transformation of energy occurring. Let us now inquire what will happen if the two masses are rigidly joined, the connection being assumed imponderable. Here we come to the real bug in the question under discussion. Evidently, so long as the whirling motion continues, and both the masses have precisely the same angular velocity, this connecting link will be of no effect whatever, not the slightest turning effort about the common center of gravity of the masses or tendency of equalization of energy between them will exist. The moment the strings are broken and they are thrown off they will begin to rotate but, as pointed out before, this motion neither adds to or detracts from the energy stored. The rotation is, however, not due to an exclusive virtue of angular motion, but to the fact that the tangential velocities of the masses or parts of the body thrown off are different.

To make this clear and to investigate the effects produced, imagine two rifle barrels, as shown in Fig. 8, placed parallel to each other with their axes separated by a distance $R_{e1} - R_{e2}$ and assume that two balls of same diameter, each having mass m , are discharged with muzzle velocities V_1 and V_2 , respectively equal to $2\pi n R_{e1}$ and $2\pi n R_{e2}$ as in the case just considered. If it be further supposed that at the instant of leaving the barrels the balls are joined by a rigid but weightless link they will rotate about their common center of gravity and in accordance with the statement in my previous article above mentioned, the rela-

$$\frac{V_1 - V_2}{2} = \pi n (R_{e1} - R_{e2})$$

tion will exist n being the number of revolutions per second. The equalization of the speeds and kinetic energies of the balls will be, under these circumstances, very rapid but in two heavenly bodies linked by gravitational attraction, the process might require ages. Now, this whirling movement is real and requires energy which, obviously, must be derived from that originally imparted and, consequently, must reduce the velocity of the balls in the direction of flight by an amount which can be easily calculated. At the moment of discharge the total kinetic energy was $E = \frac{1}{2} m V_1^2 + \frac{1}{2} m V_2^2$ which is evidently equal to $m V_a^2$, V_a being the effective velocity of the common center of gravity, from which follows that $V_a =$

$$\sqrt{\frac{V_1^2 + V_2^2}{2}}$$

The speed of revolution of the masses is, of course, $\frac{V_1 - V_2}{2}$ and the

rotational energy of both balls, which must be considered as points, is $e = m \left(\frac{V_1 - V_2}{2} \right)^2$

The kinetic energy of translation in the direction of flight is then $\frac{1}{2} m V_a^2 + \frac{1}{2} m V_a^2 = m \left(\frac{V_1 - V_2}{2} \right)^2 = m \left(\frac{V_1 + V_2}{2} \right)^2 = m V_a^2$, V_a being the speed of the

A-K TABLETS

FOR

All Pain

Headaches
Neuralgias
Colds and La Grippe

Women's Aches and Ills
Rheumatic and Sciatic Pains

Ask Your Druggist for A-K Tablets
(If he cannot supply you, write us)

Small Size **10c** Dozen Size **25c**

See Monogram **A-K** on the Genuine
The Antikemian Remedy Company, St. Louis, Mo.
Write for Free Samples



The Electric Safety razor makes shaving a pleasure. Blade vibrating 7,200 times a minute cuts the beard smoothly and without slightest pull or irritation—feels like a gentle massage. Can be used with or without electric current.

All users of the **Lek-Tro-Shav** speak well of it.

A barber says—"Have shaved for years and have never used any shaving device near its equal."
A home user says—"The most pleasing shave I've ever had in my life. Shaves my face closer than I used to shave, but there is no after irritation or ill effects as I usually get from another razor."

No. 1 Made for use from Light Socket.
No. 2 Made for use from Dry Battery.
Write for illustrated circular describing Lek-Tro-Shav Safety Razor fully.

VIBRATING ELECTRIC RAZOR CO.
Dept. 122, Omaha, Nebr.



FUN Noiseless Target Practice
Fit your .22 with a Maxim Silencer and get no end of fun this summer practicing in your back yard and on your vacation.

MAXIM SILENCER MAKES YOU A BETTER MARKSMAN

It eliminates recoil and all noise of the report, and steadies your aim. Direct from Dealer or Factory \$5.00. Write for Free Book of Stories.

MAXIM SILENCER CO.
89 Homestead Ave., Hartford, Conn.

A Cigarette With One Hand
Don't drop everything every time you want a smoke. Let

The **"HANDY"** Cigarette Case

Hand it to you. Pull the cover down, then up, and the cigarette is ready. Fits the pocket. Full Nickel-Plated, shipped Post-Paid on receipt of price.

50c
CASE MFG. CO., 241 W. 23rd St., New York

common center of gravity, so that $V_1 = V_2$ is the loss of velocity in the direction of flight owing to the rotation of the two mass points. If instead of these we would deal with the balls as they are, their rotational energy

$$e_r = e + i\omega^2 = m \left(\frac{V_1 + V_2}{2} \right)^2 + i(2\pi n)^2$$

i being the moment of inertia of each ball about its axis.

As will be seen, we arrive at precisely the same results whether the movement is rectilinear or in a circle. In both cases the total kinetic energy can be divided into two parts, respectively of the same numerical values, but there is an essential difference. In angular motion the axial rotation is nothing more than an abstract conception; in rectilinear movement it is a positive event.

Virtually all satellites rotate in like manner and the probability, that the acceleration or retardation of their axial motions—if they ever existed—should come to a stop precisely at a definite angular velocity, is infinitesimal while it is almost absolutely certain that all movement of this kind would ultimately cease. The most plausible view is that no true moon has ever rotated on its axis, for at the time of its birth there must have been some deformation and displacement of its center of gravity thru the attractive force of the mother planet so as to make its peculiar position in space, relative to the latter, in which it persists irrespective of distance, more or less stable. In explanation of this, suppose that one of the balls as M in Fig 5 is not of homogenous material and that it is similarly supported but on an axis passing thru its center of gravity instead of form. Then, no matter in what position the ball is fixed on the pivots, its kinetic energy and centrifugal pull will be the same. Nevertheless a directive tendency will exist as the two centers do not coincide and there is, consequently, no dynamic balance. When permitted to turn freely on the axis of gravity the body, of whatever shape it may be, will tend to place itself so that the line joining the two centers points to O and there may be two positions of stability but, generally, if the center of gravity is not greatly displaced, the heavier side will swing outwardly. Such condition may obtain in the moon if it had solidified before receding from the earth to great distance, when the

(Continued on page 160)

POPULAR ASTRONOMY

The Evolution of the Stars

(Continued from page 121)

Canopus, one of the giants of the universe. The transition of this type into the solar type stars of class G, to which our sun belongs, occurs when the group of iron lines known as group G begins to appear (see diagram I). The lines of calcium and hydrogen still remain more intense than any other lines in the spectrum, but many fine metallic lines now appear in ever-increasing intensity. The transition of this type into the advanced solar type K occurs when some of the metallic lines surpass the hydrogen lines in intensity. The group of iron lines has also greatly increased in intensity until it becomes one of the most conspicuous features of the K type stars. Stars of the solar type such as Capella and the sun are yellow, and stars of the advanced solar type, such as Arcturus and Aldebaran, are orange colored bordering on red. Their atmospheres are filled with dense metallic vapors. (See photos of solar and advanced solar type spectra.)
Class M is divided into giant and dwarf

Drake's Practical Mechanical Books

For Home Study

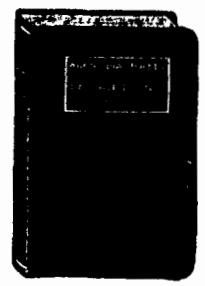

Pave the way for the big positions—the fat pay-envelopes. Written in non-technical language—easy to read—easy to understand. We will send any book post paid—keep them five days—if not entirely satisfied return the books and your money will be refunded in full. Order direct from this page. Use the coupon.

- ### Electrical Books
- Electric Motor Control Systems and Methods. Leatherette \$1.50
 - Electrical Tables and Engineering Data. Leatherette 1.50
 - Motion Picture Operation. Leatherette... 1.50
 - Alternating Current. Leatherette..... 1.50
 - Wiring Diagrams and Descriptions. Leatherette 1.50
 - Armature and Magnet Winding. Leatherette 1.50
 - Modern Electric Illumination. Leatherette 1.50
 - Modern Electrical Construction. Leatherette 1.50
 - Electricians' Operating and Testing Manual. Leatherette 1.50
 - Drake's Electrical Dictionary. Leatherette 1.50
 - Electric Motors, D and A. Leatherette... 1.50
 - Electrical Measurements and Meter Testing. Leatherette 1.50
 - Drake's Telephone Handbook. Leatherette 1.50

- ### Automobile Books
- Automobile Ignition. Leatherette, \$2.00
 - Brookes' Automobile Handbook. Leatherette \$2.00
 - Automobile Starting and Lighting. Leatherette .. \$1.50
 - Ford Motor Car, Truck and Tractor Attachments. Cloth, \$1.00
 - Ford Motor Car, Truck and Tractor Attachments. Leatherette .. \$1.50
 - Automobile Catechism and Repair Manual. Leatherette \$1.25
 - Gas and Oil Engine Handbook. Cloth... 1.00
 - Gas and Oil Engine Handbook. Leatherette 1.50

- ### Modern Language Courses
- French Without a Teacher, Spanish Without a Teacher, German Without a Teacher. By Professor Philip Schuyler Allen, University of Chicago. An entirely new home series of modern foreign languages. Simplest, easiest-to-master language method ever devised. French, Spanish or German. Pocket size. Each \$1.25

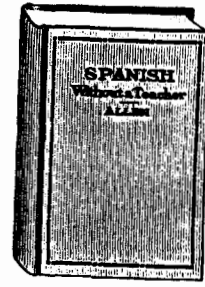

Mail the Coupon NOW
Order on our five day money back plan.
FREDERICK J. DRAKE & CO.,
1009 Michigan Ave., Chicago, Ill.
Enclosed find (\$.....), for which please send me prepaid the books checked in this adv. (or list attached). It is agreed that I may return same in 5 days if not entirely satisfied, and money will be refunded in full.
Name
Address

MY NEW BOOK

"Muscular Development"

will tell you how to get a wonderful muscular development like mine, perfect health, abundance of vitality and great strength as I have.

The results of my system are shown on my own person and that is recommendation enough. To give every one the opportunity to profit by what I have learned, I will mail my book, for a limited time only, on receipt of

10c Stamps or Coin

This wonderful book will help you. It is profusely illustrated and contains pictures of many of the world's strongest men whom I have trained. Send for it today. Right now, while it is on your mind.

EARLE E. LIEDERMAN Why not look as healthy and as strong as I am? EARLE LIEDERMAN, Dept. 209, 203 Broadway, N.Y.

RIGHT NOW—You Can Make Big Profits in BATTERY CHARGING

Owners of HB Chargers everywhere are making \$100 to \$400 Clear Profit every month. Business better than ever. YOU can do as well. Don't delay. Get out and get this business with sturdy, dependable HB Equipment.

THIS HB 500 WATT CHARGER WILL PAY YOU \$100 TO \$200 CLEAR PROFIT EACH MONTH No electrical knowledge required to install or operate. Recharges 7 1/2-volt batteries at once. Costs 15c to 16c each to recharge, customer pays 75c to \$1.00. Big, quick, clean profit—easy to make, no costly or expensive renewals. Steady service 24 hours a day. Economical to run, requires no attention, save occasional oiling.

\$25 Puts This Money-Maker in Your Garage on Money-Back Guarantee Balance in 3 monthly payments of \$20 each. Earnings really pay for machine. First \$20 initial payment check to this ad and send today for trial order. Sold under HB Absolute Money-Back Guarantee. Order NOW. Don't delay. Get busy! Get These Profitable HB CHARGERS TODAY! EARLE LIEDERMAN CO., Troy, Ohio Successful Manufacturers Since 1888



Mining Engineering For Your Profession

A wide and profitable field, not overcrowded, is open to forward-looking young men. The Michigan College of Mines (established 1886) offers a comprehensive four year course which can be completed in three years. Its breadth provides foundation for expert specialization in that field of engineering which most appeals to the student. All phases of technical knowledge and instruction relative to mine development and operation thoroughly presented by constructive methods. Practical experience is here combined with theoretical work in a rare way. College is located in center of one of the world's greatest copper mining districts. Close relations are constantly maintained with mines, mills, smelters, electrolytic and power plants which are practically a part of the College equipment and a factor of enormous value in instruction. "M. C. M. Men Make Good." For descriptive book address Administrative officer, Houghton, Mich.

Michigan College of Mines

Do You Want to Know HOW TO DEVELOP

Vitality, Energy, Endurance, Nerve Strength, Muscular Strength, Perfect Physique?



My FREE BOOKS. "The Why's of Exercise" and "The First and Last Laws of Physical Culture" tell you if you are weak or underdeveloped, how to grow strong; if strong, how to grow stronger. They explain how to develop the lungs and muscle, the strong heart and vigorous digestion—in short, how to improve health and strength internally as well as externally. SEND TODAY—NOW—for these FREE BOOKS. Enclose 4c in stamps to cover postage.

PROF. H. W. TITUS 56-58 Cooper Sq., Dept. 602, New York City

Advertisement for a mechanical device: Swing 4 in., 11 in. between centers, 17 in. total length. Shipping weight 15 lbs. Bed of lathe is machined. Workmanship first class. Equipped with wood turning chuck. Can be fitted with 3 in. face plate and drill chuck as special equipment. Order one today. Price \$5.00 cash with order. STUPPER MFG. CO., DEPT. C TOLEDO, OHIO

Advertisement for a stenography school: PAIN SHOW CARDS. I teach you personally, by mail, in a short time. Oldest and largest school. Big field, work interesting. You can EARN \$15 TO \$45 A WEEK. Phoenix, Minn., writes: "Did job after first lesson—now get \$15.00 a week." Detroit, Mich. writes: "Earned \$200.00 while taking course." Get literature, samples, guarantee all my classes. DETROIT SCHOOL OF LETTERING Established 1889. 605 D. C. of L. Bldg., DETROIT, MICH.

The Moon's Rotation

By Nikola Tesla

(Continued from page 157)

arrangement of the masses in its interior became subject to gravitational forces of its own, vastly greater than the terrestrial. It has been suggested that the planet is egg-shaped or ellipsoidal but the departure from spherical form must be inconsiderable. It may even be a perfect sphere with the centers of gravity and symmetry coinciding and still rotate as it does. Whatever be its origin and past history, the fact is, that at present all its parts have the same angular velocity as though it were rigidly connected with the earth. This state must endure forever unless forces from without the luna-terrestrial system bring about different conditions and thus the hope of the star-gazers that its other side may become visible some day must be indefinitely deferred.

A motion of this character, as I have shown, precludes the possibility of axial rotation. The easiest way to free ourselves from this illusion is to conceive the satellite subdivided into minute and entirely independent parts, as dust particles, which have different orbital, but rigorously the same angular, velocities. One must at once recognize that the kinetic energy of such an agglomeration is solely translational, there being absolutely no tendency to axial rotation. This makes it also perfectly clear why the moon, provided its distance does not greatly increase, must always turn the same face to us even without any inherent directive tendency nor so much as the slightest effort from the earth.

Referring to the librations of longitude, I do not see that they have any bearing on this question. In astronomical treatises the axial rotation of the moon is accepted as a material fact and it is thought that its angular velocity is constant while that of the orbital movement is not, this resulting in an apparent oscillation revealing more of its surface to our view. To a degree this may be true, but I hold that the mere change of orbital velocity, as will be evident from what has been stated before could not produce these phenomena, for no matter how fast or slow the gyration, the position of the body relative to the center of attraction remains the same. The real cause of these axial displacements is the changing distance of the moon from the earth owing to which the tangential components of velocity of its parts are varied. In apogee, when the planet recedes, the radial component of velocity decreases while the tangential increases but, as the decrement of the former is the same for all parts, this is more pronounced in the regions facing the earth than in those turned away from it, the consequence being an axial displacement exposing more of the eastern side. In perigee, on the contrary, the radial component increases and the effect is just the opposite with the result that more of the western side is seen. The moon actually swings on the axis passing thru its center of gravity on which it is supported like a ball on a string. The forces involved in these pendular movements are incomparably smaller than those required to effect changes in orbital velocity. If we estimate the radius of gyration of the satellite at 600 miles and its mean distance from the earth at 240,000 miles, then the energy necessary to rotate it once in a month would be only $\left(\frac{600}{240,000}\right)^2 = \frac{1}{160,000}$ of the kinetic energy of the orbital movement.

ZIP-ZIP Patented Sept. 8rd, 1918 The Greatest 50 Ct. Article on the Market. Shipped right from the factory the camera ready to receive your order. The Front made of beautiful metal; never break or wear out; adjustment simple and best workmanship. The rubberband is elastic and lasting, with plenty of pep and force. Zip-Zip, complete, only 50c. Zip-Zip and see the name Zip-Zip on the article you buy. Order from us or your nearest camera store in your city. Send stamps, coin or money order. AUTOMATIC RUBBER CO. COLUMBIA, S. C.

Telegraph Pictures BY ELECTRICITY Complete sets of two machines of this marvelous equipment at ridiculously low prices. Instructive, mystifying and useful. This picture of President Wilson was telegraphed by these machines. With transmit picture, message drawings and hand writing. Picture telegraphing is the coming science. Write today. J. LEISHMAN CO., Dept. T Opeia, Okla.

CLEARTONE PHONOGRAPHS \$4.00 to \$200.00 Retail Needles 45¢ per thousand in lots of 500,000 Motors \$1.35 to \$14.75 each. Vinyl Arms and Reproducers \$1.30 to \$5.75 per set. Main Springs 20¢ to 60¢ each. Records, Needles, Supplies Points and Parts at reasonable prices. Write for our 84 page catalogue, the only one of its kind in America, illustrating 33 different styles of Talking Machines and over 500 different Phonographs. LUCKY 13 PHONOGRAPH COMPANY Export Dept. 468 E. 12th St., N. Y., U.S.A.

SAVE 25% to 60% on slightly used GRAFLEX-KODAKS Cameras and Lenses of every description. Equal to new. Save money. Write now for Free Bargain Book and Catalog listing hundreds of money saving bargains at slightly used and new camera and supplies. All models sold on 10 days Free Trial. Money back if not satisfied. We have been in the photographic business over 40 years. Write now. CENTRAL CAMERA CO., Dept. 176 124 S. Wabash Ave., Chicago

UMAKEM Airplane Workchest, containing aircraft work table with built cutting board and length gauge, steel drill, steel hammer, Model Maker's steel square, screwdriver, sandpaper block, 10" scroll saw, together with finest quality red and brass wood, aluminum, silk, raw rubber, full set of blueprints, directions, and all fittings for building one 30" Blériot Model flying Monoplane. Price \$10.00. Other Umakem Outfits 50c to \$50. W. R. PRINE, Inc. No. 2 Umakem Building, 127 Fifth Avenue, New York

RAISE BELGIAN HARES 5% MAKE PROFITS easily and pleasantly made. We furnish stock and pay you \$2.00 a pair and express charge for all you raise. Contract and book. Write for terms in largest, by mail form. NATIONAL FOOD & FUR ASSOCIATION Dept. 24 MILWAUKEE, WIS.

EARN MONEY Stamping Names on Key Tops. \$50 either sex. Spare time. Some make \$100. Send 5c for Tag with your name on and instructions. Returned if required. Exp. Key Top Co., Cohoes, N. Y.

STAMMERER Send 10 cents for my remarkable book, "How to Stop Stammering." Kill the fear of stammering. Be education the key. The Hatfield Institute, 108 E. Dearborn St., Chicago, Ill.

TYPEWRITERS \$10 AND UP. ALL MAKES. SAVE \$25 TO \$80 on rebuilt at the factory by the well-known "Young Peoples" Sold for low cash—installment or rented. Rental applies on purchase price. Write for full details and guarantee. Free trial. YOUNG TYPEWRITER CO., Dept. 118, Chicago

BE A CPA ACCOUNTANCY The Highest Paid Profession taught thoroughly in a few months of home study by new system. Sold for low cash—installment or rented. Rental applies on purchase price. Write for full details and guarantee. FREE BOOK Dept. 307, 305 E. Mich. Ave., Chicago

158 Genuine Foreign Stamps—Mexican War Issues, Venezuela, Salvador and In-10c. 100 all diff. inc. 125; 200 all diff. 25¢. FINEST APPROVAL SHEETS 60¢ to 80¢. AGENTS WANTED. Big 75-page Lists FREE! We Buy Stamps. Exp. 10 years. W. E. MUSE & SON STAMP CO., Dept. 3, St. Louis, Mo.

Learn Watchwork, Jewelrywork and Engraving A fine trade commanding a good salary, and your services are always in demand. Address HOROLOGICAL Department, Bradley Institute, Peoria, Ill., for our latest catalog.

You benefit by mentioning the "Electrical Experimenter" when writing to advertisers.

Reconstruction

July, 1919, pp. 196-198

NIKOLA TESLA TELLS HOW WE MAY FLY EIGHT MILES HIGH AT 1,000 MILES AN HOUR - by Nikola Tesla

In an interview with Frederick M. Kerby.

As the inventor of the alternating current, the world is indebted to Mr. Tesla for the use of electricity carried long distances. He now discusses the probability that airplanes will rise to great heights and travel at speeds that seem incredible. This article is written, in part by Mr. Tesla himself. The rest is written from stenographic notes. It gives, very likely, a glimpse of the immediate future.

Sitting in his office on the twenty-fifth floor of the Woolworth Tower, Mr. J. Pierpont Jones, American business man, will one day glance at his watch and discover it is 3 o'clock in the afternoon.

"By George," he will say, buzzing for his secretary, "If I don't hurry I'll be late for that dinner engagement at the Savoy!" And as his secretary answers the buzzer:

"Charles, when does the next London bus leave?"

"Three-thirty, sir," says Charles. "You can make it if you hurry. The car is waiting."

And fifteen minutes later Mr. J. Pierpont Jones will emerge from the elevator on the aeronautic landing stage of lower Manhattan, climb into the hermetically sealed steel fuselage of the New York-London Limited, which will rise promptly at 3:30 p. m. At seven that night he will climb out of his compartment on the landing stage on the Thames Embankment, and descend to meet his friend for dinner.

The three-hour aeroplane trip from New York to London, flying above the storm level at eight miles above the earth's surface is the possibility of the immediate future.

This is not my own prediction. It is the result of sixteen pages of close calculations in higher mathematics made by Nikola Tesla, to test and check up other pages of intricate calculations made by Samuel D. Mott, charter member of the Aero Club of America.

Mr. Mott asserts that the three-hour trip to London from New York is a question of rising into rarefied air where the air pressure is only one-fifth what it is at the earth's surface, at which point the "altiplane", as he has named the flying machine of the future, may be expected to fly five times as fast as at the earth's surface. And if the speed of the aeroplane is increased not five times but only one-fifth, Mr. Mott says the trip will be made anyhow in the rarefied air eight miles above the earth's surface in not more than twelve hours running time.

And Nikola Tesla agrees that taking a plane to such an altitude must result in great increase in speed, although he does not wish, in the absence of exact knowledge of certain factors entering into the problem, to predict exact speeds.

Speaking before the Pan-American Aeronautic Convention at Atlantic City, Mr. Mott asserted that in order to avoid being weather-bound as were the aviators at Newfoundland, it will be necessary to construct planes that will rise above the storm limit.

"I submit," he said, "that waiting indefinitely for ideal weather conditions for long-distance flying over land or sea will not do for the demands of commerce. Therefore I would bring to your attention the possibilities from the airplane or

or hydroplane, to go into the stillness of nature above the weather.

What The Problem Is

"The problem is evidently one of equipment of our planes to function in rarefied air, and protection of navigators against its tenuity; likewise protection of their body warmth and comfort in extremes of temperature. How high we may go no one may know until tested. Personally I believe it possible to go fifteen or twenty miles aloft, if necessary. It is obviously a matter of equipment plus climbing ability of aircraft designed for the purpose.

"What is the object of high flying? Daily experience shows us that high speed and density are incompatible. We know that we must furnish aircraft with four times the power to go twice as fast, and the marine engineer knows that he must furnish eight times the power to go twice as fast. In other words, from the ultimate height of the air to the earth's core pressure is progressive. Thirty-three feet below the ocean's surface the pressure doubles. For every 1,000 feet ascent the pressure diminishes roughly one-half pound per square inch. The pressure two miles high is 9.8 pounds per square inch; at one mile high, 10.88; at three-quarters of a mile, 12.06; one-half mile, 13.33; one-quarter mile, 14.2, and at sea level, 14.7 pounds, or, in round numbers, 15 pounds per square inch.

"The unknown factor in the high altitude problem is this: Will an altiplane in one-fifth density (eight miles high), with equal push, go five times faster or one-fifth faster? The rest is a matter of simple equipment and good construction. In either case the gain is substantial. If the former were true a voyage between New York and London can be made in about three hours by going eight miles high. If the latter is true the same voyage can be made in about twelve hours running time, assuming a surface speed of 200 miles an hour, which is practically a question of power.

"To my mind it is plain that the high altitudes will be determining factors in long distance flying. Greater speed, greater distance, more comfort and less danger because when we double the time to do a risky thing we double the risk incurred; less gasoline, less weight and expense, for if environment permits us to go 100 miles with twice the fuel we formerly used to go twenty-five miles our economic gain is obviously 100 per cent, because we may then go 100 miles with the amount of fuel we formerly consumed to go fifty miles."

That aerial navigation at higher altitudes will undoubtedly result in great increase of speed is also the opinion of Nikola Tesla, to whom I took Mr. Mott's conclusions in order to get the opinion of this man who has made a life-time study of the air as a medium for the transmission of electrical energy.

"In the propulsion of aerial vessels problems are involved entirely different from those presented in the navigation of the water," said Tesla. "The atmosphere may be likened to a vast ocean, but if one imagines a submarine vessel constructed like an aeroplane one immediately realizes how inefficient it would be. The energy used in propelling a body through a medium of any kind is wasted in three different ways; first, by skin friction; second, wave making; third, production of eddies. On general principles, however, the resistance can be divided into two parts: one which is due to the friction of the medium and the other to its stickiness, or viscosity, as it is termed. The first is proportionate to the density; the second to this peculiar property of the fluid.

"Everybody will readily understand that the denser the medium the harder it is to push a body through it, but it might not be clear to every person what this other resistance - this viscosity - means. This will be understood if we compare, for instance, water and oil. The latter is lighter, but much more sticky, so that it is a greater obstacle to propulsion than water. Air is a very viscous substance

and that part of resistance which is due to this quality is considerable. We must take this latter resistance into account in calculating how fast an aeroplane could fly in the upper reaches of the air.

"Now, the idea is to fly at a great height where the air is rarefied, and therefore much less power is required to propel the machine through it. If we take the pressure at sea-level at 14.7 pounds and the temperature at 15 degrees centigrade, then, without introducing several corrections that would make for greater accuracy, the pressures at different heights are about as follows: At 1,000 feet above sea-level, 14.178 lbs.; at one-mile, 12.1457 lbs.; at two miles, 10.035 lbs.; at eight miles, 3.1926 lbs.; at fifteen miles, 0.8392 lbs. and at twenty miles, 0.323 lbs.

Condition Eight Miles Up

"According to these figures that I have worked out, at a height of eight miles the density of the air is 0.2172 or about 22-100th of that at sea level; at fifteen miles it is 0.057, and at twenty miles only 0.0219, or nearly 22-1000th of that at sea-level.

"Let us suppose then that an aeroplane rises to a height of eight miles where the pressure of the air will be only 3.1926 lbs., or, in other words, the density 0.2172 of that at sea-level. Since, as pointed out, the purely frictional resistance is proportionate to the density of the air, it is obvious that, if there were no other resistance to overcome, only about 22 per cent of power or roughly one-fifth, would be required to propel the vessel at that height, so that extremely high speed, as Mr. Mott points out, would be obtainable.

"And though the other resistance, which is due to the stickiness of the medium, will not be diminished at the same ratio, and therefore the gain will not be strictly in proportion to the decrease of density of the air, nevertheless, the total resistance will be reduced, if not to 22 per cent, perhaps to 30 per cent, so that there will be a great excess of power available for more rapid flight.

"Even allowing for the decreased thrust of the propeller due to the thinness of the air, which cannot be overcome by driving the screw faster, there still will be the very considerable gain and the aircraft will be propelled at a higher speed.

"Of course many incertitudes still exist in the theoretical treatment of a question like this, as there are a number of factors which affect the result and in regard to which we have not yet complete information.

At An Altitude of Twenty Miles

"I doubt that it will be possible to rise as high as fifteen or twenty miles, which is the opinion expressed by Mr. Mott. At the height of twenty miles there is only about 7 per cent of oxygen in the air instead of 21 per cent which is present close to the ground, and there would be great trouble in securing the oxygen supply for the combustion of the fuel, not to speak of other limitations.

"However, at a height of eight miles the decrease of oxygen can be overcome for both engine and aviator. Of course provision would have to be made for supplying the aviator and passengers with oxygen. In all probability they would have to be entirely enclosed just as a diver is enclosed. Our highest mountains are five miles and the rarefication of the air makes climbing them difficult. About five miles provision would certainly have to be made for supplying the aviator. If he were not enclosed the decrease of pressure due to the thinner air would result disastrously. The human mechanism is adjusted to a pressure of nearly 15 pounds per square inch; and if that pressure is reduced to about three pounds, as it would be at an altitude of eight miles, the aviator's ear drums would burst, and even the

blood would be forced through the pores and would ooze out of the body.

Tesla explained that the effect would be the same as that of bringing a deep-sea fish, accustomed to live a mile below the surface, to the surface of the water. The fish simply explodes, for lack of the pressure which its body is built to withstand.

With proper protection of the aviator and an artificial supply of oxygen Tesla believes that flights at the eight-mile altitude are quite possible.

"Then there will be great progress with the lighter than air machine and we may soon expect the advent of a dirigible of the Zeppelin type as a common vehicle for travel. Contrary to the general belief, such a vessel can be propelled more rapidly than an airplane and it will be, on the whole, much safer. Furthermore it will give to the passengers the comforts that are necessary in order to make this form of travel popular. Of course in the practical use of these monstrous structures, formidable obstacles will be encountered. They are susceptible to damage by storms, and I believe also from certain danger from lightning, which will not be obviated by the use of helium gas. But I expect to see these difficulties overcome.

The dirigible, supplied with sufficient power, need not fear the storm; it can rise above it, or go around it. The only danger from storm in any case lies in being blown from the course, for while the ship is moving with the storm it is in no danger, since it travels at the same speed as the wind, and the passengers would be in absolutely quiet air, so that a candle might be lighted on deck. Methods of docking and housing the big ships must be devised, but several have been proposed that reduce the danger of landing by making it unnecessary for the ship to come to earth. "

But the revolutionizing influence on aircraft of the future Mr. Tesla believes to lie in the possibility of transmitting power to them through the air.

"For years," he said, " I have advocated my system of wireless transmission of power which is now perfectly practicable and I am looking confidently to its adoption and further development. In the system I have developed, distance is of absolutely no consequence. That is to say, a Zeppelin vessel would receive the same power whether it was 12,000 miles away or immediately above the power plant. The application of wireless power for aerial propulsion will do away with a great deal of complication and waste, and it is difficult to imagine that a more perfect means will ever be found to transport human beings to great distances economically. The power supply is virtually unlimited, as any number of power plants can be operated together, supplying energy to airships just as trains running on tracks are now supplied with electrical energy through rails or wires.

"The transmission of power by wireless will do away with the present necessity for carrying fuel on the airplane or airship. The motors of the plane or airship will be energized by this transmitted power, and there will be no such thing as a limitation on their radius of action, since they can pick up power at any point on the globe.

The advance of science to this point, however, is attended with terrible risks for the world. We are facing a condition that is positively appalling if we ever permit warfare to invade the earth again. For up to the present war the main destructive force was provided by guns which are limited by the size of the projectile and the distance it can be thrown. *In the future nations will fight each other thousands of miles apart. No soldier will see his enemy. In fact future wars will not be conducted by men directly but by the forces which if let loose may well destroy civilization completely.* If war comes again, I look for the extensive use of self-propelled air vehicles carrying enormous charges of explosive which will be sent from any point to another to do their destructive work, with no human being

aboard to guide them. The distance to which they can be sent is practically unlimited and the amount of explosive they can carry is likewise practically unlimited. It is practicable to send such an air vessel say to a distance of four or five thousand miles and so control its course either gyroscopically or electrically that it will land at the exact spot where it is intended to have it land, within a few feet, and its cargo of explosive can there be detonated.

"This cannot be done by means of the present wireless plants, but with a proper plant it can be done, and we have here the appalling prospect of a war between nations at a distance of thousands of miles, with weapons so destructive and demoralizing that the world could not endure them. That is why there must be no more war."

Can Radio Ignite Balloons?

AS a result of the newest theory, that powerful induced currents emanating from the Naval Radio Station in Chicago produced the spark that ignited the Goodyear dirigible airship which plunged in flames thru the roof of a bank building in that city, resulting in death for thirteen persons and injury to

The Opinions of Nikola Tesla and Other Radio Experts

Station. The building thru the skylight of which the blazing dirigible fell was the Illinois Trust and Savings Bank.

head of a large engineering corporation and foreman of the coroner's jury of technical men, said experts had suggested the radio theory to him.

Col. J. C. Morrow, chief air officer of the central department of the army, the principal witness at the inquest, was a passenger in the dirigible on a trip preceding

LEROY'S RADIO APPARATUS FOR DEMONSTRATING IGNITION BY WIRELESS.

HEAVY WIRE LOOP
TRANSMITTING LOOP
SPARK GAP
15-20 SPARK COIL
MERCURY INTERRUPTER
DISTANCE OF SEVERAL YARDS
AIR TIGHT GLASS VESSEL
MICROMETER SPARK GAP
GLASS PLATE AND TIN FOIL CONDENSER
ADJUSTABLE ON WHICH SUBSTANCES TO BE IGNITED ARE PLACED

SPARKS WILL OCCUR IN BREAKS OR LOOSE WIRE JOINTS IN BALING WIRE

HERTZ RESONATOR

CURRENT INDUCED IN SEVERAL BALES, DISCHARGING FROM ONE BALE TO ANOTHER.

WIRE OR METAL HOOPS IN CLOSE PROXIMITY TO EACH OTHER MAY CAUSE SPARKS TO OCCUR

LABORATORY TEST WITH RADIO FREQUENCY CURRENTS SHOW THAT METAL OBJECTS DON'T HAVE TO BE COILED - BUT CAN BE STRAIGHT, AND SPARKS WILL JUMP AS SHOWN BETWEEN ADJACENT METAL RODS OR WIRES DUE TO UNIPOLAR INDUCTION

NON RIGID GAS DIRIGIBLE
METAL WIRE

NOTE CURRENTS INDUCED BY RADIO WAVES IN METAL GIRDER FRAMING OF DIRIGIBLE A SPARK MAY OCCUR AT A LOOSE JOINT, BOLT OR RIVET, BURNING THE BAG FABRIC AND IGNITING THE GAS. LABORATORY TESTS WITH A SMALL TESLA COIL AND WIRE CAGES, ET CETERA, PROOVE THIS.

HOW RADIO INDUCED CURRENTS MAY BE SET UP IN METAL GONDOLAS GUY WIRES ETC. AND CAUSE SPARKS TO JUMP

INSULATORS
TO BREAK UP "RESONANCE"
AND PREVENT THE BALLOON WIRES FROM BECOMING HIGHLY CHARGED THEY SHOULD BE BROKEN UP INTO SHORT LENGTHS BY INSULATORS

100ft

INDUCTIVE LOOP, CONDENSER AND LAMPS CONNECTED THUS

NIKOLA TESLA'S HIGH FREQUENCY TRANSMITTER

LAMPS → LOOP CONDENSERS

— HOW RADIO MAY INDUCE CURRENTS IN AIRSHIPS —

Copyright, 1919, by E. P. Co.

Herewith Are Shown Some of the Plausible Reasons Why the Recent Chicago "Blimp" Disaster Might Have Been Caused By a Spark Induced By An Adjacent Radio Station. The Photo in the Lower Right-hand Corner Shows Three Incandescent Lamps Lighted to Full Candlepower, At a Distance of 100 Feet from Dr. Nikola Tesla's Colorado High Frequency Power Plant. The Oscillator Was Worked At Less Than Five Per Cent of its Total Capacity.

twenty-seven others, naval communication officers will aid the authorities in fixing responsibility for the disaster. It was ascertained that technical experts had suggested this theory, because the big ship sailed over or near the Transportation building, from the roof of which are projected the antennae of the Naval Radio

Lieut. F. S. Mason, of the Great Lakes Naval Training Station, district communication service officer, while refraining from agreeing with the theory, said he would cooperate with the investigating officials. Pilot John Boettner, of the ill-fated dirigible, said he had not been aware of the location of the naval radio station. H. M. Byllesby,

the fatal one. At that time he said the ship was in safe condition. The pilot he considered competent. He thought the possibility of sparks from the exhaust igniting the gas bag very remote, but said he had not formed an opinion as to the cause of the accident.

(Continued on page 591)

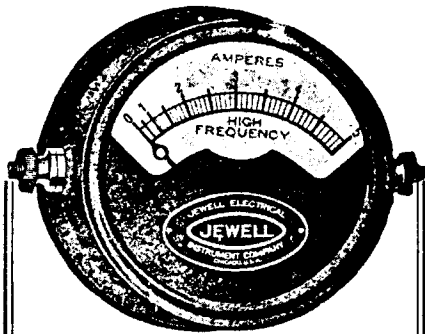

RADIO FREQUENCY AMMETER

4 inch Face

0 to 3, 0 to 5 or 0 to 10 Amperes.
Specify Reading Required.

\$11.00 Net

The Jewell Electrical Instrument Co. is prepared to fill the instrument needs of the amateur experimenter in radio and general electrical work, as well as those who desire more precise and accurate measurements of electrical quantities.

We show above our high frequency ammeter, of the thermo couple type, especially desirable for medium sized installations.

For receiving panels, we are supplying small D. C. instruments for plate voltage and filament current, at a very reasonable price.

Write for our special radio instrument bulletin.

JEWELL ELECTRICAL INSTRUMENT CO.

1640 Walnut St. Chicago

Audion Control Panel

Type P-100
—combining in a single compact set the Peerless De Forest Audion Detector, oscillator and audion amplifier, built for the audion as only the makers of the audion can build it. No other set like it has ever been built to sell for less than \$150.00. Our Price without the bulb \$65.00. Descriptions of lower priced models sent on application.

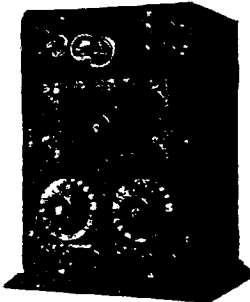

priced models sent on application.

The latest in Amplifier design sufficient to give amplifications up to 20,000 times. Panel quickly removable making all parts accessible, and the replacing of the new type on block "B" batteries but a moment's work. Workmanship of the highest grade. Price without the bulbs \$69.50.

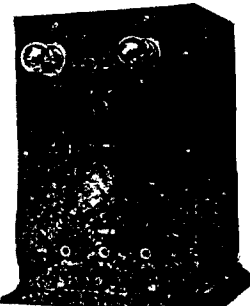

DeForest Radio Telephone & Telegraph Co.

1415 Sedgwick Avenue
New York City

Can Radio Ignite Balloons?

(Continued from page 516)

WHAT NIKOLA TESLA SAYS

Probably no other living electrician could be found today who can more authoritatively state just what effect can be produced at a distance by radio currents, than Dr. Nikola Tesla. He has produced and measured the greatest electrical discharges ever developed by man—sparks 70 to 100 feet in length, which manifested their influence 12 miles and more distant. In a special interview with the ELECTRICAL EXPERIMENTER representative, Dr. Tesla said in regard to the present blimp disaster:

"Referring to electrical or radio wave action at a distance, I know from experience that if proper precautions are not taken, fires of all kinds and explosions can be produced by wireless transmitters. In my experiments in Colorado, when the plant was powerfully excited, the lightning arresters for *twelve miles around* were bridged with continuous arcs, much stronger and more persistent than those which ordinarily took place during an electric storm. I have excited loops (coil aeriels) and lighted incandescent lamps at a considerable distance from the laboratory without even using more than five or ten per cent of the capacity of the transmitter. When the oscillator was excited to about 4,000,000 volts and an incandescent lamp was held in the hand about *fifty or sixty feet from the laboratory*, the filament was often broken by the vibration set up, giving some idea of the magnitude of the electromotive forces generated in the space. The accompanying illustration shows one of my experiments in which I lighted several lamps at a distance of 100 feet from the laboratory, purely by wireless energy. Such induced currents might easily fire a gas balloon under the proper conditions. When the large transmitter coil, 51 feet in diameter, which I had in the center of the laboratory, was powerfully energized, butterflies were carried around in a circle as in a hurricane and could not get out, no matter how they tried. I was unable to satisfactorily explain the gyrations in the circle, altho I can well understand that the charged coil might, by repulsion, keep them in the center. Perhaps the most remarkable of all the observations was the production of sparks in the sand when one walked at some distance from the building. At night a continuous stream of tiny sparks could be seen between the heels and the earth and between the grains of sand. Another most curious effect was the action on horses, which shows how very sensitive they are to electric shock. When I operated with undamped waves, the oscillator being perfectly silent (no streamers whatever), a horse at a distance of perhaps *one-half a mile*, would become scared and gallop away the instant the switch was thrown on. I suppose the capacity of the body was sufficiently great to derive a rather strong current thru the legs which would frighten the animal. When using damped waves the roar was so strong that it could be plainly heard ten miles away and despite all precautions, such as using cotton in the ears, one would get a singular sensation in the head as if something was bursting, similar to that I observed with Röntgen Rays in 1896 or '97, when I was operating with a powerful apparatus designed for their production.

"In my experiments in New York in the laboratories at 35 South Fifth Avenue and at Houston Street, I have exhibited to thousands of people effects of loops or coil antennae. In one experiment, for instance, I would tune a coil about 30 inches in diameter with which I would collect at

Fit Yourself for the Big Job

Don't hesitate any longer. There is a greater demand for trained men now than ever before—greater opportunities—bigger pay—more rapid advancement. It's training that counts now—accurate knowledge—a complete grasp of your trade.

Drake's Practical Mechanical Books

For Home Study

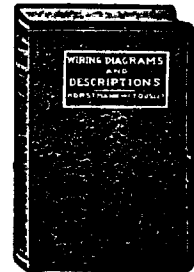

Pave the way to the fat pay envelope. Written in non-technical language that any man can grasp. Send the price of any book listed below. We will send the books post-paid—you keep them five days—if not entirely satisfied return the books and your money will be refunded in full. Order direct from this page. Use the Coupon.

Electrical Books

- Electric Motor Control Systems and Methods. Leatherette. \$1.50
- Electrical Tables and Engineering Data. Leatherette. 1.50
- Motor on Picture Operation. Leatherette. 1.50
- Alternating Current. Leatherette. 1.50
- Wiring Diagrams and Descriptions. Leatherette. 1.50
- Armature and Magnet Winding. Leatherette. 1.50
- Modern Electric Illumination. Leatherette 1.50
- Modern Electrical Construction. Leatherette. 1.50
- Electricians' Operating and Testing Manual. Leatherette. 1.50
- Drake's Electrical Dictionary. Leatherette 1.50
- Electric Meters, D and A. Leatherette. 1.50
- Electrical Measurements and Motor Testing. Leatherette. 1.50
- Drake's Telephone Handbook. Leatherette 1.50

Automobile Books

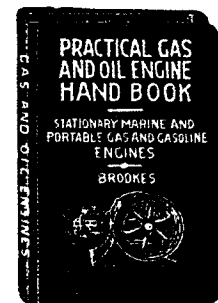

- Automobile Ignition. Leatherette. \$2.00.
- Brookes' Automobile Handbook. Leatherette. \$2.00
- Automobile Starting and Lighting. Leatherette. \$1.50
- Ford Motor Car, Truck and Tractor Attachments. Cloth. \$1.00
- Ford Motor Car, Truck and Tractor Attachments. Leatherette. \$1.50
- Automobile Catechism and Repair Manual. Leatherette. \$1.25
- Gas and Oil Engine Handbook. Cloth. 1.00
- Gas and Oil Engine Handbook. Leatherette. 1.50

Manual. Leatherette. \$1.25

Modern Language Courses

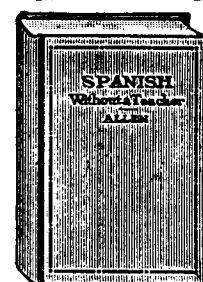

FRENCH SPANISH GERMAN Without a Teacher
By Professor Philip Schuyler Allen, University of Chicago. An entirely new home series of modern foreign languages. Simplest, easiest - to - master language method ever devised. French, Spanish or German. Pocket size.

Each\$1.25
Drake books are for sale at all leading book stores. Do not accept substitutes.

Mail the Coupon NOW

Order on our five day money back plan.

FREDERICK J. DRAKE & CO.,

1009 Michigan Ave., Chicago, Ill.

Enclosed find (\$.....), for which please send me prepaid the books checked in this adv. (or list attached). It is agreed that I may return same in 5 days if not entirely satisfied, and money will be refunded in full.

Name.....

Address.....

DEPENDABLE KNAPP ELECTRICAL SPECIALTIES

Motors and Electrical Specialties Are Best

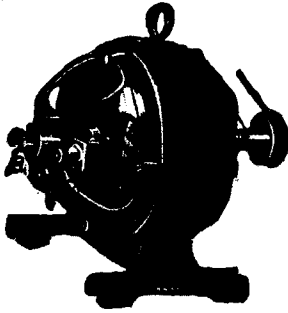

KNAPP DYNAMO MOTOR

Will electroplate, charge storage batteries, run lamps, motors, train of cars, induction coils,—in fact, the number of experiments it can be used for is unlimited. Runs on 4 to 8 Volts or can be connected to run on 110 Volts through a transformer.

Price, Complete, \$8.00

Order to-day. Or your dealer can secure them for you. **DESCRIPTIVE CIRCULAR and CATALOG of celebrated KNAPP MOTORS and Electrical Specialties from 10c up mailed FREE on request.**

KNAPP ELECTRIC & NOVELTY CO., 523 West 51st Street, New York City

Knapp Goods have stood the test for 29 years. No detail in construction has been spared to make them the best that money can buy. The complete Knapp line includes Toy and Power Motors, Generators and Dynamos, Specialties and Novelties that amuse and instruct. Fans, Rheostats, Compasses, etc. And Knapp prices are always lowest. Always insist on Knapp Goods.

KNAPP "LEADER"

An efficient and reliable motor that greatly resembles the big motors of real power plants. Drives from either pulley. Two speeds and reverse. A motor that you will be proud to own and one that will give you unlimited service.

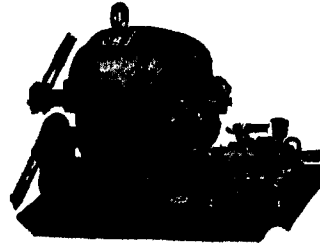

Price, Complete, \$4.00

ARE YOU GETTING THE MOST OUT OF YOUR RECEIVER?

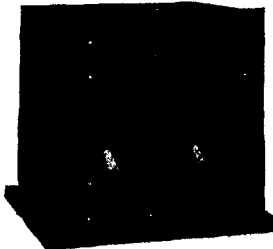

The ether is full of signals these days, some easy to hear and some inaudible. Inaudible because the proper apparatus is not being used.

It is to make those inaudible signals audible that the Grebe RORB two-stage audio-frequency amplifier has been designed. Here is a properly

balanced two-stage amplifier, which gets the most out of available vacuum tubes without distortion. A telephone cam switch with auxiliary contactors accomplishes the change from the "off" position to either one or two stages without necessitating any other manipulations. The filaments, as well as the stage circuits, are controlled by this cam switch. This is a feature not found in other amplifiers available at present. Send for bulletin R-108.

TYPE RORB, TWO STAGE AMPLIFIER, PRICE, \$45.00

A. H. GREBE & CO.

RICHMOND HILL

NEW YORK

Boys! You Can Make Your Own Electrical Apparatus with the aid of these wonderful books

Home-made Electrical Apparatus

By A. M. Powell

Three wonderful big books, chock full of just the sort of information you have been looking for and at a price within reach of your pocket book. Each volume is printed on heavy paper, contains 75 pages and over 60 illustrations, complete working drawings for making every sort of electrical apparatus. Written so you can understand them. The price is only 30 cents per copy—practically the cost of publication. See partial table of contents below and order now. The supply is limited.

Vol. I contains working drawings and directions for making all sorts of Static Machines, Static Apparatus, Home-made Batteries, Storage Cells, Transformers, Rectifiers, etc.

Vol. II contains working drawings and directions for all sorts of Voltmeters, Ammeters, Galvanometers, Switches, Rheostats, Telegraph Keys, Sounders, Telephones, Shocking Coils, Spark Experiment, etc., etc.

Vol. III contains working drawings and directions for making all sorts of Dynamos, Motors, Electric Engines, Miniature Lighting Plants, Wireless Telegraph Apparatus, Tesla Coils, Wireless Telephone, Electroplating, Experiments, etc., etc.

Any one of these wonderful books will be sent to you *postpaid* for 30 cents.

COLE & MORGAN, Inc., Publishers and Booksellers

P. O. Box 473, C. H. Sta.,

New York City



Arnold

Loose Couplers

Combination Loose Coupler Parts and accessories.

Send 3c stamp for literature which is sure to interest you.

J. F. ARNOLD

2082 Lexington Av. N.Y.
Established 1910

ADVANCED EXPERIMENTERS

Our specialty is to serve you. We build high-grade apparatus or models to specifications, furnish standard apparatus, parts, materials and supplies and do special machine work. Tell us your needs.

JUNIOR EXPERIMENTERS

We are getting out a line of electrical and wireless apparatus especially for you. Each article is well made, practical and instructive as well as inexpensive. Cat. E and code sent for 3c stamp.

THE WILCOX LABORATORIES, Lansing, Mich.

any place in a large hall, nearly three-quarters of a horsepower, lighting incandescent lamps, producing long discharges, streamers, etc. One of my exhibits, which was particularly appreciated, was a coil carried on the head which, when resonantly excited, would develop streamers several feet long.

"As regards that deplorable accident to the blimp in Chicago, of course a powerful wireless plant is capable of setting up, at a few hundred feet distance, electro-motive forces of such magnitude that if there is even moderate rise thru resonance, long sparks may result. In Colorado I drew 1-inch sparks between my body and an iron pipe buried in the ground about 100 feet from the laboratory. I think it perfectly practicable to produce an explosion by wireless designedly at a considerable distance from a wireless transmitter, and I look upon the accident as very likely having been due to some such cause. By taking proper precautions, however, it is possible to entirely eliminate this danger and I have devoted much thought to the subject, having early recognized the peril to such bags filled with hydrogen. According to my ideas, the accident is not so much chargeable to the plant as to the neglect of proper precautions on the aerial vessel itself. Such a vessel has a considerable span and the guy wires, gondola and other metallic parts constitute a considerable capacity, so that an appreciable amount of energy can be deprived from a wireless plant at a great distance, as it is well shown in the ease with which messages are transmitted to, and received from, aerial vessels.

"Why do the naval and other authorities allow such forms of aircraft to use an explosive gas like hydrogen? A short time ago the press was filled with the wondrous stories of how the U. S. Government experts had perfected the manufacture of the new and non-inflammable balloon gas—helium, to such an extent that it was very cheap and readily obtainable in quantities. Funny, how these "new" inventions require so long a time to reach the public and those who need them. Helium, extracted from illuminating gas, is not new or wonderful at all. My friend, Sir James Dewar, showed me experiments with it over 20 years ago."

How radio waves, even at distances of several miles, can cause sparks to occur among bales of cotton, baled with wire hoops, etc., is shown in one of the accompanying illustrations. The cotton bale wires have currents induced in them every time a radio message is sent from the ship or in its vicinity. This induced current is practically never strong enough to heat up the wire, but should one of these wires break and form a spark gap, then very often the induced current will cause a spark to jump the gap. That is enough to start a fire. Where wired bales are packed close together in the hold of a steamer, in trains, or warehouses, here also radio waves are liable to cause fairly strong electrical oscillations to be set up by resonance in adjacent loops on the bales, as the diagram shows. Result, a spark occurs, and another fire of "unknown origin" has started.

M. George A. Leroy, a French chemist, in his municipal laboratory at Rouen, France, very ably demonstrated that wireless waves could without doubt cause fires at a distance. His apparatus is shown schematically herewith.

Mr. Leroy's apparatus has been christened by him the "Igniting Resonator." The apparatus he used consists of a glass hull having four apertures; one at either side and one at the top and bottom, respectively. The substance to be tested with this igniter resonator can be placed in the airtight glass compartment and the two electrodes very accurately adjusted by micrometer screws fitted to them. The transmitter comprises a spark coil giving a 15-to-20-

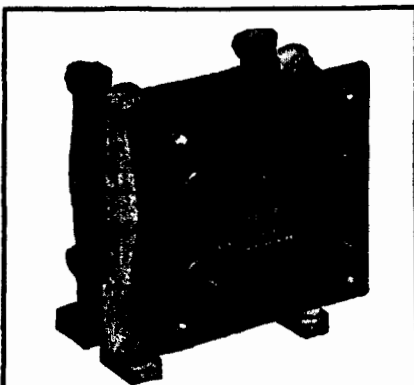

BUY THE BEST

The Audion or V T Detector has been vastly improved in recent years. To keep pace with this improvement we have developed the Amplifying Transformer to a degree hitherto unapproached.

These instruments are carefully made of the best materials obtainable.

Ratio of Turns 4 to 1.
Ratio of Amplification about 25 to 1 per step.

Peak Amplification Approx. 1000 Cycles.
Price \$10.00 Mounted, \$7.50 Unmounted.

If your Dealer cannot Supply you, immediate delivery can be made direct from the factory.

ACME APPARATUS CO.
28 WINDSOR ST., CAMBRIDGE, MASS.

NEW catalog just off the press. Seventy-six pages of new apparatus for the Radio Experimenter. Send 4c for this complete catalog.

**Haller, Cunningham
Electric Co.,**

428 Market Street,
San Francisco, Cal.

Get Our Prices

on the Wireless Apparatus
you need, before buying.

We handle new and second hand instruments on which we can save you money.

All Second Hand Instruments guaranteed to be in perfect working order.

WHAT DO U NEED?

Send us your list now

Radio Equipment Co.

630X Washington St. Boston, Mass.

NATIONAL TRADE DENTAL SCHOOL

808 S. Wabash Ave., Chicago, Ill.

LEARN MECHANICAL DENTISTRY—DEMAND UNLIMITED

A paying professional trade: You will be a trained dental mechanic and receive our diploma when competent. Students given advantage of thoroughly up to date laboratory, and services of graduate Dental Surgeons on practical cases. No effort spared to place graduates advantageously. No age limit. Day or Evening. Individual instruction. No educational requirements. No book or home study. Easy terms. Highest references. Especially attractive proposition to those who write at once for catalog H.

inch spark, which was connected with a spark gap, glass plate and tin-foil condenser and a loop antenna or spiral comprising a few turns of heavy wire, about 2 feet in diameter. Several yards distant, Mr. Leroy placed his receiving coil or igniting resonator, which included a loop or heavy copper conductor about three feet in diameter. The action on the device was similar to that of the Hertzian resonator, i. e., whenever the spark coil or transmitting helix were excited, allowing a spark to jump the gap, electromagnetic waves were set up in the intervening ether, causing corresponding currents to be induced or set up in the receiving loop. As in the historic experiments of Hertz, this loop will gather sufficient energy from the etheric waves to cause a small spark to jump a gap connected across the terminals of the loop, as the accompanying diagram clearly shows.

Mr. Leroy carried out many different experiments with his apparatus, placing the glass spark chamber of the igniting resonator in a bath of oil or vaseline, which can be heated when desired by incandescent lamps, etc.

One of the most interesting experiments carried out by Mr. Leroy was that with miniature bales of cotton, which were enclosed in jute wrappers and provided with iron wire bands, in the way cotton is usually packed for shipment. "Spontaneous combustions in cotton warehouses and in shipholds loaded with cotton or similar material, are not always what they seem," says Mr. Leroy, in describing his experiments and results with the radio igniter. One of the hoops encircling the bale of raw cotton may break or become loose under the action of shock or from some other cause, and the gap created by the breaking of the wire, forms a miniature Hertzian resonator. When a wireless station situated in the immediate vicinity, or perhaps at some quite distant point, starts in to transmit (and the more powerful the station the more pronounced the effect and danger from fire of course), currents will be induced in the iron wire around the bales or other packages, and sparks may pass between the various metal members. Especially will they be inclined to jump small gaps in the wire which occur in the immediate loop. We may say right here, that to a layman all of this phenomena may seem somewhat far-fetched, and not within the realm of everyday possibilities, but anyone who has experimented with high frequency currents, as generated from even a small size oscillator, will at once be convinced that these effects can and do take place under most unbelievable conditions. Of course, one objection that the average electrical and radio reader will probably think of, is that if the cotton bales, etc., are placed in a steel vessel, that this metallic hull will act as a screen, and that the bales will not have any current induced in their wire loops, but while this may be partially so, in some cases it is not always so by any means; especially when the home transmitting station, such as on ship-board, starts in operating. In this case, the steel hull of the boat is charged whenever the transmitting key is depressed.

The secret, if so we may call it, of the production of inflammatory sparks or discharges in metallic bodies such as here described, lies in the phenomena known as "resonance." This means that the nearer the metallic members come in tune with the radio waves, the more pronounced the induction effects produced in any instance. It is of course readily conceivable that a cargo of cotton bales presents many peculiar conditions of resonance, due to the varying capacities and inductances of the various loops. In fact, so obvious and possible is this condition, that a wooden vessel carrying bales of cotton or other material having wire or metal members to hold them, and providing she is fitted with a

MATHEMATICIANS

Engineers, Astronomers,
Surveyors, Scientists—

The Mathematical Multiplex contains the characters and signs used for writing in higher and lower mathematics, and for engineering, mechanics, etc., as well as type for all the ordinary work that can be done on any typewriter.

Write for special Folder showing scientific type-sets.

"Just Turn the Knob"

on the

**Hammond
MULTIPLEX**

"Many Typewriters In One"

—and you have a

Different Style of Type



A few Samples of Multiplex Type:

Types for all purposes

and for all languages

Spacing to suit size of type

Perfect alignment

Automatic Type Impression

All on one MULTIPLEX

Over 365

Different Type-Sets

Including All Languages, to Select From

Any one of which may be substituted in a few seconds: "Just Turn the Knob"

The Multiplex does all that any other typewriter will do, and many other things that no other typewriter can do.

The six samples of the Multiplex type reproduced above, show how you can make your writing TALK—a revelation in typewriting!

This marvelous INSTANTLY interchangeable-type feature is only one of the many reasons why these, and thousands of other prominent men and women in all walks of life, and in all four corners of the globe, prefer and personally use the Multiplex:

President Wilson
Queen Alexandria of England
King and Crown Prince of Sweden
Caliph of Morocco
King and Queen of Norway
William Dean Howells Cardinal Merry del Val
Bertha M. Clay Sir James Matthew Barrie
John Kendrick Bangs Walt Mason, Poet
Leigh Mitchell Hodges Wallace Irwin
Prof. L. A. Loiseux Etc., Etc.

Mail the Coupon for FREE BOOKLET

It will show you how, with the Multiplex, you can put the force of emphasis into your typed matter—how you can drive home with strength of accent the fullness of your argument—how you can write with the same convincing force that you use in speaking—an exclusive feature of the Multiplex.

We will also send our pamphlet, "The President and His Typewriter."



Also—An Aluminum
PORTABLE Model

For Traveling—for
Home. Weighs only
about 11 lbs. Full
capacity. Ask for
special folder.

Write your name, address and occupation in the margin below and mail the margin to—

Hammond Typewriter Co., 589 E. 69th St., New York City

YOUR OPPORTUNITY

Canceled Government Contracts

We have secured a large quantity of Small Motors, Generators and Charging Outfits. This material is new, still in original cases and carries the full factory guarantee.

This is Your Opportunity to buy new, guaranteed Electrical Apparatus of Standard Manufacture



Battery Charging Outfits
For use on 110 volt, A. C., 60 cycle, single phase current only.
80 watts, 8 volts, 10 amperes **\$48.50**
150 watts, 50 volts, 6 amperes **\$68.50**
180 watts, 15 volts, 10 amperes **\$68.50**
300 watts, 90 volts, 10 amperes **\$94.50**
All outfits complete with switch-board at cut shown.

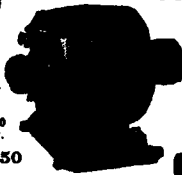

1/2 H. P. INDUCTION MOTOR
110 or 220 volts, A. C.
60 cycle, single phase,
1750 R. P. M.
\$32.50

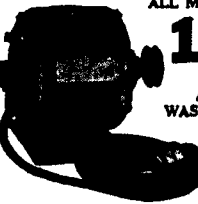

1/4 H. P. 110 volts A. C., 60 cycle, single phase 1760 R. P. M.
\$18.50

ALL MOTORS COMPLETE AS CUT

WASHING MACHINE MOTOR
Bottle for operating Small Commotors, Coffee Grinders, Bottle Washers, Lathe Drill Presses, etc.

Mail \$5.00 cash or Money Order. We will send C. O. D. subject to full examination. **MONEY BACK GUARANTEE**

WRITE FOR CATALOGUE. BARGAINS IN MOTORS AND GENERATORS. SPECIAL QUANTITY PRICES

<p>220 volt POLYPHASE MOTORS 11250 RPM. 60 cycle, 3 or 2 phase. Complete, pulley and base 1 H. P. \$35.50 2 H. P. \$ 54.50 2 H. P. \$72.50 5 H. P. \$102.50</p>	<p>110-220 volt REPULSION MOTORS 1500 RPM. 60 cycle, single phase. Complete with pulley. 1/2 Hp. \$44.50 1 Hp. \$67.50</p>
------------------------------------------------------------------------------------------------------------------------------------------------------------------------------------------	----------------------------------------------------------------------------------------------------------------------------------------------

MANUFACTURERS' DISTRIBUTER
CHAS. H. JOHNSTON - West End - PITTSBURGH, PA.

wireless station of even a few kilowatts, that the Editors would prefer to stay on land than go to sea on such a ship.

One of the accompanying photographs shows how a great multitude of close oscillatory circuits are provided unwittingly in all-framed or rigid gas airships, and even in the non-rigid gas airships there is usually a sufficient amount of metal present in the gondola, wires and other fittings to form one or more resonant circuits, which may cause a spark at an imperfect joint or other gap. It should be remembered, as laboratory tests have demonstrated beyond cavil, that it is not necessary to have a metal wire coil in spiral form in order to have powerful currents induced of sufficient strength to cause a spark to jump from it; a straight metallic wire, bar or even tools, lying within a few yards of a small high frequency coil, will pick up sufficient energy to cause sparks to jump from them, and they will sometimes glow with a vivid brush discharge when viewed in a darkened room.

NATIONAL INSTITUTE OF INVENTORS.

The installation of the officers of the National Institute of Inventors, 118 Fulton Street, New York City, N. Y., was held at the Broadway Central Hotel recently, in the presence of 1,000 guests and members. After a very fine entertainment in which the well-known coloratura-soprano, Miss Edna Blanche Showalter, had rendered selections, and Miss Cecelia Bornstein executed in remarkable fashion her salome dance, the newly elected officers were installed.

Addresses were given by Prof. Chandler, a chemist of international reputation and patent expert; Joseph H. Choate, Jr., who spoke of the founding of the Chemical Foundation, Inc., to which foundation all the German chemical patents had been turned over by former Alien Custodian, Attorney-General Palmer, and an address was made by Thomas Howard, executive chairman of the institute, on the severance and dissociation of the patent office from the Department of the Interior, and the establishing of a Court of Appeals to pass upon patent litigation. He was presented with a medal for faithful services. Refreshments were served and the guests dined until the wee hours of the morning.

The newly elected officers, to serve until 1920, were L. J. Wing, President, pioneer inventor of exhaust fans; Carl Schonert, manufacturer of automobile accessories, of Newark, First Vice-President; Robert C. Lafferty, architect, New York City, Second Vice-President; George Julian Houtain, attorney at law, of 44 Court Street, Brooklyn, Third Vice-President; Milton F. Williams, manufacturer of pulverizers, St. Louis, Mo., Fifth Vice-President; W. H. Kennedy, Recording Secretary; Nathan Langer, Treasurer; Paul Revere Fay, one of the fighting Sixty-ninth, Executive Secretary, and R. Nerenstone, Assistant Executive Secretary.

On the Board of Governors to serve for five years were elected: David Moss, New York City; L. Kenner, New Orleans; Julius Glantz, New York City; Michael Quinane, Paterson, N. J.; J. M. Harding, New York City.

AND WOMAN IS LUCKY TO MAKE ONE MATCH.

One of our newspaper friends—the Oklahoma City Times—quotes us as follows: "The ELECTRICAL EXPERIMENTER tells us that a man contains phosphorus enough to make 800,000 matches, and it might be added that a woman does well to make even one."—(Yes, very well, we'll say she does! With shoes at \$25.00 a throw, dresses at \$100.00 a piece, and food—Ach! Hoover—the needle!! The thought of H. C. L. to-day gives us a fever of 114° in the shade.—Ed.)



Manufacturers and Distributors of
HIGH GRADE
Amateur Wireless Apparatus
Send Stamp for Catalog 40E

J. H. Bunnell & Company
32 Park Place
New York City, New York



EASTERN RADIO INSTITUTE
899 Boylston St.
Boston - Mass.

TEL. BAY BAY 5964

RADIO—Splendid opportunities now in the Merchant Marine for Wireless Operators. Big salaries! New Schedule: Junior operators, \$100 per month; Chief operators, \$125; food and quarters besides. Equivalent ashore from \$40 to \$50 a week. Graduates in all parts of the world as Inspectors, Instructors, Engineers, Operators, etc.

The oldest, largest and best equipped radio school in New England. Recommended by Marconi and Government officials. **DAY AND EVENING CLASSES. START ANY MONDAY.**

"The Eastern" is a Large Achromatic Telescope

JUST WHAT YOU WANT
OVER 2 1/2 FEET LONG

ON SEA FARM OR RANCH

MADE UPON NEW SCIENTIFIC PRINCIPLES.

Positively such a good Telescope was never sold for this price before. Eastern Telescopes are made by one of the largest manufacturers of telescopes in America; we control entire production; measure closed 9 inches and open over 3 feet in 4 sections. They are nicely brass bound, with scientifically ground lenses. Guaranteed by the maker. Every astronomer in the country or at the seaside resorts should certainly secure one of these instruments, and no farmer should be without one. The scenery just now is beautiful, a Telescope will aid you in taking views. Objects are brought to view with astonishing clearness. Sent by mail or express, safely packed, prepaid, for only 99 cents. Our new Catalogue of Watches, etc., sent with each order. This is a grand offer and you should not miss it. We warrant each telescope just as represented or money refunded. Send 99 cents by Registered Letter, Post Office Money Order, Express Money Order, or Bank Draft payable to our order, or your new dealer or store-keeper will order one for you. Whether customer or dealer, send cash with order. To dealers 6 for Four Dollars.

EASTERN NOVELTY CO., 67, 177 E. 93d STREET, NEW YORK

SMOKE IT BEFORE YOU PAY FOR IT

Order on your Business Stationery



To introduce this new and better way to make a pipe we make this extraordinary offer, we will let you smoke this pipe before you pay for it. More than 10,000 BANKERS HAVE BOUGHT BY MAIL. Gentle French Briar, solid Vauclotte mouth piece. Its simple construction makes cleaning easy. Try it. If it is not satisfactory you may return it. Price \$1.50. Straight or Bent Models. You breathe, not pull through this excellent pipe and we guarantee satisfaction.

THE CALUMET CO.
CINCINNATI, OHIO
(Mail Sales Division Dept. A)

New York Herald

Sunday, Oct. 12, 1919, Magazine Section

SIGNALS TO MARS BASED ON HOPE OF LIFE ON PLANET

Written Specially for the Herald by Nikola Tesla

The idea that other planets are inhabited by intelligent beings might be traced to the very beginnings of civilization. This, in itself, would have little significance, for many of the ancient beliefs had their origin in ignorance, fear or other motives - good or evil, and were nothing more than products of untrained or tortured imagination. But when a conception lives through ages in the minds, growing stronger and stronger with increasing knowledge and intellectual development, it may be safely concluded that there is a solid truth underlying the instinctive perception. The individual is short lived and erring; man, relatively speaking, is imperishable and infallible. Even the positive evidences of the sense and the conclusions of science must be hesitatingly accepted when they are directed against the testimony of the entire body of humanity and the experience of centuries.

Modern investigation has disclosed the fact that there are other worlds, situated much the same as ours, and that organic life is bound to develop wherever there is heat, light and moisture. We know now that such conditions exist on innumerable heavenly bodies. In the solar system, two of these are particularly conspicuous - Venus and Mars. The former is, in many respects like the earth and must undoubtedly be the abode of some kind of life, but as to this we can only conjecture, for the surface is hidden from our view by a dense atmosphere. The latter planet can be readily observed and its periodic changes, which have been exhaustively studied by the late Percival Lowell, are a strong argument in support of the supposition that it is populated by a race vastly superior to ours in the mastery of the forces of nature.

If such be the case then all that we can accomplish on this globe is of trifling importance as compared with the perfection of means putting us in possession of the secrets they must have discovered in their struggle against merciless elements. What a tragedy it would be were we to find some day that this wonderful people had finally met its inevitable fate and that all the precious intelligence they might have and, perhaps, had tried to convey to us, was lost. But although scientific research during the last few decades has given substance to the traditional belief, no serious attempt to establish communication could have been made until quite recently for want of proper instrumentalities.

Light Ray Project.

Long ago it was proposed to employ rays of light for this purpose and a number of men of science had devised specific plans which were discussed in the periodicals from time to time. But a careful examination shows that none of them is feasible, even on the assumption that the interplanetary space is devoid of gross matter, being filled only with a homogeneous and inconceivably tenuous medium called the ether. The tails of comets and other phenomena, however, would seem to disprove the theory, so that the successful exchange of signals by that kind of agency is very improbable.

While we can clearly discern the surface of Mars, it does not follow that the reverse is true. In perfect vacuum, of course, a parallel beam of light would be ideally suited for the transmission of energy in any amount for, theoretically, it could pass through infinite distance without any diminution of intensity. Unfortunately, this as well as other forms of radiant energy are rapidly absorbed in traversing the atmosphere.

It is possible that a magnetic force might be produced on the earth sufficient to bridge the gap of 50,000,000 miles and, in fact, it has been suggested to lay a cable around the globe with the object of magnetizing it. But certain electrical

observations I made in studying terrestrial disturbances prove conclusively that there can not be much iron or other magnetic bodies in the earth beyond the insignificant quantity in the crust. Everything indicates that it is virtually a ball of glass and it would require many energizing turns to produce perceptible effects at great distance in this manner. Moreover, such an undertaking would be costly and, on account of the low speed of the current through the cable, the signalling would be extremely slow.

The Miracle Performed.

Such was the state of things until twenty years ago when a way was found to perform this miracle. It calls for nothing more than a determined effort and a feat in electrical engineering which, although difficult, is certainly realizable.

In 1899 I undertook to develop a powerful wireless transmitter and to ascertain the mode in which the waves were propagated through the earth. This was indispensable in order to apply my system intelligently for commercial purposes and, after careful study, I selected the high plateau of Colorado (6,000 feet above sea level) for the plant which I erected in the first part of that year. My success in overcoming the technical difficulties was greater than I had expected and in a few months I was able to produce electrical actions comparable to, and in a certain sense surpassing those of lightning. Activities of 18,000,000 horsepower were readily attained and I frequently computed the intensity of the effect in remote localities. During my experiments there, Mars was at a relatively small distance from us and, in that dry and rarefied air, Venus appeared so large and bright that it might have been mistaken for one of those military signaling lights. Its observation prompted me to calculate the energy transmitted by a powerful oscillator at 50,000,000 miles, and I came to the conclusion that it was sufficient to exert a noticeable influence on a delicate receiver of the kind I was, in the meanwhile, perfecting.

My first announcements to this effect were received with incredulity but merely because the potencies of the instrument I had devised were unknown. In the succeeding year, however, I designed a machine for a maximum activity of 1,000,000,000 horsepower which was partly constructed on Long Island in 1902 and would have been put in operation but for reverses and the fact that my project was too far in advance of the time.

It was reported at that period that my tower was intended for signalling to Mars, which was not the case, but it is true that I made a special provision for rendering it suitable to experiments in that direction. For the last few years there has been such a wide application of my wireless transmitter that experts have become, to an extent, familiar with its possibilities, and, if I am not mistaken, there are very few "doubting Thomases" now. But our ability to convey a signal across the gulf separating us from our neighboring planets would be of no avail if they are dead and barren or inhabited by races still undeveloped. Our hope that it might be different rests on what the telescope has revealed, but not on this alone.

Vast Power Found.

In the course of my investigations of terrestrial electrical disturbances in Colorado I employed a receiver, the sensitiveness of which is virtually unlimited. It is generally believed that the so-called audion excels all others in this respect and Sir Oliver Lodge is credited with saying that it has been the means of achieving wireless telephony and transforming atomic energy. If the news is correct that scientist must have been victimized by some playful spirits with whom he is communicating. Of course, there is no conversion of atomic energy in such a bulb and many devices are known which can be used in the art with success.

My arrangements enable me to make a number of discoveries, some of which I have already announced in technical periodicals. The conditions under which I operated

were very favorable for no other wireless plant of any considerable power existed and the effects I observed were thereafter due to natural causes, terrestrial or cosmic. I gradually learned how to distinguish in my receiver and eliminate certain actions and on one of these occasions my ear barely caught signals coming in regular succession which could not have been produced on the earth, caused by any solar or lunar action or by the influence of Venus, and the possibility that they might have come from Mars flashed upon my mind. In later years I have bitterly regretted that I yielded to the excitement of ideas and pressure of business instead of concentrating all my energies on that investigation.

The time is ripe now to make a systematic study of this transcending problem, the consummation of which may mean untold blessings to the human race. Capital should be liberally provided and a body of competent experts formed to examine all the plans proposed and to assist in carrying out the best. The mere initiation of such a project in these uncertain and revolutionary times would result in a benefit which cannot be underestimated. In my early proposals I have advocated the application of fundamental mathematical principles for reaching the first elementary understanding. But since that time I have devised a plan akin to picture transmission through which knowledge of form could be conveyed and the barriers to the mutual exchange of ideas largely removed.

Success in Trials

Perfect success cannot be attained in any other way for we know only what we can visualize. Without perception of form there is not precise knowledge. A number of types of apparatus have been already invented with which transmission of pictures has been effected through the medium of wires, and they can be operated with equal facility by the wireless method. Some of these are of primitively simple construction. They are based on the employment of like parts which move in synchronism and transmit in this manner records, however complex. It would not require an extraordinary effort of the minds to hit upon this plan and devise instruments on this or similar principles and by gradual trials finally arrive at a full understanding.

The Herald of Sept. 24 contains a dispatch announcing that Prof. David Todd, of Amhurst College, contemplates an attempt to communicate with the inhabitants of Mars. The idea is to rise in a balloon to a height of about 50,000 feet with the manifest purpose of overcoming the impediments of the dense air stratum. I do not wish to comment adversely upon this undertaking beyond saying that no material advantage will be obtained by this method, for what is gained by height is offset a thousandfold by the inability of using powerful and complex transmitting and receiving apparatus. The physical stress and danger confronting the navigator at such an altitude are very great and he would be likely to lose his life or be permanently injured. In their recent record flights Roelfs and Schroeder have found that at a height of about six miles all their force was virtually exhausted. It would not have taken much more to terminate their careers fatally. If Prof. Todd wants to brave these perils he will have to provide special means of protection and these will be an obstacle to his observations. It is more likely, however, that he merely desires to look at the planet through a telescope in the hope of discerning something new. But it is by no means certain this instrument will be efficient under such conditions.

Electrical World
 Sept. 24, 1921 p. 620

INTERPLANETARY COMMUNICATION

To the Editors of the *Electrical World*:

There are countless worlds such as ours in the universe - planets revolving around their suns in elliptical orbits and spinning on their axes like gigantic tops. They are composed of the same elements and subject to the same forces as the earth. Inevitably at some period in their evolution light, heat and moisture are bound to be present, when inorganic matter will begin to run into organic forms. The first impulse is probably given by heliotropism; then other influences assert themselves, and in the course of ages, through continuous adjustment to the environment, automata of inconceivable complexity of structure result. In the workshop of nature these automatic engines are turned out in all essential respects alike and exposed to the same external influences.

The identity of construction and sameness of environment result in a concordance of action, giving birth to reason; thus intelligence, as the human, is gradually developed. The chief controlling agent in this process must be radiant energy acting upon a sense organ as the eye, which conveys a true conception of form. We may therefore conclude with certitude that, however constructively different may be the automata on other planets, their response to rays of light and their perceptions of the outside world must be similar to a degree so that the difficulties in the way of mutual understanding should not be insuperable.

Irrespective of astronomical and electrical evidences, such as have been obtained by the late Percival Lowell and myself, there is a solid foundation for a systematic attempt to establish communication with one of our heavenly neighbors, as Mars, which through some inventions of mine is reduced to a comparatively simple problem of electrical engineering. Others may scoff at this suggestion or treat it as a practical joke, but I have been in deep earnest about it ever since I made the first observations at my wireless plant in Colorado Springs from 1889 to 1900. Those who are interested in the subject may be referred to my articles in the *Century Magazine* of June, 1900, *Collier's Weekly* of Feb. 9, 1901, the *Harvard Illustrated Magazine* of March, 1907, the *New York Times* of May 23, 1909, and the *New York Herald* of Oct. 12, 1919.

At the time I carried on those investigations there existed no wireless plant on the globe other than mine, at least none that could produce a disturbance perceptible in a radius of more than a few miles. Furthermore, the conditions under which I operated were ideal, and I was well trained for the work. The arrangement of my receiving apparatus and the character of the disturbances recorded precluded the possibility of their being of terrestrial origin, and I also eliminated the influence of the sun, moon and Venus. As I then announced, the signals consisted in a regular repetition of numbers, and subsequent study convinced me that they must have emanated from Mars, this planet having been just then close to the earth.

Since 1900 I have spent a great deal of my time in trying to develop a thoroughly practical apparatus for the purpose and have evolved numerous designs. In one of these I find that an activity of 10,000,000,000 hp in effective wave energy could be attained. Assuming the most unfavorable conditions - namely, half-spherical propagation - then at a distance of 34,000,000 miles the energy rate would be about 1/730,000 hp per square mile, which is far more than necessary to affect a properly designed receiver. In fact, apparatus similar to that used in the transmission of pictures could be operated, and in this manner mathematical, geometrical and other accurate information could be conveyed.

I was naturally very much interested in reports given out about two years ago that similar observations had been made, but soon ascertained that these supposed

planetary signals were nothing else than interfering undertones of wireless transmitters, and since I announced this fact other experts have apparently taken the same view. These disturbances I observed for the first time from 1906 to 1907. At that time they occurred rarely, but subsequently they increased in frequency. Every transmitter emits undertones, and these give by interference long beats, the wave length being anything from 50 miles to 300 or 400 miles. In all probability they would have been observed by many other experimenters if it were not so troublesome to prepare receiving circuits suitable for such long waves.

The idea that they would be used in interplanetary signaling by any intelligent beings is too absurd to be seriously commented upon. These waves have no suitable relation to any dimensions, physical constants or succession of events, such as would be naturally and logically considered in an intelligent attempt to communicate with us, and every student familiar with the fundamental theoretical principles will readily see that such waves would be entirely ineffective. The activity being inversely as the cube of the wave length, a short wave would be immensely more efficient as a means for planetary signaling, and we must assume that any beings who had mastered the art would also be possessed of this knowledge. On careful reflection I find, however, that the disturbances as reported, if they have been actually noted, cannot be anything else but forced vibrations of a transmitter and in all likelihood beats of undertones.

While I am not prepared to discuss the various aspects of this subject at length, I may say that a skillful experimenter who is in the position to expend considerable money and time will undoubtedly detect waves of about 25,470,000 m.

Nikola Tesla
New York City.

Reprinted with permission. Reprinted from September 24, 1921, issue of *Electrical World*. © Copyright 1921, McGraw-Hill, Inc. All rights reserved.

New York Evening Post
Sept. 26, 1921

NIKOLA TESLA ON ELECTRIC TRANSMISSION

To the Editor of the New York Evening Post:

Sir: Your issue of the 14th inst. contains a report relative to an experimental demonstration at the Pittsfield plant of the General Electric Company in which a pressure of one million volts was used for transmission of power by alternating currents. This is said to be the result of more than thirty years' work and to constitute a dramatic advance in electrical development so much, indeed, that it was deemed proper to record the time of its consummation with greater precision than that when Joshua commanded the sun to stand still over Gibeon and the moon in the Valley of Ajalon. But the prosaic fact is that I have long ago perfected and patented the invention instrumental in this achievement and applied it successfully in the production of pressures amounting to many millions of volts. It may not be amiss to state furthermore that a license was offered to the General Electric Company under my basic patent which bears the No. 1,119,732 and was granted December 1, 1914, the original application having been filed January 16, 1902.

The economic transmission of electrical energy at great distances necessitates the employment of very high pressures and at the outset two serious difficulties were encountered in their application. One was the breaking down of the insulation under the excessive stress. Upon careful investigation of the causes, I found that this was due to the presence of air or gas bubbles which were heated by the action of the currents and impaired the resisting quality of the dielectric. The trouble was done away with entirely by a process of manufacture developed by me which has been universally adopted. But the second obstacle was much harder to overcome. It was met in the apparent impossibility of confining the high tension flow to the conductors. In my early experiments I covered them with the best insulating material, several inches thick, but it was of no avail. Finally my efforts were rewarded and I found a simple and perfect remedy.

An idea of the underlying principle of the invention and its practical significance may be conveyed by an analogue. Alternating currents transmitted through a wire can be likened to pulses of some liquid, as water, forced through a woven hose. So long as the pressure is moderate the fluid entering one end will be integrally discharged at the other, but if the pressure is increased beyond a certain critical value the hose will leak and a large portion of the fluid may thus be wasted. Similarly in electric transmission, when the voltage becomes excessive the prison walls of the dielectric yield and the charge escapes. The loss of energy occasioned thereby, although emphasized by engineers, is not a fatal drawback; the real harm lies in the limitation thus imposed to the attainment of many results of immense value. Now, what I did was equivalent to making the hose capable of withstanding any desired pressure, however great. This was accomplished by so constructing the transmitting conductor that its outer surface has itself a large radius of curvature or is composed of separate parts which, irrespective of their own curvature, are arranged in proximity to one another and on an ideal enveloping symmetrical surface of large radius. These parts may be in the shape of shells, hoods, discs, cylinders, or strands, according to the requirement in each special case, but it is always essential that the aggregate outer conducting area be considerable.

I believe that many arts and industries will be revolutionized through the application of the enormous electric pressures which are easily producible by this means, but perhaps the purely scientific results will be more important than the commercial.

N. Tesla
New York, September 23.

New York Herald Tribune
 Sept. 22, 1929, pp. 1, 29.

NIKOLA TESLA TELLS OF NEW RADIO THEORIES - Does Not Believe in Hertz Waves and Heaviside Layer, Interview Discloses

The model of a "Tesla Coil" which will be featured in the historic exhibit of the radio show reawakens interest in its inventor.

It is not generally appreciated that this curious apparatus, often associated with pretty or spectacular demonstrations of high voltage electricity, is really a fundamental part of modern radio. For all the tuning apparatus and circuits in every transmitting and receiving set are simply variations of Tesla coils and Tesla coil circuits.

It was for this invention, and other inventions and principles concerned with tuning, heterodyning, and the generation of continuous waves, which were made at least several years before the very first experiments of Marconi, that many of our most reputable engineers have conceded to Nikola Tesla the title of "Father of Radio".

Mr. Tesla, still actively working, was interviewed last week to get his ideas regarding the prospects of the radio of 1930, and beyond. As a prophet, however, he balked. He had repeated time and again his visions for the future. As far back as 1900, he had contemplated a world-wireless system which included broadcasting, picture transmission, international time service, and in addition television and the distribution of electrical power. Part of this early prophecy has been realized -- what remained, still stood as his prediction.

Disputes Hertz Waves.

What, then, about power transmission by radio? Laurence M. Cockaday, the technical editor of this radio section, had expressed the opinion several weeks ago that, with present apparatus at least, it was hardly feasible. Mr. Tesla agreed to discuss the point at length. As a result, he made public for the first time one of the most extraordinary conclusions - that Hertz waves do not exist! If his theory is true, there may be found in it more adequate explanations of "dead spots", fading, reflection and a dozen other problems that have always puzzled the profession.

The inventor began by referring to Cockaday's article:

"I have read the article, and I quite agree with the opinion expressed -- that wireless power transmission is impractical with present apparatus. This conclusion will be naturally reached by any one who recognizes the nature of the agent by which the impulses are transmitted in present wireless practice.

"When Dr. Heinrich Hertz undertook his experiments from 1887 to 1889 his object was to demonstrate a theory postulating a medium filling all space, called the ether, which was structureless, of inconceivable tenuity and yet solid and possessed of rigidity incomparably greater than that of the hardest steel. He obtained certain results and the whole world acclaimed them as an experimental verification of that cherished theory. But in reality what he observed tended to prove just its fallacy.

"I had maintained for many years before that such a medium as supposed could not exist, and that we must rather accept the view that all space is filled with a gaseous substance. On repeating the Hertz experiments with much improved and very powerful apparatus, I satisfied myself that what he had observed was nothing else but effects of longitudinal waves in a gaseous medium, that is to say, waves, propagated by alternate compression and expansion. He had observed waves in the ether much of the nature of sound waves in the air.

"Up to 1896, however, I did not succeed in obtaining a positive experimental proof of the existence of such a medium. But in that year I brought out a new form of vacuum tube capable of being charged to any desired potential, and operated it with effective pressures of about 4,000,000 volts. I produced cathodic and other rays of transcending intensity. The effects, according to my view, were due to minute particles of matter carrying enormous electrical charges, which, for want of a better name, I designated as matter not further decomposable. Subsequently those particles were called electrons.

"One of the first striking observations made with my tubes was that a purplish glow for several feet around the end of the tube was formed, and I readily ascertained that it was due to the escape of the charges of the particles as soon as they passed out into the air; for it was only in a nearly perfect vacuum that these charges could be confined to them. The coronal discharge proved that there must be a medium besides air in the space, composed of particles immeasurably smaller than those of air, as otherwise such a discharge would not be possible. On further investigation I found that this gas was so light that a volume equal to that of the earth would weigh only about one-twentieth of a pound.

"The velocity of any sound wave depends on a certain ratio between elasticity and density, and for this ether or universal gas the ratio is 800,000,000,000 times greater than for air. This means that the velocity of the sound waves propagated through the ether is about 300,000 times greater than that of the sound waves in air, which travel at approximately 1,085 feet a second. Consequently the speed in ether is $900,000 \times 1,085$ feet, or 186,000 miles, and that is the speed of light.

"As the waves of this kind are all the more penetrative the shorter they are, I have for years urged the wireless experts to use such waves in order to get good results, but it took a long time before they settled upon this practice.

"Although the world is still skeptical as to the feasibility of my undertaking, I note that some advanced experts, at least, share my views, and I hope that before long wireless power transmission will be as common as transmission by wires."

According to Mr. Tesla, the present broadcasting station does not propagate Hertzian waves, as has always been supposed, but acts more like an "ether whistle" - transmitting waves through the ether similar to the waves transmitted by an ordinary whistle through the air. He also expressed his disbelief in the Heavenside layer, and claimed that the reflection of waves back toward the earth was due to the change of medium encountered at the vacuous boundary of the atmosphere.

At Colorado Springs, about thirty years ago, this scientist had a Tesla coil seventy-five feet in diameter which produced voltages above 12,000,000, and sparks over 100 feet long. Electrical flashes were created which were the nearest approach to lightning that man has ever made. During his experiments there, of over a year, Tesla claims that he transmitted a considerable amount of electrical current to the other side of the earth. It was upon these, and later experiments that he bases his present prediction.

New York World

Nov. 29, 1929, p. 10, cols. 4,5.

MR. TESLA SPEAKS OUT

To the Editor of the World:

Permit me a few words of comment relative to The World editorial of Oct. 21 in which I am directly concerned.

Edison's work on the incandescent lamp and direct-current system of distribution was more like the performance of an extraordinarily energetic and horse-sensed pioneer than that of an inventor; it was prodigious in amount, but not creative. The lamp itself, consisting of a carbon filament in an exhausted globe, was well known and even patented years before. Crookes had employed incandescent conductors with leading-in platinum wires sealed in the glass and obtained extremely high vacua: the multiple-arc arrangement was frequently shown at institutions of learning, display windows and exhibitions with Geissler tubes; electric generators had been constructed, means for regulating current and voltage described and canalization of electricity was as obvious as that of water, gas, compressed air or other commodity.

Irrespective of this, however, his primitive scheme of lighting was subject to fatal economic limitations and could have never proved a commercial success in competition. Indeed, during the past thirty-five years it has been almost wholly displaced by a more practical and efficient system based on my rotating magnetic field, a discovery which even hard-headed engineers and patent lawyers have declared to be "one of the greatest triumphs of the human mind." To convey an idea of the extent of its use I only need to quote Dr. B. A. Behrend, one of the foremost electrical experts, who in his book on the induction motor says: "Were we to eliminate from our industrial world the results of Mr. Tesla's work the wheels of industry would cease to turn, our electric trains and cars would stop, our towns would be dark, our mills dead and idle. So far-reaching is this work that it has become the warp and woof of industry."

Edison and his associates bitterly opposed the introduction of my system, raising a clamor against the "deadliness" of the alternating current, which proved very effective and led to the adoption of a commercial type of machine in electrocution of criminals, an apparatus monstrously unsuitable, for the poor wretches are not despatched in a merciful manner but literally roasted alive. To the observer their sufferings seem to be of short duration; it must be borne in mind, though, that an individual under such conditions, while wholly bereft of the consciousness of the lapse of time, retains a keen sense of pain, and a minute of agony is equivalent to that through all eternity.

Had the Edison companies not finally adopted my invention they would have been wiped out of existence, and yet not the slightest acknowledgment of my labors has ever been made by any of them, a most remarkable instance of the proverbial unfairness and ingratitude of corporations. But the reason is not far to see. One of their prominent men told me that they are spending \$10,000,000 every year to keep Edison's name before the public, and he added that it is worth more to them. Of course, in all that unceasing and deafening shouting from the housetops any voice raised to apprise people of the real state of things is like the chirp of a little sparrow in the roar of Niagara. So it comes that very few have a clear idea of the situation.

In truth, my system has not only provided energy for all purposes throughout the world but also revolutionized electric lighting and made it a great commercial success by reducing the cost of power and increasing enormously the distance of transmission. The greater part of the \$60,000,000,000 which, according to

President Hoover's statement, represented the value of electric business, can be traced to my system and its effect on the lighting and other industries. In view of this I feel that I also have done much to dispel darkness. Surely, my system is more important than the incandescent lamp, which is but one of the known electric illuminating devices and admittedly not the best. Although greatly improved through chemical and metallurgical advances and skill of artisans it is still inefficient, and the glaring filament emits hurtful rays responsible for millions of bald heads and spoiled eyes. In my opinion, it will soon be superseded by the electrodeless vacuum tube which I brought out thirty-eight years ago, a lamp much more economical and yielding a light of indescribable beauty and softness. The technical resources of that time were inadequate to make it a practical success, but most of the difficulties will be overcome when cheap quartz glass becomes available.

No amount of praise is too much to bestow upon Edison for his vigorous pioneer work, but all he did was wrought in known and passing forms. What I contributed constitutes a new and lasting addition to human knowledge. Like his lamp, my induction motor may be discarded and forgotten in the continuous evolution of the arts, but my rotating field with its marvelous phenomena and manifestations of force will live as long as science itself.

NIKOLA TESLA
New York, Nov. 5

New York World
April 13, 1930

To the Editor of The World:

The World editorial March 28 must have instilled a holy fear in the minds of some of your readers. Of course Marconi could not help astounding people, but surely it was wrong of him at this critical time to scare the United States Navy by the statement that he could halt the progress of electrically driven dreadnoughts, which would mean certain doom in an engagement with the enemy. The thought that my beautiful induction motors used in their propulsion might be consigned to Davy Jones' locker in this easy manner caused me some anxiety until I satisfied myself by a little calculation that the maximum power transmitted - expressed in units more appropriate than the conventional - did not exceed one-millionth of a "mouse-power."

Except to the layman there was nothing remarkable in the performance, considering that sea water has only one five-hundredths of the resistance of solid ground and that there were no towering objects in the vicinity, thus reducing very much the size of the plant, Marconi accomplished nothing more than was known before. The infinitesimal currents received were amplified, relayed repeatedly and made to actuate local means, as usual. This can be brought about in more than one way; but as a rule, a form of amplifying three-electrode tubes is employed which I described in my experimental lectures before the Franklin Institute and National Electric Light Association early in 1893. The modern tubes embodying the same principle are marvels of workmanship, but less sensitive, because they lend themselves only to relatively small voltages. If suitable means were provided, any wireless amateur could magnify as feeble a disturbance as the patter of feet of a fly sufficiently to precipitate a veritable earthquake at the antipodes. The shrewd Italian did not give a description of his apparatus, but from his previous records one may safely infer that it is old and well known. It is gratifying, however, that he has abandoned the ridiculous arrangement of a "beam system," which he claimed to offer "limitless possibilities."

Your reference to this first announcement thirty years ago has stirred up in my memory unpleasant recollections. To the public the transmission of a weak wireless signal across the Atlantic appeared almost like a miracle, but, even if a fact, it was a paltry engineering achievement, for I had already shown by experiment over a year before that the earth may be excited like a wire of small dimensions and that current impulse from a powerful transmitter could travel through it as much as a million times before its energy was exhausted. But this is immaterial. I only wish to call the attention of your readers to the circumstances.

Some time after the experiments with the classical Hertz devices conducted under the auspices of the Imperial Post Office in England, Sir William Preece, then head of the department, wrote me a letter conveying the information that the tests had been abandoned as of no value, but that he believed good results possible by my system. In reply I offered to prepare two sets for trial and asked him to give me the technical particulars necessary to the design. Just then Marconi came out with the emphatic assertion that he had tried out my apparatus and that it did not work. Evidently he succeeded in his purpose, for nothing was done in regard to my proposal.

He furthermore declared at a later date that wireless communication across the Atlantic was impossible because there was a wall of water several miles high between the two continents which the rays could not traverse. But subsequent developments showed that he had used my system in secret all the time, received the plaudits of the world and accepted stolidly even my own congratulations, and it was only a long time after that he admitted it.

NIKOLA TESLA.
New York, April 11.

• Our Future

By NIKOLA

IN this instructive article, the great scientist and inventor who revolutionized industry and communication with his alternating current motors and distributing system, and opened the way for radio with his high-frequency researches, analyzes the problem of obtaining power to replace our wasted fuel, and indicates the method of tapping the earth's hidden resources which will support the industry of future generations.

THE material as well as intellectual progress of Man is becoming ever more dependent on the natural forces and energies he is putting to his service. While not exactly a true measure of well being and enlightenment, the amount of power used is a reliable indication of the degree of safety, comfort and convenience, without which the human race would be subject to increasing suffering and want and civilization might perish.

Virtually all our energies are derived from the sun, and the greatest triumph we have achieved in the utilization of its undying fire is the harnessing of waterfalls. The hydro-electric process, now universally employed, enables us to obtain as much as eighty-five per cent of the solar energy with machines of elementary simplicity which, by resorting to the latest improvements in the technical arts, might be made capable of enduring for centuries. These advantages are entirely exceptional, very serious handicaps and great, unavoidable losses confronting us in all other transformations of the forces of nature. It is, therefore, desirable in the interest of the world as a whole, that this precious resource should be exploited to the limit. Judging from the average height of the water discharged annually from the clouds, and the mean fall over the aggregate land surface, the total terrestrial water power may be theoretically estimated at ten billions of horse power. Of course, only a part of that is suited for practical development and relatively little is actually utilized—twenty-five per cent, perhaps, in the most advanced countries, less in others, and there are some in which not even the ground has been broken. Great waterfalls exist in many inaccessible regions of the globe and new ones are being discovered, all of which will be eventually harnessed when the wireless transmission of energy is commercialized. There is foundation for hope, however, that our present limitations in the amount of the available power may be removed in the future. Three-quarters of the earth's surface are covered by the oceans and the rainfall over all this vast area is useless

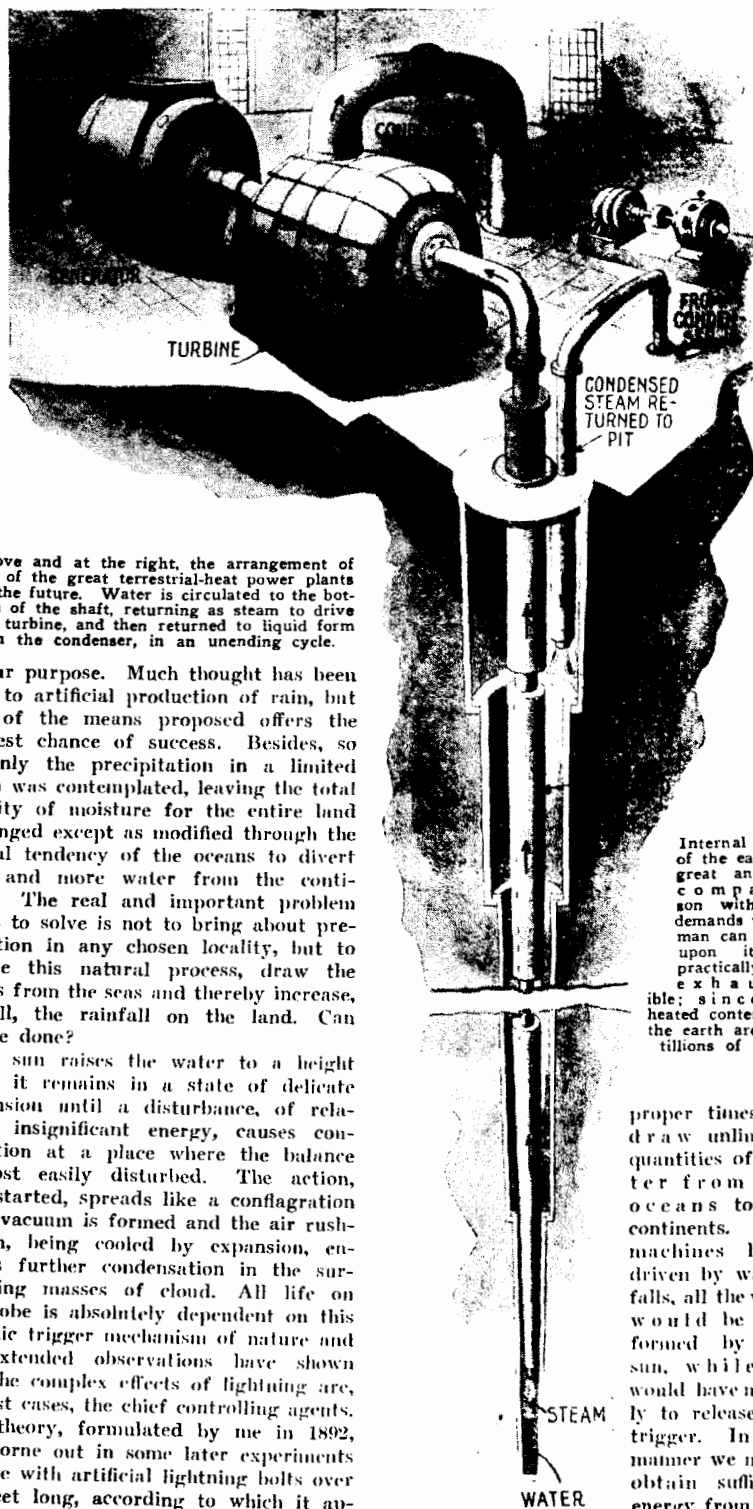

Above and at the right, the arrangement of one of the great terrestrial-heat power plants of the future. Water is circulated to the bottom of the shaft, returning as steam to drive the turbine, and then returned to liquid form in the condenser, in an unending cycle.

for our purpose. Much thought has been given to artificial production of rain, but none of the means proposed offers the slightest chance of success. Besides, so far only the precipitation in a limited region was contemplated, leaving the total quantity of moisture for the entire land unchanged except as modified through the natural tendency of the oceans to divert more and more water from the continents. The real and important problem for us to solve is not to bring about precipitation in any chosen locality, but to reverse this natural process, draw the vapors from the seas and thereby increase, at will, the rainfall on the land. Can this be done?

The sun raises the water to a height where it remains in a state of delicate suspension until a disturbance, of relatively insignificant energy, causes condensation at a place where the balance is most easily disturbed. The action, once started, spreads like a conflagration for a vacuum is formed and the air rushing in, being cooled by expansion, enhances further condensation in the surrounding masses of cloud. All life on the globe is absolutely dependent on this gigantic trigger mechanism of nature and my extended observations have shown that the complex effects of lightning are, in most cases, the chief controlling agents. This theory, formulated by me in 1892, was borne out in some later experiments I made with artificial lightning bolts over 100 feet long, according to which it appears possible, by great power plants suitably distributed and operated at the

Internal heat of the earth is great and, in comparison with the demands which man can make upon it, is practically inexhaustible: since the heated contents of the earth are sextillions of tons.

proper times, to draw unlimited quantities of water from the oceans to the continents. The machines being driven by waterfalls, all the work would be performed by the sun, while we would have merely to release the trigger. In this manner we might obtain sufficient energy from falling water to provide for all our

Motive Power •

TESLA



The ambitious scheme proposed here draws power from the depths of the sea, utilizing the warmth of one layer, brought into contact with the cold of another, to operate great power plants. Its practicability, as well as the theory of its operation, is analyzed in this remarkable article.

extending. It is quite evident, though, that this squandering cannot go on indefinitely, for geological investigations prove our fuel stores to be limited.

So great has been the drain on them of late years that the specter of exhaustion is looming up threateningly in the distance, and everywhere the minds of engineers and inventors are bent upon increasing the efficiency of known methods and discovering new sources of power.

Nature has provided an abundant supply of energy in various forms which might be economically utilized if proper means and ways can be devised. The sun's rays falling upon the earth's surface represent a quantity of energy so enormous that but a small part of it could meet all our demands. By normal incidence

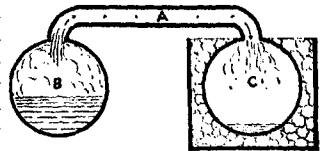

The "cryophorus" is well known as a scientific toy, exemplifying also the principle of refrigerating machinery.

necessities. More than this, we could create new lakes and rivers, induce a luxuriant flora and fauna and convert even the arid sands of deserts into rich, fertile soil.

But the full realization of this idea is very remote. The hard fact is that unless new resources are opened up, energy derived from fuel will remain our chief reliance. The thermodynamic process is wasteful and barbarous, especially when burning coal, the mining of which, despite of modern improvements, still involves untold hardships and dangers to the unfortunates who are condemned to toil deep in the bowels of the earth. Oil and natural gas are immensely superior in this and other respects and their use is rapidly

the rate is mechanically equivalent to about 95 foot pounds per square foot per second, or nearly 7300 horse power per acre of ground. In the equatorial regions the mean annual rate is approximately 2326 and in our latitudes 1737 horse power for the same area. By using the heat to generate steam and operating a turbine under high vacuum probably 200 horse-power per acre could be obtained as net useful power in these parts. This would be very satisfactory were it not for the cost of the apparatus which is greatly increased by the necessity of employing a storage plant sufficient to carry the load almost three-quarters of the time.

The energy of light rays, constituting about 10% of the total radiation, might be captured by a cold and highly efficient process in photo-electric cells which may become, on this account, of practical importance in the future. Some progress in this direction has been already achieved. But for the time being it appears from a careful estimate, that solar power derived from radiant heat and light, even in the tropics, offers small opportunities for practical exploitation. The existing handicaps will be largely removed when the wireless method of power transmission comes into use. Many plants situated in hot zones, could then be operatively connected in a great

super-power system to supply energy, at a constant rate, to all points of the globe.

The sun emits, however, a peculiar radiation of great energy which I discovered in 1899. Two years previous I had been engaged in an investigation of radioactivity which led me to the conclusion that the phenomena observed were not due to molecular forces residing in the substances themselves, but were caused by a cosmic ray of extraordinary penetrativeness. That it emanated from the sun was an obvious inference, for although many heavenly bodies are undoubtedly possessed of a similar property, the total radiation which the earth receives from all the suns and stars of the universe is only a little more than one-quarter of one per cent of that it gets from our luminary. Hence, to look for the cosmic ray elsewhere is much like "chercher le midi dans les environs de quatorze heures." My theory was strikingly confirmed when I found that the sun does, indeed, emit a ray marvelous in the inconceivable minuteness of its particles and transcending speed of their motion, vastly exceeding that of light. This ray, by impinging against the cosmic dust generates a secondary radiation, relatively very feeble but fairly penetrative, the intensity of which is, of course, almost the same in all directions. German scientists who investigated it in 1901 assumed that it came from the stars and since that time the fantastic idea has been advanced that it has its origin in new matter constantly created in interstellar space!! We may be sure that there is no place in the universe where such a flagrant violation of natural laws, as the flowing of water uphill, is possible. Perhaps, some time in the future when our means of investigation will be im-

measurably improved, we may find ways of capturing this force and utilizing it for the attainment of results beyond our present imagining.

The tides are often considered as a source of motive power and not a few engineers have expressed themselves favorably in regard to their use. But as a matter of fact, the energy is, in most places, insignificant, the harnessing of the waterfall over an acre of ground yielding but little more than one horse power. Only in exceptional locations can the power of the tides be profitably developed.

It has been the dream of many an in-

ventor to utilize the energy of ocean waves, which is considerable. But although numerous schemes have been advanced and much ingenuity shown in devising the mechanical means, nothing of

commercial value has so far resulted and the prospects are very poor on account of technical difficulties and the erratic character of this power source.

The force of the wind can be much more easily put to our service and has been in practical use since times immemorial. It is invaluable in ship propulsion and the windmill must be seriously regarded as a power generator. If the cost of this commodity should greatly increase we will be likely to see the countries dotted with these time-honored contrivances.

Unfortunately, the value of all these resources is very much reduced by periodic and casual variations, and we are driven to search for a source of constant

twenty-four hour power comparable to that of a waterfall. Thus we are led to consider terrestrial heat as a possible fountain of unvarying energy supply.

Terrestrial Energy

It is noteworthy that already in 1852 Lord Kelvin called attention to natural heat as a source of power available to Man. But, contrary to his habit of going to the bottom of every subject of his investigations, he contented himself with the mere suggestion. Later, when the laws of thermo-dynamics became well understood, the prospects of utilizing temperature differences in the ocean, solid earth or the atmosphere, have been often examined. It is well known that there exists, in tropical seas, a difference of 50° F. between the surface water and that three miles below. The temperature of the former, being subject to variations, averages 82° F., while that of the latter is normally at least, at 32° F., or nearly so, as the result of the slow influx of the ice-cold polar stream. In solid land these relations are reversed, the temperature increasing about one degree

Fahr. for every 64 feet of descent. Very great differences are also known to exist in the atmosphere, the temperature diminishing with the distance above the earth's surface according to a complex function. But while all this was of common knowledge for at least 75 years and the utilization of the heat of the earth for power purposes a subject of speculation, no decided attempt to this end seems to have been made until an American engineer, whose name I have been unable to ascertain, proposed to operate engines by steam generated in high vacuum from the warm surface water and condensed by the cold water pumped from a great depth. A fully and (Continued on page 78)

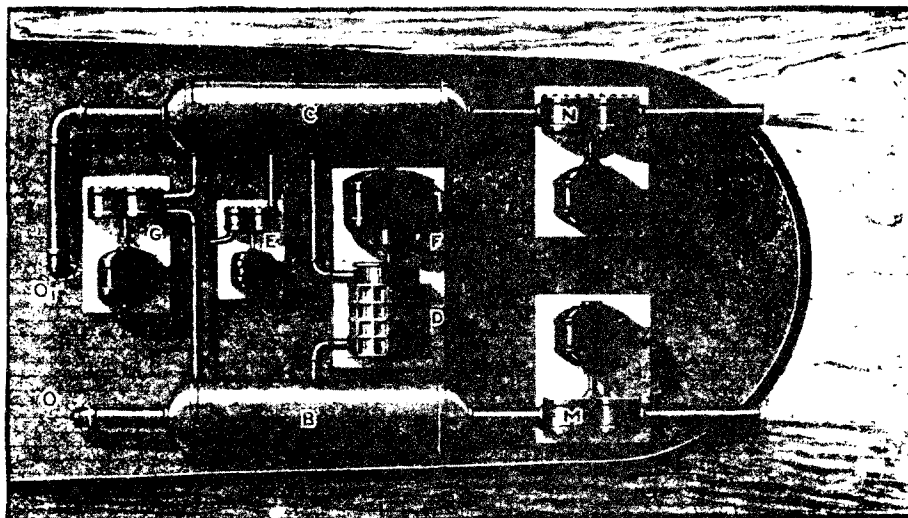

FIG. 7 Design of a vessel to be propelled by energy derived from temperature differences in the water. The symbols designating the operating mechanism are explained in the text.

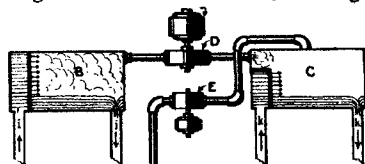

FIG. 3 A more complete sketch of the thermodynamic system, in which the necessary degree of vacuum is produced by the suction pump E.

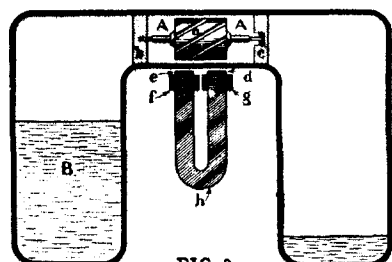

FIG. 2 Fundamental plan of a system whereby the transfer of vapor between two vessels at different temperatures drives the armature of an electrical generator.

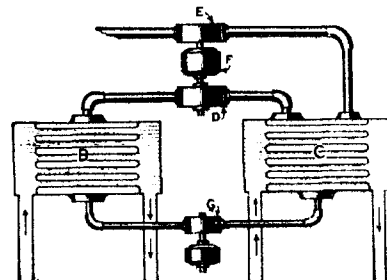
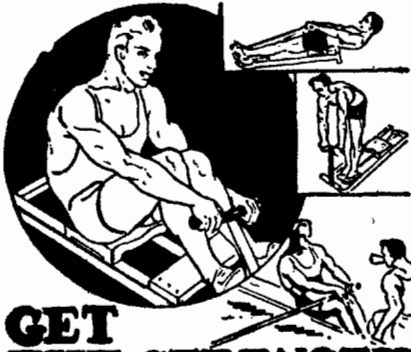

FIG. 4 Here the water, or other fluid operating the turbine D is kept in a closed system, circulating through condensers immersed in water of different temperatures.



GET THE STRENGTH OF AN OARSMAN

A Gym at Home to Make You Strong

Get Strong! Enjoy the thrill which giant strength gives to the varsity oarsman. He must be "there" to stand the strain and endure the greatest and most terrific strength test put to any athlete. If you want massive shoulders—a mighty chest—arms like iron—a powerful back—legs like pillars of steel and an all around perfect athlete's body, stop dreaming. Wake up! The invention of the Vig-Row is the answer to your dream. The Vig-Row was created and built by a man who built his own body from a weakling to that of a champion—the Vig-Row offers body-building principles never revealed to the public before because it is the only machine of its kind built by a man who understands muscle building. The Vig-Row is the perfect device for keeping fit and getting strong. Be sure to investigate the VIG-ROW!—You will agree that it is the greatest and most perfect rowing machine ever marketed, regardless of price. Its many features and beauty will amaze you—our slogan is "FACTS FIRST"—then the sale—send no money—write now for additional free information.

Examine VIG-ROW First

Space doesn't permit the entire story about the Vig-Row. It has too many real features. There are too many reasons why you should select the Vig-Row. We don't ask you to purchase from this advertisement—we do ask that you write for our large photographic circular so you can see and realize the difference yourself. Write for free facts now. Don't buy now from us or anyone else—compare—examine—test—don't buy a cat in the bag—write us now and get the wonderful complete Vig-Row story that brings you the reason why you will be proud to own a Vig-Row.

FREE Instructions

We don't think it enough to just sell you the finest rowing machine in the world and trust that you will use it and get strong. No! We furnish a course of instructions without extra cost, that are complete in every detail. Shows how to develop every part of the body with the Vig-Row—Prepared and written by a master of Physical Culture—and it's yours free, if you write at once.

Exclusive VIG-ROW Features

- 1 Inclined frame for true rowing motion
- 2 Rubber wheels, oilless bearings
- 3 Arch supporting foot
- 4 Rolling, form-fitting aluminum seat
- 5 Polished hardwood frame
- 6 Instantly adjustable progressive exercising, nickel steel springs
- 7 Platform for standing exercises.
- 8 Aluminum front
- 9 Double rollers
- 10 Ventilated handles



AMERICAN ATHLETIC APPLIANCE CO.,
239 Broadway, Dept. 2712, New York

Please send absolutely free and without obligation full details about your wonderful Vig-Row rowing machine. Also reserve one of those free instruction courses. I have checked plan of purchase that interests me, if I decide to purchase a Vig-Row.

Cash Price

Installment Plan

Name Age

Street

City State

Our Future Motive Power •

(Continued from page 28)

carefully worked out plan of this kind, supported by figures and estimates, was submitted by him to prominent capitalists and business men of New York about 50 years ago. He not only contemplated the production and distribution of power for general use but intended even to propel boats by energy derived in the same manner, using, preferably, ether as working fluid. On account of his death, or for other reasons, the project was not carried into practice.

Of this I learned much later when I interested in my alternating system Alfred S. Brown, a well known technical expert, called upon to examine the merits of my inventions, and C. F. Peck, a distinguished lawyer, who organized a company for their commercial introduction. These men were among the first approached by the engineer and considered his plan rational in principle, but the pipe lines, pumps, engines, boilers and condensers involved too great an outlay and, besides, a profitable disposal of the power was difficult and uncertain. My discovery of the rotating magnetic field brought about a change in the situation and in their attitude. They thought that if the energy could be economically transmitted to distant places by my system and the cost of the ocean plant substantially reduced, this inexhaustible source might be successfully exploited. Mr. Peck had influential connections, among them John C. Moore, the founder of the banking house bearing his name. With the exception of the late J. P. Morgan, who towered above all the Wall Street people like Samson over the Philistines, Moore was probably the strongest personality. I was given to understand that if I could evolve a plan satisfactory to Mr. Brown and other engineers, all the capital required for an enterprise on a very large scale, as contemplated by them, would be promptly furnished. No encouragement from my associates was needed for determining me to undertake the task, as the idea appeared, at first, wonderfully promising and attractive although there was nothing about it fundamentally new.

Undoubtedly, the essential conditions required to operate a steam or other thermodynamic engine could be fulfilled, a considerable temperature difference being available at all times. No proof had to be furnished that heat would flow from a higher to a lower level and could be transformed into mechanical work. Nor was it necessary to show that the surface water, although much below its normal boiling point of 212° F., can be readily converted into steam by subjecting it to a vacuum which causes ebullition at any temperature however low. It is of common knowledge that, due to this same effect, beans cannot be cooked or eggs hard-boiled on high mountains. Also, for a like reason turbines have been wrecked in steam power plants with the boilers completely shut off, the slightly warm water in the system of connecting pipes being evaporated under a high vacuum inadvertently applied. This behavior of water, or liquids in general, was long before beautifully exemplified in the classical device called "eryphoros" consisting of two communicating and exhausted bulbs partially filled with liquid, which is evaporated in one and condensed in the other. It was invented by W. H. Wollaston, a great English scientific man and investigator (1766-1828), who first commercialized platinum and was credited by some to have anticipated Faraday in the discovery of electromagnetic rotation. The original instrument brought out at the beginning of the nineteenth century had one of the bulbs packed in ice with the result of freezing water in the other. Conformably to the views of that time it was thought that the cold of the ice was carried to the water and so the Greek name, meaning "cold-carrier," was given to the device. But now

we know that the process is of opposite character, the freezing being brought about by the transport of the latent heat of evaporation from the warm to the cold bulb. One would naturally infer that the operation would cease as soon as the water is frozen at the surface, but curiously enough the ice itself continues to yield steam and it is only because of this that all of the water is solidified. We may imagine how puzzling this phenomenon appeared more than one century ago!

The ocean plant proposed by the engineer was nothing else but Wollaston's device of huge proportions, adapted for continuous operation and having an engine interposed between the two communicating vessels. In estimating its thermo-dynamic performance the first results I arrived at through the medium of pad and pencil fairly bewildered me. To illustrate by an example, suppose that equal quantities, say, one-half pound of the warm and of the cold water, respectively, at 82° and 32° Fahrenheit, are mixed or put in thermal equilibrium otherwise. The first will then give up to the second 12.5 heat units, mechanically equivalent to 97.5 foot pounds—the same energy which would be developed in the fall of one pound from so great an altitude as 97.5 feet. The dream of my life had been to harness Niagara, but here was a fall sixty times higher and of unlimited volume. To raise the cold water to the surface from any depth whatever, required but a trifling effort and as other losses also seemed negligible I concluded that if only a small portion of this hypothetical fall could be utilized, one of the greatest problems confronting humanity would be solved for all times to come.

I knew that it was too good to be true, nevertheless I followed this ignis fatuus for years until, little by little, through close reasoning, calculation and experiment, I got the true bearings in the swamp of my ignorance and doubt. Then this scheme of harnessing the ocean revealed itself to my mind as one of the crudest imaginable. Just to transport a little heat, water has to be pumped and disposed of in quantities so enormous that a large installation of this type would present new problems in engineering. Contrary to the opinion I had previously formed, this involved the expenditure of a great amount of energy. Then I realized that the gases contained in the water can be only partially extracted and have to be continuously removed from the condenser to prevent the rise of back pressure which might reduce the speed and eventually stop the engine.

Furthermore, due to certain conditions, the deep sea water must enter the pipe warmer than it should conformably to soundings, so that the full temperature difference cannot be obtained, and I discovered other peculiar causes which, after some time, might seriously interfere with the proper functioning of the mechanism. The steam, raised directly from the surface water, is of the poorest quality, mere mist under small pressure, and its consumption per horsepower hour was likely to be twenty times greater than in modern plants. In hydro-electric stations, as before stated, eighty-five per cent of the energy of falling water may be captured, while in this case hardly more than two-tenths of one per cent of the theoretical fall can be utilized. Worst of all, the size and cost of the equipment is utterly out of proportion to the greatest possible returns. These and other limitations and difficulties forced themselves upon me in studying the plans as first submitted.

The introduction of my alternating system started a scramble for the most valuable water power sites and no attempt was made to harness the ocean. But my interest was aroused to such a degree that

LOOK-FELLOWS-LOOK
Model Aviator-Featherweight Motor
 For Use on Model Planes and Model Boats

New rock bottom prices. **NOW ONLY 99 CENTS**
 All parts bent, formed, timed and drilled. Knock-down 3-cyl. Kit postpaid. Finished Motor postpaid, \$2.95
 Air Tank Kit, 3"x3"x30" or smaller Postpaid \$1.95.
 Tank Complete, ready to use, 3"x2 1/2" or 30" long. Postpaid \$4.95.

MODEL PLANE PLANS 10c
3 Plans for 25c

Stinson Monoplane, Traveler Mystery "S", S. E. 5 Pursuit, Lock-head Vega, Rocket Plane, Fokker Amphibian, Out Hydro Model A-31 Seaplane.

Roing P12-B—American. D-H Tiger Moth—English. Ansaldo—Italian. Gloster 325 M.P.E. Seaplane Bacter.

WATCH FOR 4 NEW PLANS EVERY MONTH CATALOGUE 10c

DEALERS: Write for Discount on Plans
MODEL AVIATOR PRODUCTS
 Dept. 99 3335 Eastwood Ave., Chicago

PROTECT YOUR LIFE with TEAR GAS FOUNTAIN PEN

Brand New Instant Protection without injury to anyone. Agents can make up to \$400.00 monthly. One agent sold 1 dozen in 6 hours. One minute demonstration gets the order every time. Sells on sight. Protection for everybody against robbers, criminals, morons, vicious dogs, etc. Every autoist, store, bank, theatre and every home prospect.

AGENTS: Grab This Money Maker
 Step into this new, unlimbed, money-making field. You take orders. Collect your big pay daily. Devote part or full time. Exclusive territory still open. Write quick for starting offer.

ATLAS CO., Chesterfield Station, Dept. 1812 Chicago

How To Obtain A Better Looking Nose

Improve Your Personal Appearance. My free book tells you how I guarantee to improve the shape of your nose by remodeling the cartilage and fleshy parts, quickly, safely, and painlessly, or refund your money. The very fine, precise adjustments which only my new patented Model 25 Nose Shaper possesses, make results satisfactory and lasting. Worn night or day. Over 100,000 users. Send for free book to **W. TRILEY, Plastic Nose Shaping Specialist, Dept. 295, Binghamton, N. Y.**

HIDDEN METALS

Such as Buried Treasure, Lost Oil Rig Equipment, etc., may now be accurately located by Radio and Electric Methods. Send Red Stamp today for full details—no obligation.

EXCHANGE, P. O. Box 607-M, El Monte California

Make PHOTOGRAPHY Your CAREER

This two billion dollar industry offers splendid opportunities as Motion Picture Camera man and Projectionist, "Still" Photographer and Photo Finisher. Easy to learn by our simplified method.

TODAY SEND FOR FREE BOOK giving full details. State which interests you.

NEW YORK INSTITUTE OF PHOTOGRAPHY - 10 West 23rd St. (Opp. 14 New York)

WANT A STEADY JOB?
 \$158 to \$225 month. Railway Postal Clerks. Many other Government jobs. Write IMMEDIATELY for free 32-page book with list of U. S. Gov't positions open to men and women, 18 to 50, and particulars telling how to get them.

FRANKLIN INSTITUTE
 Dept. K304 ROCHESTER, N. Y.

I continued the work and made a number of improvements which are thought to possess some merit. Satisfied that pipes supported by floats or hung in submarine abysses were impracticable, I proposed a sloping tunnel, lined with heat insulating cement, affording a smooth and unbroken passage for the deep sea water. I found ways of simplifying and cheapening the apparatus and making it more effective by reducing the moisture of the steam and otherwise, and these advances may eventually prove of practical value.

To conduce to a more ready understanding of the evolution of the ocean power plant from the cryophoros and of the nature of some of my improvements, reference may be made to the drawings in which Fig. 1 represents the original device of Wollaston, comprising two highly exhausted vessels B and C, respectively, the boiler and condenser, connected through a channel A. The first named vessel being partly filled with water or other liquid and the second packed in a freezing mixture, the vacuum causes the water when slightly warmed to boil furiously and the well known effect is observed. As the steam generated in the boiler rushes into the condenser with great speed, it is capable of producing a considerable mechanical effort.

Fig. 2 illustrates how the thermo-dynamic transformation of energy may be effected to obtain useful external work. This particular arrangement is chosen in order to dispense with the necessity of a connection to the outside which would call for the employment of a vacuum pump. A steel armature a, of a diameter nearly equal to that of the channel A, connecting vessels B and C, and shaped like a fan, is supported in virtually frictionless bearings b and c, of which the latter may be designed for taking up the thrust. Surrounding the armature, or turbine rotor, and in close proximity to the same, are soft-iron projections as d and e, wound with coils f and g and forming part of a permanent magnet h. The rapid rotation of the armature results in a periodic shifting of magnetic lines from one to the other set of projections, this including in the coils currents which may be utilized.

The next step is to adapt the device for continuous operation. This may be done in two ways: by supplying the evaporating and condensing water directly to the vessels B and C, or by merely transmitting and abstracting heat through their walls, in which case the working fluid is entirely separated and circulated in a closed circuit.

The first plan is diagrammatically shown in Fig. 3. The vessels B and C are cylinders joined by a turbine D through suitable pipe connections. A suction pump E, constructed for producing a very high vacuum, is attached to the condenser C and may be driven by the turbine through a gear or, as indicated, by an induction motor energized with alternating currents from the dynamo F coupled to the turbine. The water being under atmospheric pressure would flow into the evacuated vessels at too great a speed occasioning corresponding losses, and for this reason it is necessary to supply and drain it through balancing barometric columns l l and k k of proper height thereby insuring the desired circulation, the direction of which is indicated by arrows. Since the latent heat absorbed in evaporation and set free in condensation is very great, an immense quantity of water must be circulated through the vessels in order to prevent changes of temperature sufficient to seriously reduce the performance of the apparatus. In addition to the devices shown, separators must be employed for extracting gases from the water before its entrance into the boiler and condenser. These cannot be of the effective centrifugal type as they would entail too great a loss of energy. The only kind practicable is that used from the earliest beginnings of modern hydraulics, the action of which is based on a slow reversal of direction of flow and accomplishes only partial degasification. It should be noted that the gases,

by rapid expansion and attendant cooling, impair greatly the quality of the steam and also, more or less, the vacuum in the vessels. One of my improvements is to supply the water in the form of jets, as represented, which furnish the necessary evaporating and condensing surface while at the same time carrying away gases which would be liberated if the water were admitted as usual.

A careful study of the scheme illustrated in Fig. 3 has satisfied me that it is, for a number of reasons, disadvantageous and less practicable than that shown in Fig. 4. In this instance the vessels B and C are surface condensers of ordinary design but of very great active areas in view of the excessive steam consumption and small differences of temperature applied. They may be of the same size, for although the passage of heat from the hot to the cold water takes place through the steam, the law of mixtures is obeyed, the maximum transfer occurring when the quantities of both are equal. Were it not for that the performance might be appreciably improved by supplying the hot water, which has to pass only through short pipes, in greater quantity. The vessels are connected through a turbine D coupled to a generator F, as before, and besides the suction pump E a deep well pump G is employed to force the condensate into the boiler. The water should be sweet and thoroughly degasified yielding steam of good quality and greatly reducing the work of the pumps, and both boiler and condenser should be completely immersed in the circulating media to minimize the heat losses. The important practical advantages of this plan are that any suitable working fluids and units of very great capacity may be used.

Technical experts who may examine the merits of the ocean power scheme will be apt to dismiss lightly the loss of energy involved in the propulsion of the hot and cold water which in reality, may be very serious on account of the lift above the mean ocean level. The outlets are unavoidably very large and if their centers are from three to four feet above the mean level to insure normal functioning at high tide the pumping losses will be considerable. Furthermore, the water is subjected to repeated changes in direction and velocity and suffers a frictional loss of head, especially in the long conduit, all of which may be equivalent to an additional life of a few feet, making the total, say, 7 feet, conservatively estimated.

Now, in the Gulf of Mexico or in Cuban waters, where my associates intended to build plants, the temperature difference between the hot and cold water will be hardly more than 30° F. as an annual average, and with the poor steam obtainable the circulation may be as much as 12 lbs. of each per horse power per second. Consequently, the

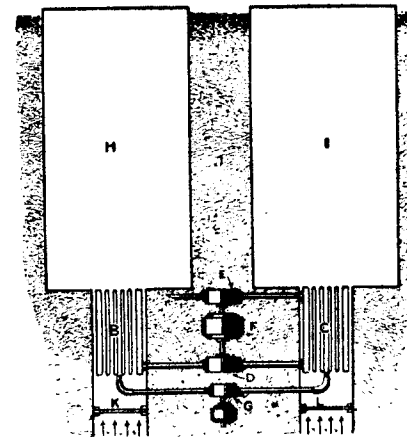

FIG. 5
 The basins H and I are filled and emptied by the tide, saving much of the energy otherwise expended in pumping.

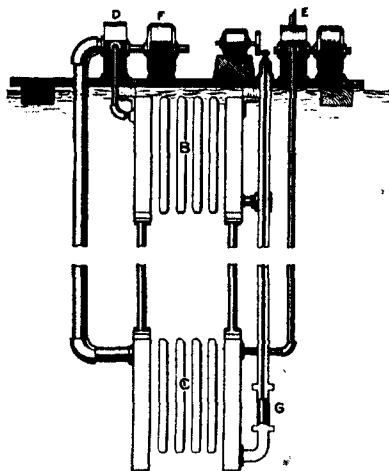

FIG. 6

A floating thermo-electric power plant, in which the condenser C is suspended beneath the boiler B and the condensate circulates vertically.

mechanical work may be estimated at 168 foot pounds per second and this figure must be almost doubled because the over-all efficiency of induction motor-driven pump units, which have to be employed, is not much above fifty per cent, as a rule. Since one horse power is a rate of 550 foot pounds per second this means a loss of about 40 per cent. Besides, the operation of the degasifiers, vacuum and deep well pumps, will consume energy which has to be supplied from the turbo-generator and taken at nearly twice its value for the reason pointed out. All these losses may be reduced in various ways but not to a very great extent, and the example clearly shows the desirability of doing away with them. This argument is applicable, even with greater force, to the cost of the pumping outfits of which I will endeavor to convey an idea by assuming that a 30,000 horse power plant is installed, requiring not less than 300,000 pounds of hot and of cold water per second, which means, approximately, 4,700 cubic feet of each. As a velocity of 3 feet per second should not be exceeded, two pumps capable of meeting the requirements would have intake and outlet openings of 1800 square feet, with the usual allowances. Evidently such monstrous machines could not be used, for one reason, not to mention others, that the lift would be very great and the loss incurred prohibitive. This brings to light a bad feature of the scheme illustrated in Fig. 3, namely, that it is impracticable to have recourse to very large units and thereby secure the customary advantages. A great number of small units must be of necessity used and it follows that the larger the plant the poorer it will be. Instead of the two pumps each with openings of 1800 square feet, at least one hundred motor-driven pumps with orifices of 36 square feet and a corresponding number of boilers and condensers with enormous inlet and outlet pipes would have to be employed, and at a staggering cost.

These and other similar considerations have prompted me to devise the plan schematically shown in Fig. 5 in which I do away entirely with the water pumps by relying wholly on ebb and tide to bring about the required circulation of the heating and cooling media, thus simplifying the plant and obviating great losses and expenditures. The installation comprises two very large basins lined with heat insulating cement designated by H and I and provided with suitable supports for heat-insulating roofs or covers the function of which is to minimize losses by radiation and influx of heat, respectively, from the hot and to the cold water. Each of the basins has a controllable opening, respectively K and L situated close to the bottom, where

also the boiler B and condenser C, are located. The latter are connected through a turbine D coupled to a generator F, constituting a unit of large capacity. As in the case before described, a suction pump E and a deep well pump G are provided, driven by induction motors energized from the generator. All this machinery is placed on a common foundation, as indicated. The basins are filled at high tide and the outflow during the period of ebb is controlled so as to secure the best results. Although the power is subject to periodic variations, the plant can be operated satisfactorily without the employment of batteries or other means of storage and thus the cost of this commodity may be greatly reduced.

Another way of deriving power from the temperature differences in the ocean without the use of water pumps is illustrated in Fig. 6. The apparatus comprises the same essential parts which have been already described, namely, a tubular boiler B and like condenser C connected through a turbine D driving a generator F, a high vacuum pump E and a small reciprocating deep-well pump G for lifting the condensate from the condenser into the boiler. The latter is supported in the warm surface water by a floating structure carrying all the machinery, while the former is suspended at a suitable depth in the cold water. Both of these parts are arranged with the tubes in vertical position insuring a good circulation of the heating and cooling media. This arrangement is very simple and effective but the raising of the condensate by pump G consumes considerable work. I have designed wireless power plants on this plan with practical objects in view and they may perhaps find valuable uses in the future.

Fig. 7 represents a partial view of a boat with apparatus for propelling it solely by the heat energy abstracted from the water. I was not informed just how the American engineer intended to propel his vessel and the scheme illustrated is my own. Two rotary pumps M and N are employed to force the warm and cold water, respectively, through the tubes of the boiler B and condenser C. This apparatus is placed slightly below the waterline for minimizing the losses involved in the circulation of the heating and cooling media. The pumps are supposed to be driven by induction motors, as illustrated, and are connected to the discharge pipes and other parts in such a way that the water cannot enter the hold of the vessel. The boiler intake O is near the ocean's surface while that of the condenser is at the requisite depth; a streamline shaped duct OI, open in front, being employed for the purpose. As the temperature of the water diminishes very rapidly through a limited distance from the surface of the ocean, sufficient energy can be abstracted from the water using a duct of fifty feet length to propel the boat by the streams escaping through the discharge pipes. No other means of propulsion is necessary and even the steering can be accomplished by suitably regulating the volume of the two streams discharged astern as shown. The turbine D, generator F, high vacuum pump E, deepwell pump G and other parts serve the same purposes as before. Some stored energy must be provided to start the vacuum pump and thereby initiate the operation of the apparatus.

The ocean power plan of the illustration on page 27 seems very inviting when considering that the energy obtained is proportionate to the quantity of the water pumped and, therefore, virtually unlimited. But it must be remembered that the true merit of such a scheme can only be measured by the returns. We have still greater and more readily available resources which are unused because they are unprofitable. On closer investigation many discouraging facts are unearthed. The deep sea water is, normally, at a low temperature but at any time a warm current of water may be produced and render the plant useless. It has been

(Continued on page 96)

NEW "Driver" MAGAZINE

10¢

FULL SIZE
BLUEPRINT
in every issue



In This Issue

AN END TABLE
BECOMES A
BRIDGE TABLE

Half-Hour Lath
Projects

How a Naval Engineer
Uses Driver Tools

What Driver Owners
Are Doing

The Old Timer Speaks

Questions and Answers

Child's Clothes Rack

Jig Saw Projects

Inlaying and Overlaying

New Things to Make

Homecrafting has developed to the stage where craftsmen deserve a magazine of their own, devoted exclusively to wood working.

Realizing this need, "Driver," the leading manufacturer in the field, has developed THE HOME CRAFTSMAN as that every workshop owner can derive keener satisfaction from his hobby and his equipment.

THE HOME CRAFTSMAN describes new things for you to make. New projects for the advanced craftsman. Simpler projects for the beginner. Shows you just how to start each job, gives all dimensions. Describes new tools. Tells how to inlay. Sponsors "Questions and Answers" column to solve your problems. Includes many other features. Has 24 pages of selected material. Edited at the work bench where every article described has been previously made. Full size blueprint in EVERY issue.

Send for this Issue

Complete Blueprint 17" x 22"

Get this first issue containing complete blueprint of unique Bridge Table-End Table. If unable to buy The Home Craftsman at your local "Driver" store, send coupon directly to us.

WALKER-TURNER CO., Inc.
Plainfield, N. J.

The HOME CRAFTSMAN Dept. S
Plainfield, N. J.

Editor: You may send me the first issue of your "Driver" Magazine, The Home Craftsman, containing complete blueprint 17" x 22" of the Bridge Table-End Table. I am enclosing 10 cents.

Name and address

• Index to Advertisers •

A	
American Athletic Appliance Co.	78
American School	3
Atlas Company	80
Auburn Automobile Company	Back cover
Audel & Company, Theo.	79
B	
B & L Engineering Company	95
Barbasol Company, The	Inside Back Cover
Benner & Company	93
C	
Capitol Radio Engineering Inst.....	91
Chemical Institute of N. Y. Inc.....	86
Classified Section	6
Coyne Electric School	5, 97
Culver Sales Company	Inside Front Cover
Cutting, T. A.	95
D	
Delta Specialty Company	73
E	
Electric R. & S. Co.	95
Evans & Co., Victor	77
Exchange	80
F	
Franklin Institute	80
G	
Gernsback Publications, Inc.....	82, 88, 94
Gernsback Corp., S.	84
H	
High School Home Study Bureau.....	93
Hotel Graham	93
K	
Keeley Institute	90
Kelsey Company	93
L	
Lancaster, Allwine & Rommel	74
LaSalle Extension University	85
Loftis Bros. & Company	91
M	
McGraw-Hill Book Company	83
Metal Cast Products Company.....	85
Model Aviator Products	80
N	
National Radio Institute	98
National Salesmen's Training Assoc.	87
New Method Mfg. Company	95
New York Institute of Photography.....	80
Norley Book Company	76
North American Institute	8
O	
Clarence A. O'Brien	75
P	
Polachek, Z. H.	74
Popular Book Corporation	90
Popular Homecraft	92
R	
Radio & Television Institute	7
Radio Trading Company	82
Randolph & Company	74
Roth Press	95
S	
Schiercke, Henry C.	95
Standard Business Training Inst.....	95
T	
Trilety, M.	80
U	
U. S. School of Music	89
W	
Walker-Turner Company	81
Wilson Chemical Company	93
Winsholt Sales Company	95
Y	
York Tire & Rubber Company.....	93

(While every precaution is taken to insure accuracy, we cannot guarantee against the possibility of an occasional change or omission in the preparation of this index.)

• Hearing Radio Without a Loud Speaker •

(Continued from page 59)

even more, with music. The sounding body, corresponding to the diaphragm of the speaker, and giving out vibrations to the air, is a piece of ordinary brass tubing, such as curtain rod, 20 to 40 inches long and, say, 1¼ inches in diameter, so that it affords a good grip. The walls are thin, 1/48-inch. The rod has insulators over its ends, and clips are attached to the metal. The speaker terminal (positive) of an A. F. amplifier is connected to one end of the tube; and the operator touches the negative terminal and rubs his fingers over the tube. *Both electrode*

and fingers must be dry! It is possible to transmit the impulse through two or even more individuals. The investigator reports that the hand rubbing over the metal seems to stick to it; and that the vibration of the tube is manifested by dust arising from its surface.

Considerable encouragement for the deaf is held up by experiments of the type in the lowest photograph. German physicians have found that electric currents produce "hearing" in the deaf and increased range of audible pitches in the hard-of-hearing.—*Die Umschau.*

• Our Future Motive Power •

(Continued from page 81)

observed that there may be differences of 35° F. or even more in the temperature of water at the same depth. Just as convection currents occur in the air so they may also be produced in the ocean and this is an ever present menace to an undertaking of this kind. It also appears the actually obtainable temperature difference must be always appreciably smaller than might be inferred from soundings. The raising of the denser water below a certain *niveau* into the less dense above it involves a performance of work which must be done by the pump but is not lost as the volume of the water discharged at the top of the deep-sea duct is correspondingly increased. This does not hold true of the water above the *niveau* and, consequently, the flow into the intake of the duct takes place preponderatingly from above, that is, in the direction of the downward convection current. Owing to this, warm water from above enters the intake thus reducing the temperature difference. Another curious fact cannot be ignored. The sea is densely populated with organisms which are subject to changes caused by age. As they grow older the life stream deposits more and more solid matter, they become specifically heavier and sink gradually until finally at great depths life is extinct. If this floating matter could be removed by the pump at a constant rate, as the water, it would give relatively little trouble. But as water is removed the concentration of this matter continuously increases and may become so great as to interfere seriously with the operation of the plant. Impairment of performance, if not interruption, might also be brought about by rust and deposits in the pipes, loosening of joints and other mishaps and for this reason I consider a tunnel as the practicable means for transporting the cold water.

I have studied this plan of power production from all angles and have devised apparatus for bringing down all losses to what I might call the irreducible minimum and still I find the performance too small to enable successful competition with the present methods.

The utilization of temperature differences in the solid earth presents several important advantages. It would make it unnecessary to go to the tropics where power is of smaller value. Indeed, the colder the climate the better. A shaft could be sunk in the midst of a densely populated district and a great saving effected in the cost of distribution. The shaft would be costly, of course, but the apparatus cheap, simple and efficient. The first drawing, on page 26, illustrates its essential parts comprising a boiler at a great depth, a condenser, cooled by river or other water available, on the ground, a turbine coupled to a generator, and a motor-driven high vacuum pump. The steam or vapor generated in the boiler is conveyed to the turbine and condenser

through an insulated central pipe while another smaller pipe, likewise provided with an *adiathermanous* covering serves to feed the condensate into the boiler by gravity. All that is necessary to open up unlimited resources of power throughout the world is to find some economic and speedy way of sinking deep shafts.

* * * * *

Whether we shall have to rely on power derived from terrestrial heat must be left to the future. If we should exhaust our present resources without opening up new ones, this possibility might arise. Undoubtedly, our stores of coal and oil will be eventually used up and there is not enough water power to supply our needs. The idea of obtaining motive energy from atoms or change of elements is unscientific and illusory and cannot be condemned too emphatically. The same is true of the scheme of harnessing the energy supposed to be liberated at such temperatures as 40,000,000 degrees C (Centigrade) recently suggested. The fundamental fallacy in all these proposals is that it takes more energy to disintegrate than can be usefully recovered even in an ideal process.

Gloriously fallacious theories are responsible for such chimerical hopes. Probably the worst of these is the electron theory. Of the four or five atomic structures which have been suggested not a single one is possible. Not more than one in a thousand men of science knows that an electron—whatever it be—can only exist in the perfect vacuum of intermolecular and interstellar spaces or highly exhausted tubes and that the nucleus stripped of electrons, is devoid of energy.

It was clear to me many years ago that a new and better source of power had to be discovered to meet the ever increasing demands of mankind. In a lecture delivered before the American Institute of Electrical Engineers at Columbia University May 20, 1891, I said: "We are whirling through endless space with inconceivable speed, all around us everything is spinning, everything is moving, everywhere is energy. There must be some way of availing ourselves of this energy more directly. Then, with the light obtained from the medium, with the power derived from it, with every form of energy obtained without effort, from the store forever inexhaustible, humanity will advance with giant strides."

I have thought and worked with this object in view unremittingly and am glad to say that I have sufficient theoretical and experimental evidence to fill me with hope, not to say confidence, that my efforts of years will be rewarded and that we shall have at our disposal a new source of power, superior even to the hydro-electric, which may be obtained by means of simple apparatus everywhere and in almost constant and unlimited amount.

New York Times
Feb. 6, 1932, P. 16, col. 8

DR. TESLA WRITES OF VARIOUS PHASES OF HIS DISCOVERY.

To the Editor of The New York Times:

You have given considerable space to the subject of cosmic rays, which seems to have aroused general attention to an unusual degree. Inasmuch as I discovered this wonderful phenomenon and investigated it long before others began their researches, your readers may perhaps be interested in my own findings.

The original idea was advanced and discussed by me in a series of articles on Röntgen rays and radioactivity, published from 1896 to 1898 in *The Electrical Review*. The results of my discoveries were reported all over the world through the Associated Press and found a powerful echo. But at that time scientific men were emphatically opposed to my theories, holding that the new actions were due to some kind of wave motion, while, according to my observations, they were produced by electrified particles of matter projected with great velocity. It was only years later that the views I then propounded were gradually accepted.

The experiments I undertook in 1896 were greatly facilitated through my invention of a novel form of vacuum tube suitable for operation by currents of many millions of volts and yielding effects of transcending intensities. This instrument has since been adopted by other investigators and most of the progress in several fields was achieved by its use.

When radioactivity was discovered, it was thought to be an entirely new manifestation of energy limited to a few substances. I obtained sufficient evidence to convince me that such actions were general and in nature the same as those exhibited by my tubes. In these, minute corpuscles, regarding which we are still in doubt, are shot from a highly electrified terminal against a target where they generate Röntgen or other rays by impact. Now, according to my theory, a radioactive body is simply a target which is continuously bombarded by infinitesimal bullets projected from all parts of the universe, and if this, then unknown, cosmic radiation could be wholly intercepted, radioactivity would cease.

I made some progress in solving the mystery until in 1899 I obtained mathematical and experimental proofs that the sun and other heavenly bodies similarly conditioned emit rays of great energy which consist of inconceivably small particles animated by velocities vastly exceeding that of light. So great is the penetrative power of these rays that they can traverse thousands of miles of solid matter with but slight diminution of velocity. In passing through space, which is filled with cosmic dust, they generated a secondary radiation of constant intensity, day and night, and pouring upon the earth equally from all directions. As the primary rays projected from the suns and stars can pass through distances measured in light-years without great diminution of velocity, it follows that whether a secondary ray is generated near a sun or at any distance from it, however great, its intensity is the same. Consequently, if our sun, or any other, would be snuffed out of existence, it would have no appreciable effect on the secondary radiation. The latter is not very penetrative and is partly absorbed by the atmosphere. According to my determinations, its intensity beyond the atmosphere is about 50 per cent greater than at sea level. The whole atmosphere being equivalent to about 36 inches of lead, it is easy to determine the intensity of this radiation by making a measurement of the penetration at any known altitude. This theory is borne out strikingly in experiments with my vacuum tubes, but even if I did not have such proofs I would consider it plausible.

While the exploration of the upper regions of the atmosphere may yield many important results in other fields, I do not think that it will contribute considerably

to our knowledge of the cosmic rays. In view of this, I believe that we will make much more rapid progress if those who are now taking interest in it will accept my theory and build further on this foundation, instead of embarking on useless errands in quest of mythical rays coming from nowhere.

Nikola Tesla
New York, Feb. 4, 1932

The following is Tesla's statement relating to force and matter, to Einstein's theories, and Tesla's own theory of gravitation. Courtesy of Nikola Tesla Papers, Rare Book and Manuscript Library, Columbia University.

We read a great deal about matter being changed into force and force being changed into matter by the cosmic rays. This is absurd. It is the same as saying that the body can be changed into the mind, and the mind into the body. We know that the mind is a functioning of the body, and in the same manner force is a function of matter. Without the body there can be no mind, without matter there can be no force.

Einstein has for years developed formulas explaining the mechanism of the cosmos. In doing this he overlooked an important factor, namely the fact that some of the heavenly bodies are increasing in distance from the sun. This is the same as writing a business letter and forgetting the subject you wish to write about. In order to explain this phenomenon Einstein has invented the quantity "lambda".

My theory of gravitation explains this phenomenon perfectly.

N. T.

April 15, 1932

New York World Telegram
Aug. 10, 1932

CHEWING GUM MORE FATAL THAN RUM, SAYS TESLA - by Nikola Tesla

(Nikola Tesla, dean of inventors at 76 and pioneer of radio, believes it is essential for the welfare of the country that prohibition end soon. In this article, which he wrote for the World-Telegram, he expresses somewhat unusual arguments against it.)

Much has been said about prohibition and its disastrous consequences, but the sheer folly and perniciousness of this measure cannot be fully appreciated until it is considered from the scientific point of view. It then appears not only unsound in principle but utterly devoid of validity.

Chiefly as a result of dry propoganda people have been led to believe that alcoholic beverages cause serious injuries to mind and body, while other stimulants, as tea and coffee, are almost harmless. I know from careful observation and life-long experience that the reverse is more nearly true.

Beginning with the enactment of the Volstead law I have been a moderate consumer of alcohol and it never hurt me in the least. On the contrary it helped me many times effectively over the peak of the effort.

It is in striking contrast in its medicinal and dietetic value to all other stimulants which, without exception, are injurious. Even smoking, snuffing or chewing tobacco will eventually impair the health, though not quite so much as chewing gum, which, by exhaustion of the salivary glands, puts many a foolish victim into an early grave.

But by far the greatest number of victims are claimed by tea and coffee. Dr. Alexander Haig, foremost authority on uric acid and founder of his famous diet, says of the former: - "Tea drinking is just like drug taking, in fact, and has just as terrible and fatal results."

Women, in particular, should shun tea as it is a means of committing beauty suicide. In this respect coffee is the very opposite, imparting sometimes to the face a fascinating aristocratic pallor.

I have read books and articles depicting the horrible effect of alcohol on human beings, but always found that the few individuals under observations were either hopeless drunkards or had been weakened by heredity and environment. Obviously every form of excess is injurious. Such an investigation, to be of value, should be limited to moderate drinkers who number in legions and experience no ill effects. They are, as a rule, long lived and considered by life insurance companies the safest policy holders.

Alcohol is not a poison, nor is it a drug. It is not classed as a poison in books on chemistry.

The truth about alcohol is that it acts as a caustic and a solvent. In small quantities it cleans and sterilizes the alimentary channels, thereby preventing infections, and proves a beneficial stimulant to thought, speech and physical exertion.

Alcohol is produced in the normal chemical reactions of the stomach and can be found in every part of the body, even in the brain of a total abstainer.

It is formed, not as a toxic inimical to life, but as a substance indispensable to vital processes.

To illustrate prohibitions's utter folly and danger it is only necessary to point out that a sudden change of diet or the omission of an essential element, especially

in advanced years, may induce high blood pressures, cause malnutrition or otherwise imperil life. When the Volstead act became a law I realized that, accustomed as I was to alcohol, it would be very difficult for me to break off. Only a few days of abstinence made me a very sick man and my health became precarious. Finally, after several months of suffering, little by little I gained and ever since have been a total abstainer.

If an attempt is made to enforce such a law as prohibition and thereby subject a citizen to suffering, danger and possible loss of life he or his relatives should be entitled to substantial reparation and these suits once begun would soon exhaust the treasury.

The Volstead act put the country into panic and unprecedented distress. This is but an unavoidable result of depriving the nation of a revenue of about \$200,000,000 a year and compelling it besides to pay to bootleggers nearly twice that sum annually. The tyrannical rule is killing business in some of its most important departments. The hotels and similar institutions are being rapidly forced to the wall.

I remember that in Austria a law compelled every community to keep fires going in the streets during an epidemic of cholera.

In the seventies when I myself contracted the disease all the streets of the city were filled with smoke and stench. Nevertheless the inhabitants died in heaps. It was passed by legislators unacquainted with vital facts of life out of their own sphere. In imposing this measure the legislative bodies have evidently exceeded their authority. Under such circumstance I fail to see why a repeal should be required. Nothing more need be done than to forget the law and so permit it to pass to a state of innocuous desuetude.

New York Herald Tribune
Sept. 11, 1932

PIONEER RADIO ENGINEER 'GIVES VIEWS ON POWER

Tesla Says Wireless Waves Are Not Electromagnetic, But Sound In Nature

Holds Space Not Curved

Predicts Power Transmission to Other Planets

by Nikola Tesla

The assumption of the Maxwellian ether was thought necessary to explain the propagation of light by transverse vibrations, which can only occur in a solid. So fascinating was this theory that even at present it has many supporters, despite the manifest impossibility of a medium, perfectly mobile and tenuous to a degree inconceivable, and yet extremely rigid, like steel. As a result some illusionary ideas have been formed and various phenomena erroneously interpreted. The so-called Hertz waves are still considered a reality proving that light is electrical in its nature, and also that the ether is capable of transmitting transverse vibrations of frequencies however low. This view has become untenable since I showed that the universal medium is a gaseous body in which only longitudinal pulses can be propagated, involving alternating compressions and expansions similar to those produced by sound waves in the air. Thus, a wireless transmitter does not emit Hertz waves which are a myth, but sound waves in the ether, behaving in every respect like those in the air, except that, owing to the great elastic force and extremely small density of the medium, their speed is that of light.

Suggested Short Waves Early

Since waves of this kind are all the more penetrating, the shorter they are, I have urged the experts engaged in the commercial application of the wireless art to employ very short waves, but for a long time my suggestions were not heeded. Eventually, though, this was done, and gradually the wave lengths were reduced to but a few meters. Invariably it was found that these waves, just as those in the air, follow the curvature of the earth and bend around obstacles, a peculiarity exhibited to a much lesser degree by transverse vibrations in a solid. Recently, however, ultrashort waves have been experimented with and the fact that they also have the same property was hailed as a great discovery, offering the stupendous promise to make wireless transmission infinitely simpler and cheaper.

It is of interest to know what wireless experts have expected, knowing that waves a few meters long are transmitted clear to the antipodes. Is there any reason that they would behave radically different when their length is reduced to about half of one meter?

Waves Go Around World.

As the general knowledge of this subject seems very limited, I may state, that even waves only one or two millimeters long, which I produced thirty-three years ago, provided that they carry sufficient energy, can be transmitted around the globe. This is not so much due to refraction and reflection as to the properties of a gaseous medium and certain peculiar action which I shall explain some time in the future. At present it may be sufficient to call attention to an important fact in this connection, namely, that this bending of the beam projected from reflector does not affect in the least its behavior in other respects. As regards deflection in a horizontal plane, it acts just as though it were straight. To be explicit the horizontal deviations are comparatively slight. In a proposed ultrashort wave transmission, the vertical bending, far from being an advantage, is a serious drawback, as it increased greatly the liability of disturbances by obstacles at the earth's surface. The downward deflection always occurs, irrespective of wave length, and also if the beam is thrown upward at an angle to the horizontal, and this tendency is, according to my finding, all the more pronounced the bigger the planet. On a body as large as the sun, it would be impossible to project a disturbance of this kind to any considerable distance except along the surface.

It might be inferred that I am alluding to the curvature of space supposed to exist according to the teachings of relativity, but nothing could be further from my mind. I hold that space cannot be curved, for the simple reason that it can have no properties. It might as well be said that God has properties. He has not, but only attributes and these are of our own making. Of properties we can only speak when dealing with matter filling the space. To say that in the presence of large bodies space becomes curved, is equivalent to stating that something can act upon nothing. I, for one, refuse to subscribe to such a view.

Need Radio Channels.

The chief object of employing very short waves is to provide an increased number of channels required to satisfy the ever-growing demand for wireless appliances. But this is only because the transmitting and receiving apparatus, as generally employed, is ill-conceived and not well adapted for selection. The transmitter generates several systems of waves, all of which, except one, are useless. As a consequence, only an infinitesimal amount of energy reaches the receiver and dependence is placed on extreme amplification, which can be easily affected by the use of the so-called three-electrode tubes. This invention has been credited to others, but as a matter of fact, it was brought out by me in 1892, the principle being described and illustrated in my lecture before the Franklin Institute and

National Electric Light Association. In my original device I put around the incandescent filament a conducting member, which I called a "sieve." This device is connected to a wire leading outside of the bulb and serves to modify the stream of particles projected from the filament according to the charge imparted to it. In this manner a new kind of detector, rectifier and amplifier was provided. Many forms of tubes on this principle were constructed by me and various interesting effects obtained by their means shown to visitors in my laboratory from 1893 to 1899, when I undertook the erection of an experimental world-system wireless plant at Colorado Springs.

During the last thirty-two years these tubes have been made veritable marvels of mechanical perfection, but while helpful in many ways they have drawn the experts away from the simpler and much superior arrangement which I attempted to introduce in 1901. My plans involved the use of a highly effective and efficient transmitter conveying to any receiver at whatever distance, a relatively large amount of energy. The receiver is itself a device of elementary simplicity partaking of the characteristics of the ear, except that it is immensely more sensitive. In such a system resonant amplification is the only one necessary and the selectivity is so great that any desired number of separate channels can be provided without going to waves shorter than a few meters.

For this reason, and because of other shortcomings, I do not attach much importance to the employment of waves which are now being experimented with. Besides, I am contemplating the practical use of another principle, which I have discovered and which is almost unlimited in the number of channels and in the energy three-electrode tubes. This invention has been credited to others, but as a matter of fact, it was brought out by me in 1892, the principle being transmitted. It should enable us to obtain many important results heretofore considered impossible. With the knowledge of the facts before me, I do not think it hazardous to predict that we will be enabled to illuminate the whole sky at night and that eventually we will flash power in virtually unlimited amounts to planets. It would not surprise me at all if an experiment to transmit thousands of horsepower to the moon by this new method were made in a few years from now.

N. Y. Evening Post
June 5, 1933

MR. TESLA WRITES

To the Editor of the Evening Post:

Sir - Many of your readers, like myself, will feel indebted to you for your courageous and telling editorials relating to the investigation of the affairs of J. P. Morgan & Co. You have condemned these unfair proceedings in terms none too strong. Their undignified character is brought into evidence more and more, and it is becoming apparent even to the dullest observer that the honor and reputation of this famous banking house is resting on a foundation as solid as the Rock of Gibraltar. Perhaps it is fortunate that this investigation has been pushed so far, for in these times when confidence is most needed, the Morgans, in meeting these attacks, may be rendering the country service of inestimable value.

The general public has not even a remote idea of the position of this firm as a factor in the development of America. More than any other force, they were instrumental in the furtherance of American interests throughout the world and in the building up of this country's power and prestige. Scores and scores of vast enterprises could not have been carried out but for their financial assistance. They helped Edison in commercializing his inventions and contributed to my own scientific researches with princely generosity. Edison and myself were only two among hundreds of inventors, engineers, artists and scientific men whose work they made possible. They advanced capital when all other doors were closed, stabilized the markets and fought depressions, not half-heartedly like others but with all their energies and resources, and at a peril to themselves. What they have added to national wealth staggers imagination.

I was intimately acquainted with the founder of this great house and know that his spirit is still with his successors. He set the example and they are endeavoring to emulate him with almost religious fervor. Persons worthy of respect can be found everywhere, but I have observed in the House of Morgan a largeness, nobility and firmness of character the like of which is very scarce indeed.

I can only smile when I read of the attempts to find something discreditable in the transactions of J. P. Morgan & Co. Not a hundred of such investigations will ever uncover anything which an unprejudiced judge would not consider strictly honorable, fair, decent and in every way conforming to the high ideals and ethical standards of business. I would be willing to stake my life on it.

NIKOLA TESLA.

New York, June 2, 1933.

Breaking Up Tornadoes

By NIKOLA TESLA



NIKOLA TESLA

EVERY year whirling tornadoes cause great damage in the United States; and this disaster, like earthquakes, has hitherto been accepted as unavoidable. But the great scientist and inventor, Nikola Tesla, who has given the matter special study, both experimentally and theoretically, here proposes a practicable plan for the organization of a national government service to combat and break up tornadoes, when forming; just as a fire department responds to an alarm and overwhelms the blaze while it is still small. It is to be hoped that this proposal will be met by official investigation and adequate action at Washington.—EDITOR.

● MANY reports of tidal air waves, cyclones, and especially of tornadoes describe actions which are unbelievable; and to account for them some observers have assumed velocities of the order of those attained in explosives.

Just to get an idea, suppose that one pound of dynamite occupying the whole volume of its container is ignited. The maximum theoretical velocity (See Note A at end of article for calculation) attained in a perfect nozzle is 11,400 feet per second, which is obviously far above that actually attained at the mouth. In such an explosion, however, the gases are projected through a hemispherical opening of great area with correspondingly smaller speed, which is further reduced in accelerating the free air. Thus, at a small distance from the center of the disturbance, the tidal wave advances with the speed of sound; that is, 1089 feet per second.

I have had many opportunities for checking this value by observation of explosions and lightning discharges. An ideal case of this kind presented itself at Colorado Springs in July, 1899, while I was

EXPLOSIVE-LOADED PLANE EXPLODED IN TORNADO TO BREAK UP WHIRL

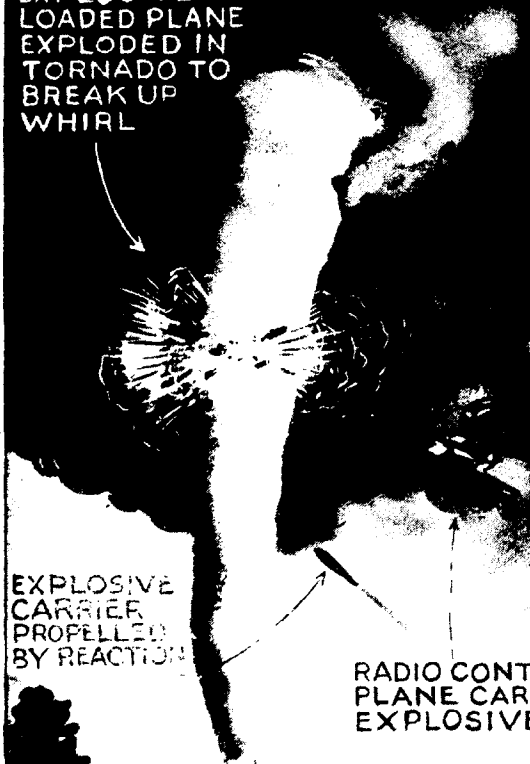

EXPLOSIVE CARRIER PROPELLED BY REACTION

RADIO CONTROLLED PLANE CARRYING EXPLOSIVE



SAILORS SHOOTING AT WATERSPOUT WITH CANNON



HANGAR HOUSING TORNADO DESTROYING PLANES

OBSERVER

TOWER FOR TRANSMISSION OF ENERGY AND CONTROL OF THE DEVICE CARRYING EXPLOSIVE

The old idea of shooting at a waterspout was correct in principle, but insufficient in force. Yet, as calculated here, the force of a tornado can be overcome by modern explosives, which might be efficiently and safely applied as shown.

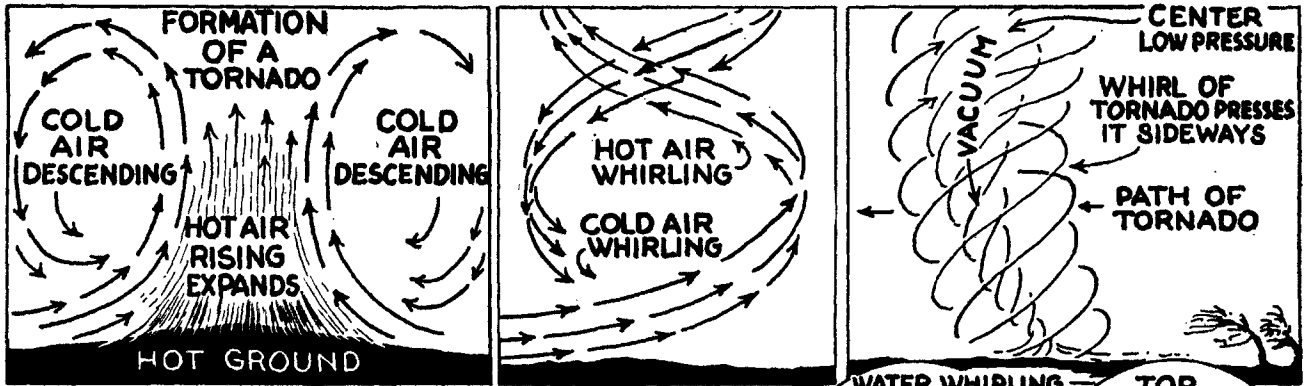

carrying on tests with my broadcasting power station (which was the only wireless plant in existence at that time). A heavy cloud had gathered over Pike's Peak range, and suddenly lightning struck at a point just ten miles away. I timed the flash instantly and, upon making a quick computation, told my assistants that the tidal wave would arrive in 48½ seconds. With exactly the lapse of this time interval, a terrific blow struck the building, which might have been thrown off the foundations had it not been strongly braced. All the windows on the exposed side and a door were demolished, and much damage was done in the interior. Taking into account the energy of the electric discharge and its duration, as well as that of an explosion, I estimated that the concussion was about equivalent to that which might have been produced by the ignition of twelve tons of dynamite. Though the mechanical effects of lightning bolts diminish with the square of the distance, they are still plainly observable within the range of six hundred miles.

It should be borne in mind that these actions are of very small duration, and that a steady gale of such velocity would produce appalling effects. It would quickly erode and grind up the hardest materials, fuse metals by friction and impact and burn up anything that is combustible. Objects, no matter how large and heavy, would be carried off like feathers, and even a mountain range could not resist for any considerable period of time; since

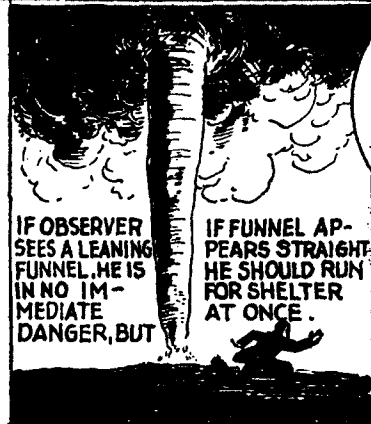

the pressure on an area normal (perpendicular) to the direction of the air blast would be close to three thousand pounds per square foot. Certainly, the inhabitants of this globe have reasons to congratulate themselves that such storms are impossible. Tornadoes, such as actually occur, are bad enough.

The fact is that relatively very small velocities of the wind are quite capable of producing the actions noted even though they may appear astonishing and puzzling at first thought. To illustrate, consider the mechanical effect of a stalk of dry grass or straw hurled normally against a wooden plank with a speed of only 150 feet per

(Continued on page 905)

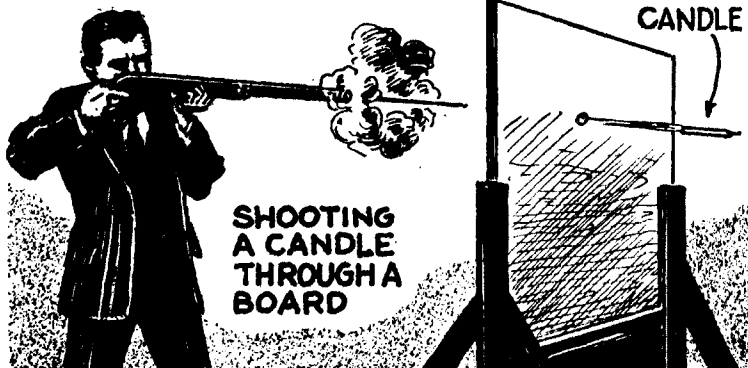
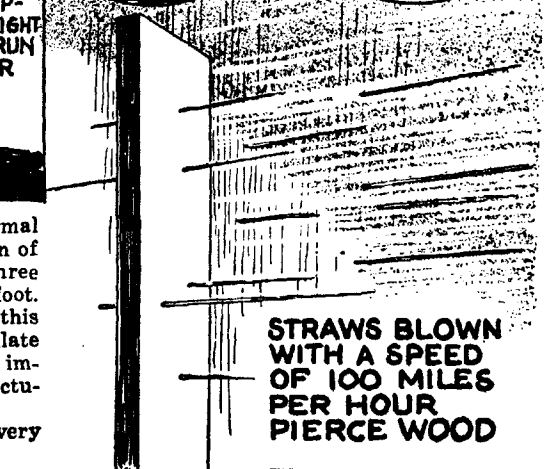
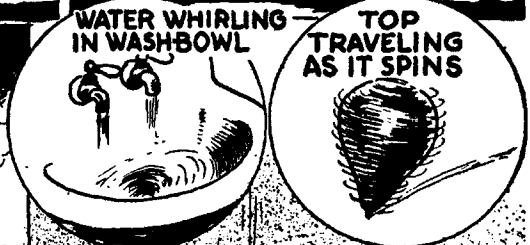

The formation of a tornado is shown above; it spins, as do the waste water and the top. Its tremendous velocity of rotation enables it to accomplish many of the freak results shown; just as when the soft candle is shot undamaged through a hard board.

Breaking Up Tornadoes

(Continued from page 871)

second. (See Note B) The force of 2929.5 pounds per square inch is much more than the plank can withstand; the compressive strength of oak perpendicular to the grain being less than half of that. Evidently, then, an effect of this kind can be surely expected even with much smaller speed, especially if the stalk is pointed.

In this connection it is of interest to mention a classical experiment, which used to be shown to students in some European institutions of learning. It consisted in firing from a gun a tallow or stearin candle at a board 0.4-inch thick. To the amazement of the onlookers, the soft missile not only went through the wood but did not appear much worse for the experience. The secret of success was in the quickness of the transit, not giving enough time for the mass of the candle to yield. The obvious inference from such action is that an exposure to a windstorm is always fraught with danger to life; for bits of flying material, not excluding pieces of straw, may penetrate deeply into the flesh. If my memory serves me right, I have read of serious accidents of this sort.

But the highest air velocities observed in storms are not, in themselves, adequate to explain certain stupendous performances of the wind, such as lifting loaded cars and locomotives and hurling them to great distance. When I first read such reports, many years ago, they afforded me amusement as I took them for original American canards, often sprung on unsophisticated foreigners. When I found, to my unspeakable astonishment, that they were substantially true I endeavored again and again to prove them by theories and calculations; but it was only lately that I solved this long-standing riddle.

Whirling movements of the atmosphere have been known and dreaded since time immemorial, but, beyond accounts of their destructive actions, mostly uncertain, little positive information can be found about them. In 1862 was published by H. W. Dove an important work, entitled "The Law of Storms"; dealing chiefly with cyclones, which frequently extend over a large portion of the globe and travel thousands of miles before their energy is spent. These are easily studied and the chief facts concerning them are now well known. Not so the incomparably more dangerous local storms, the real tornadoes, which are sudden, erratic, ephemeral (short-lived) and extremely violent manifestations difficult to investigate.

Of late years the U. S. Weather Bureau and the Smithsonian Institution have been supplying data which are reliable and of value in connection with the subject; nevertheless, our knowledge of tornadoes is still fragmentary. Ignoring newspaper reports, which are not quite reliable, and confining myself to facts unmistakably established, I have come to certain conclusions regarding these phenomena, which might be important, and can be summarized as follows:

(1) The maximum velocity of the air forming the funnel probably never exceeds, say, 235 feet per second or about 160 miles an hour; which I think ample to explain all the actions observed. In his "Manual of Meteorology," an exhaustive treatise lately published, Sir William Napier Shaw makes the state-

(Continued on page 920)

Learn at Home to Make More Money

I'll train You Quickly for Radio's GOOD spare time and full time Jobs . . .



J. E. Smith, President, National Radio Institute, the man who has directed the Home-Study training of more men for the Radio Industry than any other man in America.



Jobs in Broadcasting Stations are fascinating, interesting, and pay well.



Set servicing has paid many N. R. I. men \$200 to \$1,000 a year for their spare time. Full-time men make as much as \$40, \$60, \$75 a week.

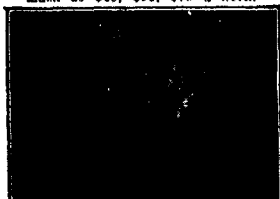

Television, the coming field of great opportunities, is covered in my Course.

Some Other Jobs N.R.I. Trains Men For

- Broadcast Engineer.
- Operator in Broadcast Station.
- Aircraft Radio Operator.
- Operator of Airway Beacons.
- Government Radio Operator.
- Ship Operator.
- Serviceman on Loud Speaker Systems.
- Installation Engineer on Loud Speaker Systems.
- Sales Manager for Retail Stores.
- Service Manager for Retail Stores.
- Auto Radio Installation and Serviceman.
- Television Broadcast Operator.
- Television Engineer.
- Set Servicing Expert.

MAIL THIS NOW for FREE book

Why slave your life away in a no-future job? Why skimp, why scrape trying to pay your bills? I'll train you quickly for the live-wire field—the field with a future—**RADIO**. \$40, \$60, \$75 a week—that's what many Radio Experts make, \$5, \$10, \$15 a week extra money—that's what many of my students make in their spare time shortly after enrolling. My free books tells you about Radio's spare-time and full-time opportunities—about my tested training—about my students and graduates—what they are doing and making. Get this book. Be a Radio Expert. The Radio field is big enough to absorb many more properly trained men.

I'll train you for jobs like these

Spare-time and full-time Radio Servicing, Operating Broadcast, Aircraft Radio, Commercial Land, Ship, and Television stations, a Radio service business of your own. I'll train you for these and other good jobs in the manufacture, sale, and service of Radio and Television apparatus. My FREE book tells you about the many money-making opportunities in Radio.

Save—learn at home in your spare time

You don't have to leave home and spend \$500 to \$1,000 to study Radio. I'll train you quickly and inexpensively right in your own home and in your spare time for a good Radio job. You don't need a high school or college education. Many of my successful graduates didn't even finish grade school. My amazingly practical 50-50 method of training—right with lessons, half with Radio equipment—gives you broad practical experience—makes learning at home easy, fascinating, practical, and rapid.

Many make \$5, \$10, \$15 a week extra in spare time almost at once

My book shows how my special training, instruction material, plans, ideas and my nineteen years' experience training men for Radio careers have helped many students make \$200 to \$1,000 a year quickly in their spare time. My Course is famous as "the one that pays for itself."

Your money back if not satisfied

I'm so sure you will be satisfied with my training that I agree in writing to refund every penny of your money if you are not entirely satisfied with my Lessons and Instruction Service when you finish.

Find out what Radio offers you

Act today. Mail the coupon. My 64-page book will be sent free to any ambitious fellow over 15 years of age. It tells about Radio's opportunities—explains the eighteen star features of my Course—shows letters of what others are doing and making. There is no obligation. Mail the coupon.

J. E. SMITH, President
National Radio Institute
Department 3NC
Washington, D. C.

Here's Proof



"Made \$6,000 in 3 years"

"Soon after the depression started, I found myself without a job, but I was well protected with N. R. I. training. I swung right to full-time Radio servicing and I have made over \$6,000 in a little over two years."—W.M. SPARTIVENT, Sparty Radio Service, 93 Broadway, Newark, N. J.

"\$500 a Year in Spare Time"



"Although doing spare-time Radio work only, I have averaged about \$500 a year extra in addition to my regular income. Full-time Radio work would net me many times that amount."—EDW. H. FAWCETT, Slough Rd., Ladner, B. C., Canada.



"Good Position, Good Pay"

"I am Chief Operator at Radio Station W8MK. This is a good position with good pay. I have advanced in Radio right along. I recommend N. R. I. to anyone who wants to be successful in Radio."—J. O. H. HALL-DEK, J.L. 3 Broxey Apts., Southern Hills, Dayton, Ohio.

ACT TODAY

Without obligating me send your book which explains the opportunities in Radio and Television. I will explain your opportunities in Radio and Television. (Please print plainly)

NAME _____ ADDRESS _____ CITY _____ STATE _____

Opportunity Ad-lets

Advertisements in this section attract cents a word for each insertion. Name, initial, and address must be included at the above rate. Cash should accompany all classified advertisements unless placed by an accredited advertising agency. No advertisement for less than 10 words accepted. Ten per cent discount for 6 issues, 20 per cent discount for 12 issues. Objectionable or misleading advertisements not accepted. Advertisements for the January, 1934, issue must reach us not later than October 28th. EVERYDAY SCIENCE AND MECHANICS, 100 Park Place, New York, N. Y.

Advertising Agencies

ADVERTISE: 24 Words in 250 newspapers \$10.00. Lists free. Advertising Service Bureau, 4050 Drexel, Chicago.

Agents Wanted

FREE Booklet describes 87 plans for making \$20-\$100 weekly in home or office. Business of your own. Edite Co., 214-J Grand Street, New York.

BIG Money applying gold initials on automobiles. Fastest thing today. No experience needed. Free Samples. "HAIAC," 1084 Washington, Boston, Mass.

FREE Literature describing many money-making plans. K-Heffort, 4042 N. Keeler, Chicago.

MAKE Your own products. Employ agents yourself. Toilet articles, soap, extracts. We furnish everything. Valuable book free. National Scientific Laboratories, 1970W Broad, Richmond, Va.

MAKE money. Collect \$8, keep \$5. Two quick-selling, dollar per month, "hard times" life policies. Fidelity Mutual Benefit Association, Department A, Rockford, Ill.

WINDOW SIGN LETTERS

500% profit. Free Sample.

METALLIC CO., 441 N. Clark, Chicago.

CASH income daily retooling mirrors at home. Re-plating auto parts, reflectors, lightbrows, etc. Outfit furnished. Write SPINK & L. Plater, 955 Marion, Indiana.

MAKE Products yourself—Tested Formulas. Catalog free. Grinstead Laboratory, Edwardsville, Illinois.

GOOD income plating auto parts, reflectors, mirrors, by new method. Outfits furnished; free particulars. Gun-metal Co., Ave. E, Decatur, Ill.

Boats

BUILD 12-foot rowboat, blueprint, 30c; 16-foot utility outboard, 50c. Robert Stewart, 2541 East 19th, Brooklyn, N. Y.

Business Opportunities

PROFITS Quick, enormous, no selling. Men, women, get facts. McArthur Co., Desk 21, Butte, Montana.

MAKE Products yourself—Tested formulas—catalog free. Grinstead Laboratory, Edwardsville, Illinois.

LIQUID Marble—anyone can make! Applied with brush or molder. Rubberlastic molds; liquid porcelain; composition flooring. Big money—making these! Particulars free. Rapid Service, Edwardsville, Illinois.

Chemistry

EXPERIMENTERS—Join Science Club. Apparatus and monthly magazine given free! Membership, 25c now. Sciencecraft, T-5049 Bernard, Chicago.

Clubs

JOIN: American Amateur Physicians' Society. Journal, particulars, 10c. Westtown, Penna.

Detectives

BE A Detective. Make secret investigations. Experience unnecessary. Write, Ray Stultz, 1623 W. Grand, Chicago, Ill.

Dogs

BEAUTIFUL Registered bull pups, \$15. Buildings, 561-ERM, Rockwood, Dallas, Texas.

Educational Bargains

USED Correspondence Courses and Educational Books sold or rented, inexpensive. Money-back agreement. Catalog listing 3000 bargains—FREE. (Courses Bought.) Lee Mountain, Pisgah, Alabama.

Formulas and Trade Secrets

FORMULAS—All kinds, Guaranteed. Catalog free. "KEMICO," B-17, Parkridge, Ill.

FORMULAS—Interesting literature free. K-Belfort, 4042 N. Keeler, Chicago.

TESTED Formulas. Newest—guaranteed. Catalog free. Grinstead Laboratory, Edwardsville, Ill.

"CHEESE CHIPS"! Genuine formula! Big money makes! Tremendous profits! Easily made. Information free W. J. Lutz, 119-K, North 8th, Springfield, Ill.

SUCCESS with your own products. Formulas, processes, analytical services. Formula, catalog free. D. Thaxly Co., Washington, D. C.

For Inventors

INVENTORS—Sell your inventions before patenting. Free particulars. Write W. T. Greene, 945 Barrister Bldg., Washington, D. C.

INVENTIONS new salable before patenting. Safe, practical. For information, write Chartered Institute, 550 Barrister Bldg., Washington, D. C.

WANTED: New meritorious articles to manufacture or sell on a royalty basis. Chas. Muller, 809 West Madison St., Chicago.

Hypnotism

"THE Master Hypnotist"—25c. Dr. Look, (Hypnotist), D-1013, Palatine, Illinois.

Instruction

WANTED: Men—women, age 18 to 50, qualify for steady future government positions; commences \$105-\$175 month. Common education sufficient. Write, Instruction Bureau, 149, St. Louis, Mo.

FORESTRY Work easily available, \$175 month. Cabin, Hunt, trap, patrol. Get details immediately. Mason Bureau, K-18, Denver, Colorado.

Magic

WE Supply every noted magician with magic. Illustrated catalogue, 25c. Holden, 324 West 42nd St., New York City.

Mail Service

FOR Personal or business purposes. New York address is an asset to you. Prompt, reliable service. \$2.00 monthly. (Renewed daily.) New York Mail Service, 15 Park Row, New York City.

Modelmaking

LARGEST Assortment of model airplane and boat accessories in the world. Send for complete catalog. Sotley Company, 1873B Gates Avenue, Brooklyn, N. Y.

Motorcycles and Bicycles

SEND 15c for illustrated used Motorcycle catalog. Large stock. Bargains. Indian parts. Accessories. Indian Motorcycle. Sales, Kansas City, Mo.

Motor Winding Data

MOTOR Winders: Winding data, 100 motors, special section, various horsepower and voltage \$1.00. Motor Data Service, 5003 Monroe, Kansas City, Mo.

Patent Attorneys

PATENTS Secured. Low cost. Write for book "How to Get Your Patent" and Record of Inventor's Certificate. Personal skillful service assured. 35 years experience. Preliminary advice free. L. F. Randolph, 847 Victor Building, Washington, D. C.

PATENT—Small ideas may have large commercial possibilities. Write immediately for information on how to proceed and "Record of Invention" form. Delays are dangerous to patent matters. Clarence A. O'Brien, 5447 Adams Building, Washington, D. C.

PATENTS. Booklet free. Highest references, best results. Promptness assured. Watson F. Coleman. Registered Patent Attorney, Victor Building, Washington, D. C.

Photo Developing

FILMS Developed by 35 mm roll; prints 3c each. Ask for special bargain list. Resnapco Photo Finishing Company, 157 Roll Ave., Roanoke, Va.

Printing

500 TWO-Color letterheads, \$1.75. Samples free. Delmar, 947-D North Rural, Indianapolis.

Salesmen

WONDERFUL opportunity, \$20.00 a day can be earned. No experience necessary. You can start at once. Showing the latest thing out. Self-protection and home protection at cost. Ages 1 to 80. Not insurance but provides benefits up to \$1000.00 natural or accidental death. \$20.00 per week if sick or injured. Address National Aid Society, Dept. F, Springfield, Illinois.

Songwriters

SONGWRITERS! Poems, melodies. Amazing opportunity. Publisher, D26, 2104 Keystone, Chicago.

Stuttering and Stammering

STUTTERING and stammering easily and effectively cured at home. Booklet free. Box 807, Butler, Penna.

Breaking Up Tornadoes

(Continued from page 905)

ment that speeds of 300 miles per hour or 440 feet per second, and even more, may be attained, which is most unlikely to be the case. It must be borne in mind that an air blast of 150 feet per second readily carries off bricks and other such heavy objects.

(2) Contrary to popular notion, attributing to the tornado immense energy, it has much of the peculiarity of an explosive. Its power is great because of concentration and swiftness of action, but the energy is surprisingly small. Just to give a rough approximation, consider a whirl of an outside diameter of 1200 feet at the top, about the same height, and a diameter of 300 feet at the base (See Note C). The same energy would be developed by the consumption of 1.24 tons of gasoline or 5.74 tons of dynamite. It should be stated, however, that this estimate is by far too high; for the whole funnel is not filled with air of uniform density and not all of it spun at maximum speed.

(3) The tornado whirl is a huge pump, drawing air through the opening at the top and discharging it from the periphery (rim) at the same rate, simultaneously producing rarefaction in the interior. In this respect its action may be likened to that of a multi-staged vacuum pump; for, as the air rushes from the top to the base, more and more of it is drawn to the periphery. Increasing progressively the vacuum which may thus attain a high value near the ground. That accounts for the gradual contraction of the whirl. What degree of rarefaction is actually reached in this monstrous contrivance of nature may be roughly estimated when considering that, for any horizontal section of the funnel, the centrifugal force of the air is balanced by the oppositely-directed differential pressure existing between the outside and interior of the whirl. Other things being alike, the centrifugal force is inversely as the **radius of gyration** (average distance of the mass from the center); therefore the contraction of the funnel is, at least, a coarse measure of the rarefaction.

To be explicit, if the diameter close to the ground is one quarter of that near the top, then it may be safely inferred that the vacuum at the base must be about four times higher than in the top region, where there is no appreciable contraction.

As the measured pressure difference in pumps is somewhat greater than that given by the formula (Note D) it is tolerably certain that in the case considered a vacuum of not less than four inches would be attained.

(4) Most of the mechanical effects of a tornado are, as a rule, greatly intensified through water, dust, sand and other objects carried by the blast. Even though these materials may be present in a very small percentage by volume, they are hundreds or thousands of times heavier than the air, and may add enormously to the momentum and impact.

(5) The transitory (from place to place) motion of the funnel is rather across, and not in the direction of the wind, as commonly believed. This is due to its rapid rotation, causing the so-called Bernoulli or Magnus effect, only much more intense. The force pushing it across the wind may be many times greater than that urging it along the same. The whirl is propelled from the side of greater static pressure, where the rotation is against the wind and to-

FOR SALE, BARTER AND EXCHANGE

As an aid to our readers, all advertisements to be inserted in this department are accepted at 2c a word; name, address, street number, etc., each counting for one word. No advertisements for less than fifteen (15) words accepted. The Publishers are not responsible for difficulties arising out of the trades. In this department, only advertisements for private individuals can be accepted. EVERYDAY SCIENCE AND MECHANICS reserves the right to reject any advertisement that conflicts with the policy of this magazine. Send all "Swap" advertisements to EVERYDAY SCIENCE AND MECHANICS, 100 Park Place, New York, N. Y.

BOYS! YOUNG MEN! LEARN TO FLY! Guaranteed home-study course in aviation, only \$1.00, postpaid. Complete, accurate, reliable. Special offer. Rush dollar now. Your money back if not satisfied. Address—Aviation Service, Box 182, Robertsdale, Penna. Fathers! An entire flying education for your boy. A wonderful Christmas Gift.

WILL SWAP ENCYCLOPEDIA BRITANNICA. 9th edition. 25 massive volumes, over 21,000 pages crammed with useful knowledge. What have you to offer. Albert Taylor, Steele Place, Amityville, New York.

NEW MORALS for OLD

Now comes a daring new book about sex, different from any other you may have ever read before. It is a book written especially for men and women who are not afraid to face the facts, and who want to learn the real truth about sex and sexual intimacies.

This startling new book, by Dr. William J. Robinson, discusses in the plainest language everything pertaining to the sex life, both in marriage and out of it. Is it wise to think of morals only as it concerns sex? Is it right to think of love as being possible only in marriage? These vital questions, and many more are discussed openly and frankly in this great book. It gives you an amazing new view of the whole question of sex, as seen by a famous Sexologist whose works are praised the world over.

This Partial Table of Contents gives you a faint idea of the value and the completeness of Dr. Wm. J. Robinson's wonderful new book, entitled:

SEX, LOVE and MORALITY

Principles of General and Sexual Morality
Promiscuous Relations
Extra-Marital Relations, with 10 Illustrations
When Love Complicates the Problem
Frankness Between Husband and Wife
The Domestic Trio
Love and Sexual Intercourse
Wrong View of Sanctities and Duties of Love
Sexual Favors
The Double Standard
Unnatural Methods of Love
Definition of Prostitution
Prostitute's Moral Level
Prostitute's Mental Level
Ethics of Prostitution

Does Prostitution Supply a Genuine Need?
Will Prostitution Ever Disappear Entirely?
What to Do With the Prostitute
Three Kinds of Prostitutes
Homosexuality, Transvestitism, and Sadism
Rape
Incest
Masturbation
Abortion
Provenception or Birth Control
Divorce
Alimony
Breach of Promise
Illegitimacy
Miscogestation
Sex—What to Do About It



Limited Edition, Write Today

Because of its unusual frankness, this great book may be obtained only by subscription. The number of copies on hand is strictly limited, and once they are gone you may never have another opportunity to obtain "Sex, Love and Morality." Take no risks. Make certain that YOU will own a copy of this vitally important work. Mail your order now, before you turn this page.

Greenpark Company
6625 Park Place,
New York, N. Y.

Enclosed is my remittance for \$5.15, for which please send me prepaid in plain wrapper, a copy of the Limited Edition of "Sex, Love and Morality" by Dr. William J. Robinson.

Name.....
Address.....
City.....State.....

Check here if book to be sent C. O. D.

wards which it leans, in the direction of the opposite side where the reverse condition exists. It is well to remember this in such a storm. If the observer sees a leaning funnel, he is in no immediate danger, but if the funnel appears straight he should run for shelter at once.

It will now be easy to show how a large and very heavy body, such as a loaded railroad car or locomotive, can be lifted by the tornado and transported to considerable distance. American locomotives, which are the biggest in the world, may have a length of 66 and a width of 11 1/2 feet, presenting thus 760 square feet in horizontal projection. At the moment the whirl strikes the vehicle, the wheels, connections and other obstacles under the main body arrest the motion of the air, causing a static pressure of 138 pounds per square foot in excess of that of the atmosphere. But as determined above, owing to the vacuum, a pressure difference of four inches of mercury (that is, two pounds per square inch or 288 pounds per square foot) is maintained, making the whole difference of pressure between the spaces under and above the locomotive 288+138=426 pounds per square foot. The total upward push exerted on the exposed area of 760 square feet is thus 323,760 pounds, which is much more than the weight of such a locomotive (estimated at 280,000 pounds when fully equipped for service).

Ordinarily, the weight should be much smaller; and one can readily see that the vehicle may be instantly raised in a spiral, accelerated and hurled away tangentially to great distance. The average person may be surprised that an insignificant vacuum is sufficient for so stupendous a display of force; but the figures afford an unmistakable proof. I may add that I have assumed minimum values which will be, in all probability, greatly exceeded.

The constant fear of danger from tornadoes and the great losses of life and property which they cause in certain parts make it very desirable to find some means of effectively combating, if not preventing them. Whenever man attempts to interfere with the order of things determined by immutable laws, he finds that his efforts are utterly insignificant when compared with the vast movements of energy in Nature.

One of the greatest possible achievements of the human race would be the control of the precipitation of rain. The sun raises the waters of the ocean and winds carry them to distant regions, where they remain in a state of delicate suspension until a relatively feeble impulse causes them to fall to earth. The terrestrial mechanism operates much like an apparatus releasing great energy through a trigger or priming cap.

If man could perform this relatively trifling work, he could direct the life-giving stream of water wherever he pleased, create lakes and rivers and transform the arid regions of the globe. Many means have been proposed to this end, but only one is operative. It is lightning, but of a certain kind.

More than 35 years ago, I undertook the production of these phenomena and, in 1899, I actually succeeded, using a generator of 2,000 horsepower, in obtaining discharges of 18,000,000 volts carrying currents of 1,200 amperes, which were of such power as to be audible at a distance of 13 miles. I also learned how to produce just such lightnings as occur in Nature, and mastered all the technical difficulties in this connection. But I found that even the small

FREE RADIO CATALOG

1934 RADIO CATALOG

Write for our new catalog... most complete line of latest radio sets, service men's supplies, replacement parts at lowest wholesale prices.

ALLIED RADIO CORP.

832 W. Jackson Blvd. Dept. F Chicago

"What Makes It Light?"

Make Big Money Asking This Question

MYSTERY CIGAR LIGHTER

Entirely new principle of ignition. It surprises, it amazes, it sells like wildfire. No Flint or Friction. All guaranteed. Sample with Sales Plan 35c. Sample Gold, Silver or Chromium Plated \$1. Agents write for a real money-making proposition.

NEW METHOD MFG. CO., Desk EG-12, Bradford, Pa.

RAISE SELL GOLD IN YOUR HOME

MUSHROOMS MONEY

MAKE \$40 or more EVERY WEEK in spare time. Grow work; big profits. Grow in cellar, shed, etc. We supply materials! TEACH YOU to earn big profits and buy your crop. Send for FREE illustrated booklet containing COMPLETE plans. Write today. Ask for Free 25 Thermometer offer.

ILLINOIS MUSHROOM INDUSTRIES
54 W. Illinois St. Dept. 609 Chicago, Ill.

MAKE 700 TOYS an Hour for 1 Each!

You and profit, making and selling metal toys. Complete outfit and ordering outfit only \$2.25. Each outfit would make three different figures. Ask your dealer for details. Write for State choice of U. S. Soldiers, Indians, Machine Gunners, Raiders, Continental Soldiers, Footies or Baseball players.

FREE BOOK of Illustrations and instructions sent on request.

RAPAPORT BROS.
715 W. Ohio St. Chicago

TRICKS WITH 110 VOLTS

Electric Fun! Make toy motors, buzzers, tops, machine guns, arcs, shockers, lights obedient to the voice, window novelties, floating rings, spirit rapping—all kinds amusing and practical electrical devices. Our book gives full directions for doing 200 stunts with 110 volts. A. C. Price postpaid \$1.00.

Cutting & Sons, 123 E. St., Campbell, Calif.

3 DIMES WILL BUY THIS UNIQUE TYPEWRITER

A REAL SURPRISE! WE WILL BUY YOUR OLD TYPEWRITER! WE WILL REPAIR YOUR BOYS AND GIRLS' TYPEWRITERS!

MYSTERY CLUB

Join "The Junior Magician's Club" Headquarters in Magic City of Hollywood and Membership Card. Also FREE puzzle.

PALACE OF MYSTERY
Dept. A Box 82 Hollywood, Calif.

RAISE RABBITS FOR US

WE SUPPLY STOCK AND BUY WHAT YOU RAISE

PAYING YOU HIGHEST PRICES—Established 20 Years. Rabbit book catalog and monthly market bulletin. Highest prices we pay our breeders. 10c. Address: OUTDOOR ENTERPRISE CO., Inc., Box 436 NEW CITY, N. Y.

50 WEEK HOME!

Experience unnecessary. Grow year round in basement, cellar, garage. Idle places. We buy crop. FREE HOOK.

MUSHROOM GROWERS ASSOCIATION
431-FY N. Clark St. Chicago, Illinois

Print Your Own

Cards, Stationery, Circuits, Paper, etc. Save money. Print for others, big profit. Complete outfit \$8.95. Job press \$11. 829, Rotary Bldg. All easy rules sent. Write for catalog. Prices type etc. THE KELSEY CO., P-18, Meriden, Conn.

Make Money at Home!

Grow Mushrooms! Experience unnecessary, we tell you how. Big demand! Write for Mushroom Book free.

American Mushroom Industries, Ltd.
175 Wellington Bldg., Toronto, Ont.

EARN up to \$25 A WEEK or More

FOR CHRISTMAS

A Gift Surprise for any occasion, for Machines and Toolmakers. Free catalog.

BERNSTEIN TOOL CHESTS
724 Columbia St., Dayton, Ohio

New! New!! New!!!

Two New 25c Short Wave Books HERE IS GREAT NEWS



These new books will be welcomed by all short wave experimenters, short wave fans and short wave enthusiasts, the same as our former two books, **HOW TO BUILD AND OPERATE SHORT WAVE RECEIVERS**, and **HOW TO BECOME AN AMATEUR RADIO OPERATOR**, were welcomed by thousands of our short wave friends.

In conformity with the times these books have been priced at 25c instead of 50c, which is the price of our other books. Yet the two new 25c volumes contain a tremendous amount of information. The type and illustrations have been chosen in such a manner as to give you almost as much for your 25c as you received for your 50c before.

You make no mistake in getting either or both of these books—and we know from our many years of experience with short wave enthusiasts that you will thank us for having made these books possible.



Ten Most Popular Short Wave Receivers, How to Make and Work Them

This new volume is a revelation to all those who wish to build their own short wave receivers. The editors of **SHORT WAVE CRAFT** have selected ten outstanding short wave receivers and these are described in the volume. Everything worthwhile about every one of the ten receivers is described in the text. Each receiver is fully illustrated and each receiver has a complete layout, pictorial representation, photographs of the set complete, hookup and all worthwhile specifications. Everything from the simplest one-tube set to a 5-tube TRF receiver is presented. Complete lists of parts are given to make each set as complete as it is humanly possible to do.

Contents
 1 R.F. Pentode SW receiver having two stages of TRF—2-Tube receiver that reaches 12,000 miles mark—My Deluxe SW receiver—Bismarck 2-tube 12,000 mile D.C. receiver—Graf-Clegg SW receiver—Denton 2-tube All-Wave receiver—Denton—Stand-By—The Stand-By—Electrified Short Wave Mergal—Cosmopolitan SW receiver—SW Pentode—My idea of a good SW receiver—A Good—One-Tube—

IMPORTANT
 THERE IS NO DUPLICATION WHATSOEVER BETWEEN THIS BOOK AND OUR OTHER VOLUME—**HOW TO BUILD AND OPERATE SHORT WAVE RECEIVERS**. ALL THE MATERIAL PUBLISHED IN THIS NEW BOOK HAS NEVER APPEARED IN ANY BOOK BEFORE.

Each book contains 40 pages—over 75 illustrations—25c each
 NOT SOLD ON NEWSSTANDS—MAIL COUPON TODAY!

SHORT WAVE CRAFT, 96-98 Park Place, New York City. ES-1033

Gentlemen:

[] I enclose herewith 50c, for which please send me, prepaid, a copy of your new book "Ten Most Popular Short Wave Receivers. How to Make and Work Them."

[] I enclose herewith 25c for which please send me, prepaid, a copy of your new book, "The Short Wave Beginner's Book."

[] I enclose 50c for which please send me, prepaid, your two books, "Ten Most Popular Short Wave Receivers. How to Make and Work Them" and "The Short Wave Beginner's Book."

(Send money order, check, or cash or new U. S. stamps. Register letter if it contains currency or stamps.)

Name.....Address.....

City.....State.....

WOOD CARVING

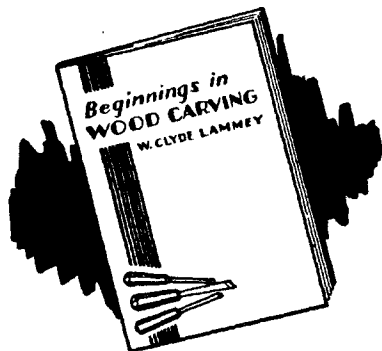

CARVING in wood is one of the most fascinating of pastimes. With a few inexpensive hand tools you can decorate furniture and wood objects and create many beautiful carvings.

Clyde Lamme, an authority on wood carvings wrote a series of articles that have run in early issues of *Popular Homecraft* and we have gathered these together in a big 9 x 12 book solidly made that will give you the finest instruction possible on this most interesting subject.

It is profusely illustrated and there are many designs showing you step by step how to proceed.

You'll be delighted with this book. 60 cents—stamps—coin—add 5c exchange to checks.

HOMECRAFT BOOK SHOP
 148 EAST SUPERIOR ST. CHICAGO, ILL.

manifestations are of comparatively small energy. It is entirely within our power to destroy them, or at least render them harmless; and all the more easily, since meteorology is becoming a positive science and weather forecasting reliable.

A service with standard bombing planes or swifter types might be organized for this purpose by the Government, for the necessity is real. The tornado, owing to its small energy, extreme mobility and delicate balance between the external and internal pressure, is a very vulnerable object and can be undoubtedly destroyed by comparatively small charges of suitable explosive. The whirling mass can also be easily deflected in any desired direction by exploding a charge even at a considerable distance from it. The task would be further facilitated by the relatively small translatory velocity of the tornado, especially in view of the present means for instant signalling.

I believe, however, that telautomatic devices offer effective means for combating tornadoes. Since I exhibited the first apparatus of this kind, John Hays Hammond, Jr., who has acquired a great mastery of the art, made demonstrations on a large scale, showing the practicability of distant control of complex machinery. It would not be difficult to provide special automata for this purpose, carrying explosive charges, liquid air or other gas, which could be put into action, automatically or otherwise, and which would create a sudden pressure or suction, breaking up the whirl. The missiles themselves might be made of material capable of spontaneous ignition. Many experts are now available for such service and manufacturers can be found competent to carry out any plans.

A Government department might be organized, headed by such a man as John Hays Hammond, Jr., and a systematic study of the problem made. The carrying out of the scheme would give new opportunities for manufacture and employment, besides securing other advantages. There is no doubt that, if such an undertaking were inaugurated and many minds set to work, effective methods and means would be eventually developed and great loss of life and damage to property prevented.

NOTE A: Taking the heating value of the compound as 4100 B.T.U., a constant pressure of twelve thousand atmospheres should be attained; the theoretical temperature of the combustion products being about 8000° F. The highest possible speed would be reached if the gases were to escape into the atmosphere through a perfect divergent nozzle. In this case, the initial absolute temperature would be $T_1 = 8460^\circ \text{F}$; hence the absolute temperature of the fully-expanded gases $T_2 = \frac{0.285}{0.8460/12000} = 583^\circ \text{F}$. Accordingly, assuming the specific heat at constant volume $C_v = 0.33$, the available energy is $W = 7877 \times 0.33 = 2600 \text{ B.T.U.}$, and the maximum theoretical velocity $V = \sqrt{64.4 \times 778 \times 2600} = 11400 \text{ feet per second.}$

NOTE B: Let the stalk be one foot long, one-eighth of an inch in diameter and of a specific gravity of 0.4 as compared with that of water. The section is then about $\frac{1}{80}$ of a square inch or $\frac{1}{144 \times 80} = \frac{1}{11520}$ of a square foot and, consequently, the volume $\frac{1}{11520}$ of one cubic foot. Since one cubic foot of water weighs 62.45 pounds, the weight of an equal volume of straw will be $0.4 \times 62.45 = 25 \text{ pounds}$, hence the weight of the piece of straw $\frac{25}{11520}$ pounds and its mass $M = \frac{32 \times 11520}{25} = 14784 \text{ foot pounds}$

and will be exhausted in overcoming a resisting force r which the stalk encounters while piercing the wood. If the distance of penetration is $\frac{1}{2}$ inch or $\frac{1}{24}$ of a foot, then the equation will hold true

$$\frac{22500 \times 25}{64 \times 11520} = r \times \frac{1}{24}$$

from which follows

$$r = \frac{24 \times 22500 \times 25}{64 \times 11520} = 18.31 \text{ pounds}$$

This is the mean value of the force or pressure produced, its maximum being $2 \times 18.31 = 36.62 \text{ pounds}$

As this pressure is exerted on an area of $\frac{1}{80}$ of a square inch, the force per square inch will be $F = 36.62 \times 80 = 2929.6 \text{ pounds}$

NOTE C: The volume is $0.2618 \text{ ft} (D_2^2 + D^2 + d) = 0.2618 \times 1200 (1200^2 + 300^2 + 1200 \times 300) = 0.2618 \times 1200 (1200^2 + 1200 \times 300) = 593760000 \text{ cubic feet}$, the weight about $593760000 \times \frac{8}{100} = 47500000$ and the mass $M = \frac{47500000}{32} = 1484400 \text{ pounds}$. If all of it would rotate at the top speed $V = 235 \text{ feet per second}$, the kinetic energy would be $\frac{1}{2} M V^2 = 742200 \times 55225 = 40988000000 \text{ foot pounds}$, equivalent to $\frac{40988000000}{778} = 52700000 \text{ B.T.U.}$

NOTE D: When a mass of air is rotated in a casing with inlet and outlet openings, by a system of discs or other means, the peripheral velocity being V feet per second, a pressure difference of approximately $\frac{V^2}{64} w = \frac{V^2 \times 0.08}{64} = \frac{V^2}{800}$ pounds per square foot is produced between the suction and discharge orifices. If $V = 235 \text{ feet per second}$, then $\frac{V^2}{800} = \frac{55225}{800} = 69 \text{ pounds}$

per square foot, or $\frac{69}{144} = 0.48 \text{ pounds per square inch}$; corresponding to a vacuum of a little less than one inch.

New Devices

(Continued from page 877)

The last item is another household utility which takes into consideration the fact that all have no electric power. It is a standard washer type, equipped by its maker with a small four-cylinder gas engine, which is started by a foot-pedal. A friction-drive pump will empty the tub in less than two minutes. It holds ten gallons of water, and washes six pounds of clothes at one time.

Scientific American

March, 1934, pp. 132-134, 163-165

POSSIBILITIES OF ELECTRO-STATIC GENERATORS - by Nikola Tesla

The knowledge of static electricity dates back to the earliest dawn of civilization but for ages it remained merely an interesting and mystifying phenomenon. Virtually nothing was done towards the development and useful application of the principle. The first distinct stimulus in this direction was given by the discoveries of Franklin and Leyden in the latter part of the 18th Century.

In 1777 Cavallo devised a cylindrical friction machine and from that time on there was a slow but steady evolution of friction and influence machines until the modern Wimshurst, Holtz, Toepler, and other types were produced. Among these machines the one invented by Wommelsdorf 30 years ago was, probably, the most effective. It yielded a current of six-tenths of a milli-ampere and in the present state of science it could be successfully employed for charging large aerial capacities and stepping up its terminal tension of 150,000 to many millions of volts.

Numerous attempts have also been made to generate static electricity by friction of fluids and solid particles but from the earliest records to this day the belt has proved to be the simplest and most convenient means for the purpose. Static electricity from this source gained in importance when evidences accumulated that it was capable of interfering seriously with operations and causing accidents in paper factories, flour mills, and similar establishments. In the early nineties my electrodeless vacuum tubes became extremely popular and were frequently lighted from belts and later Roentgen tubes were operated in the same manner. It is quite easy to improvise such a generator and obtain interesting results under favorable atmospheric conditions.

A remarkable device of this kind, embodying new features, has been recently developed by Dr. R. J. Van de Graaff at the Massachusetts Institute of Technology, and is attracting extraordinary attention. (See page 96, February, 1934, SCIENTIFIC AMERICAN. - Ed.) It is hailed as a revolutionary invention with which wonders will be achieved. The technical papers refer to it as a Colossus, a Master Key expected to unlock the secrets of nature. Naturally enough imaginative scribes have built Spanish castles on this foundation. So it comes that even such an ably edited paper as *The New York Times* informs its readers of a contemplated use of this generator for long distance transmission of power. According to a *bona fide* report in its issue of December 5, 1933, "the possibilities of the colossal generator have been worked out in theory and it now remains to apply it in practice." However visionary this scheme may appear it is not absolutely impossible. A wise Macedonian king said: "No wall is so high that a mule loaded with gold could not jump over it." With unlimited capital and regardless of returns, it might be carried out.

In view of many articles and editorials written in the same vein, which have amazed the layman and amused the expert, it may not be amiss to examine the merits of this odd contrivance in the light of well demonstrated scientific facts.

But first I want to point out an apparent discrepancy in the descriptive reports and photographs showing the apparatus in action, which is illustrated in the accompanying photographs, and consists of two aluminum spheres 15 feet in diameter supported on insulating columns six feet in diameter. Electricity is supplied to the spheres by paper belts charged from a "sprayer." With terminals of such dimensions much higher voltages should be obtained. In most of the treatises it is assumed

Reprinted with permission. Copyright © 1934 by Scientific American, Inc.
All rights reserved.

that the surface density, that is, the quantity of electricity stored per square centimeter of a spherical conductor, can not exceed eight electrostatic units without break-down of the surrounding air. As a matter of fact the density can be pushed up to 20 units before power-consuming streamers appear.

This being the case, the limiting voltage of a sphere having a diameter of 15 feet should be 16,964,700 and, consequently, the potential difference between two such oppositely charged spheres, very far apart is 33,929,400 volts. It may be useful to state, however, that such large spheres placed at a distance of 55 feet between centers, as contemplated, will influence each other to a considerable extent, increasing their capacities. At this distance the increase will be about 16 percent, which should be taken into consideration when estimating the charge.

The desired difference of potential could be obtained with much smaller spheres and it would seem preferable to employ them as they would yield sparks in quicker succession. Some of the photographs under the terminal pressure of 7,000,000 volts are puzzling because the surface density in this case was only a little over 4 electrostatic units. Furthermore, sparks are shown to pass copiously along the insulating supports. This is a serious difficulty encountered in working with very high tensions but by properly shaping the under side of the sphere and resting it on a support well up in its interior, besides providing a liberal side clearance, the discharges are prevented from following the column and no further trouble is experienced even with the highest potentials. My wireless tower on Long Island, erected in 1902, carried a sphere which had a diameter of 67½ feet and was mounted in this manner. It was to be charged to 30,000,000 volts by a simple device for supplying static electricity and power.

Most people, and not a few electricians, will think that very long and noisy sparks are indicative of great energy, which is far from being the case. An impressive display of this kind, at several million volts, can be readily obtained with any wide leather or fabric belt in dry weather. The only requirement is that the outward surfaces of the highly charged capacity elements be arranged along an ideal boundary everywhere of small curvature. But the electrical energy is trifling and this applies to all electrostatic generators which have been proposed, irrespective of size.

One does not need be an expert to understand that a device of this kind is not a producer of electricity, like a dynamo, but merely a receiver or collector with amplifying qualities. All its energy is derived from electricity which is generated through friction or supplied by the sprayer and pumped into the terminals by the belts. If the columns were as tall as the Empire State Building and the spheres 500 feet in diameter the monstrous machine could not have any more energy than is supplied to it by the electrified belts and no matter how much improved, this type is fatally doomed to small output and low efficiency on account of the existing limitations and the wastefulness of the process of conveying the charges from their sources to the terminals.

As the writers of articles regarding the "Colossus" confine themselves to controlling its size, voltage and possibilities, but give little hint regarding its mode of operation and power performance, I shall endeavor to advance the needed knowledge. With this object let it be assumed that the spheres are placed at a distance of 55 feet from center to center and that the potential difference between them is 10,000,000 volts. Ordinarily, the electric capacity of such a sphere is equal to its radius, namely 225 centimeters, but as before explained, 16 percent should be added to this, making 261 centimeters equivalent to 0.00029 microfarad. Consequently, when the regime is established, each sphere being at a potential of 5,000,000 volts, the electricity stored on each will be 0.00145 coulomb. If this quantity were supplied every second, the current would be 0.00145 ampere. An incandescent lamp of 25 watts requires a current 150 times more intense.

In estimating the amount of electricity furnished to each terminal per second, only the sprayer need be considered as it supplies much more than could be generated by friction of the belts. The device used has not been clearly described but it is sufficient for the purpose of this dissertation to know that it operates at 20,000 volts and energizes, through rows of points, the two belts which are said to be four feet, or 120 centimeters, wide. Assuming that they are run at a speed of 100 feet or 3,000 centimeters per second, the area covered in this time interval would be $120 \times 3,000 = 360,000$ square centimeters. If it were possible to charge the belts uniformly to a surface density anything like that existing on an electrified particle, the output of the machine would be very great. But this can never be realized. The following approximate estimate will show what may be reasonably expected.

The discharge of electricity from points has been extensively investigated and from the data available and my own observations I find that the current through each point at 20,000 volts will be about 0.0001655 ampere. No advantage would be gained by a very close spacing of the points on account of their mutual reaction but I shall make allowance for as great a number as seems practicable, say, 200, in which case the integral current would be $200 \times 0.0001655 = 0.0331$ ampere.

Now, electricity is transferred from the points to the belt by minute bodily carriers - the molecules of the air. When such an electrified particle comes in contact with a large conducting body it gives up almost all of its charge to the same, but to an insulator, as the belt, it can impart only a very small portion owing to the strong repulsion between the charge deposited and that remaining on the particle. From theoretical considerations it appears that the part usefully applicable will, in all probability, not exceed 1/150 of the whole charge on any particle thrown against the belt. The current from the sprayer is 0.0331 ampere, that is to say, it conveys a total charge of 0.0331 coulomb per second and of this the belt will carry off only 0.00022 coulomb equivalent to a current of 0.00022 ampere. This means that 99.33 percent of the energy supplied by the sprayer is lost, and illustrates the appalling inefficiency of this method of electrification.

As will be seen, the device delivers to each belt energy at the insignificant rate of 4.4 watts and is, therefore, virtually of no effect on the power output of the machine except that it imposes a limit to the same. This is important to remember in view of the general impression created by the earlier reports that all energy is drawn from the sprayer. Since the quantity of electricity stored on the spheres remains constant it is evident that the overflow current between them under normal working conditions must be 0.00022 ampere so that at the potential difference of 10,000,000 volts the machine should develop 2200 watts. As the supply from the exciter is entirely negligible the questions will be asked: Whence come energy and power? How is it produced? The answer is simple. It is derived from the belts which perform the work of transporting the charges imparted to them against the repulsion exerted by the spheres. This force can be approximately determined. The permanent charge on a sphere will be, as shown above, 0.00145 coulomb or 4,350,000 electrostatic units. But 16 percent of this quantity is "bound" and should be left out of consideration. With due regard to the opening on the underside, the free capacity of each terminal may be estimated 222 centimeters, so that at five million volts $Q = 222 \times 5,000,000/300 = 3,700,000$ electrostatic units. The moving charge will be distributed over a length of the belt about equal to the height of the insulating column and with some allowances it may be taken at 24 feet. Assuming a belt speed of 6000 feet per minute this distance will be traversed in 0.24 of a second and, consequently the belt charge to be considered is 0.24 of the whole carried per second; that is, 0.0000528 coulomb or 158,400 electrostatic units. The upper end of the charged area is $7\frac{1}{2}$ feet and the lower $31\frac{1}{2}$ feet from the center of the sphere. The former is thus $r = 225$ c.m. and the latter $d = 945$ c.m. The charged area of the belt being $120 \times 720 = 86400$ c.m., it follows that the density of the

charge is $158400/86400 = 1.8333$ electrostatic units. Accordingly, if the distribution of the charge is perfectly uniform a transversal strip of the belt one centimeter long will contain a quantity $q = 120 \times 1.8333 = 220$ e.s.u.

Considering now a surface element of vanishing length dx , the charge on the same will be $qdx = 220 dx$ e.s. units of quantity and that on the sphere being $Q = 3,7000,000$ e.s. units, the repulsive force acting on the surface element at a distance x from the center of the sphere, will be $\frac{Qq}{2} dx$. Integrating this expression between the limits r and d , and substituting the values for Q and q , the force repelling the charged side of the belt is found to be $F = \frac{Qq(d-r)}{rd} = 2,756,420$ dynes or 2.81093 kilograms. At a speed of 100 feet or 30 meters per second the work is 84.3279 kilogram meters per second, equivalent to 0.82691 kilowatt. Both belts will therefore perform the work of 1.65382 kilowatts. This is 33 percent less than the theoretical electrical activity of the machine and as the power developed by the belts must be, at least, equal to the electric power one is apt to reach the conclusion that the sucking points do not draw off the entire charge, as has been tacitly assumed, and the current, instead of being 0.00022 will be proportionately smaller, that is, 0.0001654 ampere. But this view is found untenable for the limit to performance is imposed by natural law and not by the defects of a device which, moreover, could be readily improved. The discrepancy between the calculated power of the belts and the electric activity of the machine was all the more puzzling as the two quantities could not be harmonized by imagining any kind of theoretical working conditions. Finally, however, I recognized that the charge can not be uniformly distributed on the belt but must increase from the lower to the upper portion of the same. Indeed, such an effect might have been expected although the surface charge on an insulating body is not very mobile.

Supposing that the belt carried a film of oil meeting with a downward current of air. The obvious result would be a thickening of the film toward the top. Similarly, the electric film on the belt is "thickened" through the repulsion exerted by the terminal and the attendant piling up of the charge and it is only so that the exact balance between the mechanical and electrical power can be, under all conditions, automatically established. (See explanatory note on page 165.) The equality of these two quantities is an absolute and inevitable consequence of the law of conservation of energy, the remarkable feature of this process of dynamo-electric transformation being that it is effected with the highest efficiency, apparently without evolution of heat. Of course, there are great losses in the operation of the machine, but they do not concern the process itself.

In an instrument designed primarily for scientific investigation, the efficiency is of relatively small importance and I shall dwell on it for the sole purpose of showing that in any application as a power producer such a generator would be hopelessly handicapped. The air friction of the belts at a speed of 30 meters per second will require about 3.73 kilowatt. With the repulsion work, the load on them will be 5.93 kilowatt. Under the working conditions as outlined, the belt drive may have an efficiency of 90 percent and the motor 85 percent so that energy will be drawn from the electric mains at the rate of 7.75 kilowatt. The net performance of the sprayer at 20,000 volts will be 1.324 kilowatt but taking into account the efficiency of the whole apparatus, at least 1.6 kilowatt must be assumed. There are also dielectric, magnetic, and radiation losses, making the total power input, perhaps, 9.5 kilowatt while the output is only 2.2 kilowatt. If this estimate is reasonably approximate, an over-all efficiency of 23 percent is about as high as can be expected from any electrostatic generator of this kind.

It was shown that the charge on each sphere at 5,000,000 volts is 0.00145 coulomb but as only 0.00022 coulomb can be furnished per second, it will take about 6.6 seconds to charge the spheres to the full potential. I have assumed that the

current from the sprayer is continuous and not a rectified one, in which case the efficiency will be appreciably smaller. The streamers from pointed electrodes are generally considered as a sort of corona involving an insignificant loss of energy, but this view is erroneous. Such a discharge is very concentrated, approximating an arc in intensity, so much, in fact, that the heat evolved sometimes imposes a limit to the use of points.

In the absence of a detailed description, the performance of this sensational generator can not be closely determined and the actual results may be different from those I have indicated, but not greatly so. While the energy supply may be increased by raising the tension of the sprayer and increasing the number of the discharging and sucking points, there are limitations in this respect and it is perfectly evident that, no matter how big, such a contrivance is nothing more than a toy compared with the commercial machines employed in the transformation and transmission of electrical energy.

In view of this, and the low efficiency, its application will be confined to scientific experiments in which useful results may be achieved either by a feeble working current under high tension or by successive explosions. The latter method seems more promising because under proper conditions it is possible to discharge spheres in a time interval incomparably shorter than consumed in charging them and so amplify enormously the intensity of the actions.

Any device depending on static electricity carried by a belt will fail in damp weather and will have to be operated in a closed space in which the air is properly conditioned. Also, the belts are apt to deteriorate rapidly through the action of ozone, nitrous and nitric acid produced by the point discharge.

Although there is nothing radically new involved in the construction and working of this high voltage generator, it is, nevertheless, a distinct advance over its predecessors, the result of a scholarly effort towards producing an instrument suitable for scientific research, I think though, that whatever can be accomplished with it by virtue of the continuity of action, can be even better achieved by the use of cosmic rays. Moreover, the time consumed in the passage of a charged particle from one to the other end of the tube is so brief that it makes practically no difference whether the current is direct or alternating. In availing ourselves of the latter we are doing away with all the limitations as to voltage and strength of the current and, consequently, the intensity of the effects which it is the chief object to produce.

As far back as 1899 I made experiments with 18,000,000 volts and in some tests I was able to pass a current of 1100 amperes through the air. With my transformers a potential difference of 30,000,000 volts, or more, could be easily obtained and in the present state of the technical arts a tube or other device capable of taking up very great energy might be manufactured. I do not say this in disparagement of electrostatic generators; on the contrary, I believe that when new types are developed and sufficiently improved a great future will be assured to them.

At first thought it might appear that the performance of such a generator could be doubled by using the free side of the belt for carrying away electricity of opposite sign. In this case the repulsion on one side of the belt would be balanced by the attraction on the other so that, theoretically, the spheres could be charged without expenditure of power. But this is contrary to fundamental laws of nature and it may, therefore, be safely inferred that such a plan would not work.

Static electricity may be eventually harnessed for driving motors and this prospect is attractive on account of the enormous power output of such a machine at very high voltages. The efficient generation and control of these is the chief impediment in this direction. As an interesting experiment the two units of the generator described might be separated and so an electric drive improvised. It would

be operative but inefficient.

While it is quite evident that exceptionally favorable conditions for accurate observation will be realized in this instrument, it is highly probable that the attempts to smash the atomic nucleus and to transmute elements will yield results of doubtful value. Certainly, much of the ingenuity and skill now devoted to these illusionary tasks might be better employed. The nucleus is a neutral body consisting of tightly packed particles of the same kind which were originally positive and negative. When the body is smashed the particles again acquire their charges, without distinction and instantly form neutral pairs so that we have nothing for our pains. It is folly to expect useful results from transmutation brought about through such bombarding of targets. If anything of considerable practical value is ever achieved in this direction it will be by the use of quasi-intelligent agent causing a sorting and regimentation of the particles and their orderly arrangement as required in the formation of a new structure. Such a power is possessed by a catalyst and it will be eventually harnessed and controlled successfully for all sorts of purposes.

Author's note: Reference to pages 252, 253

The required increment of density can be determined by a simple calculation. At the spraying points, due to their constant action, there can be no change in the value 1.8333 found before, but from there on the density will increase and at the very top of the charged area it may be $1.8333 + a$. Since the law of variation is quite immaterial to this argument it may be assumed that the increment is proportionate to the distance from the spraying points, especially as this is most likely to be the case. Under such conditions, a transversal strip of the belt one centimeter long and at a distance X from the center of the sphere, will contain a charge

$q = 120(1.8333+a \frac{d-x}{d-r})$ e.s.u. Hence the repelling force exerted by the charge Q on

the terminal will be $F = \int_r^d Q \times 120(1.8333 + \frac{d-x}{d-r} \frac{dx}{x^2})$ This integral can be readily

solved by expanding and yields the value $F = 2756352 + 1088367a$ dynes. The mechanical work at the normal belt speed of 3000 centimeters per second will, consequently, be equivalent to $W = 0.8269056 + 0.3265101a$ kilowatt seconds and must be equal to the electrical work of the machine with an overflow current of 0.00022 ampere under a tension of 5,000,000 volts; namely, 1.1 kilowatt seconds for each terminal so that

$a = \frac{1.1 - 0.8269056}{0.3265101} = 0.8364$ electro-static units.

With this excess density and distribution of the charge as set forth, the net power of both belts, expressed in electrical units, will be 2.2 kilowatts which is exactly the performance of the generator with the overflow current of 0.00022 ampere and terminal tension of 10,000,000 volts. It is evident that just as water finds its level so this balance is instantly established under all working conditions and is effected by a varying slip of the charge; that is to say, by reduction or increase of its translatory velocity according to the changes of the load.

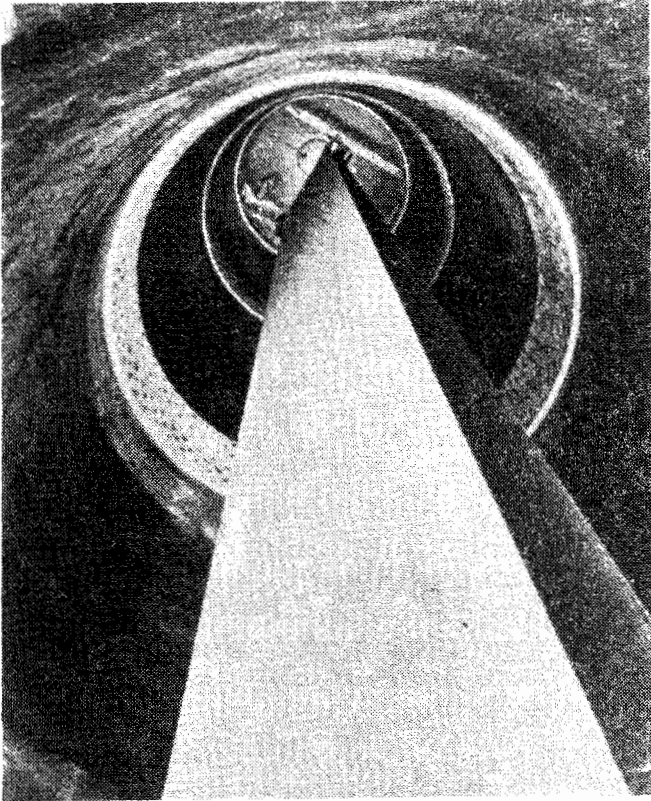

Looking up through one of the insulating columns of the Van de Graaff generator, showing the endless paper belt

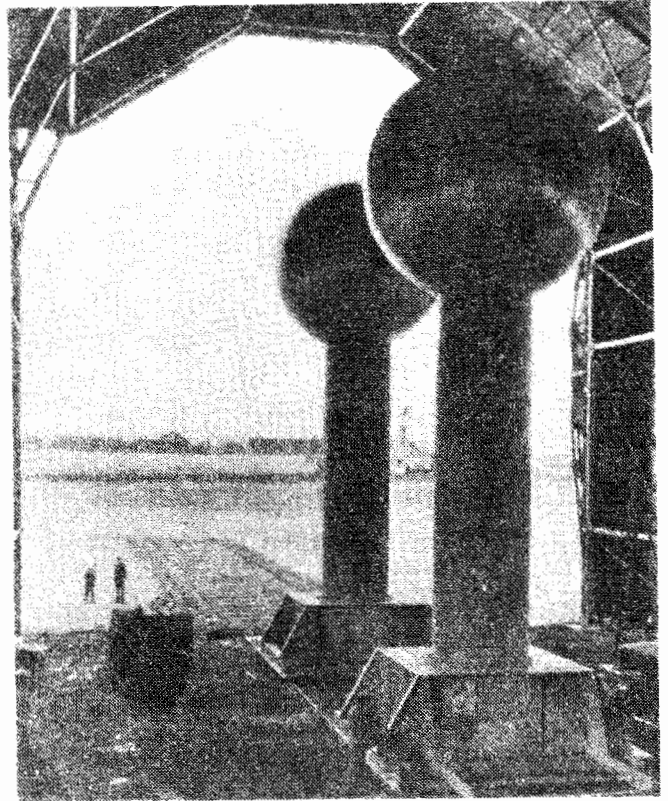

Another view of the high-voltage generator. Tracks are provided so that the equipment may be rolled into the open

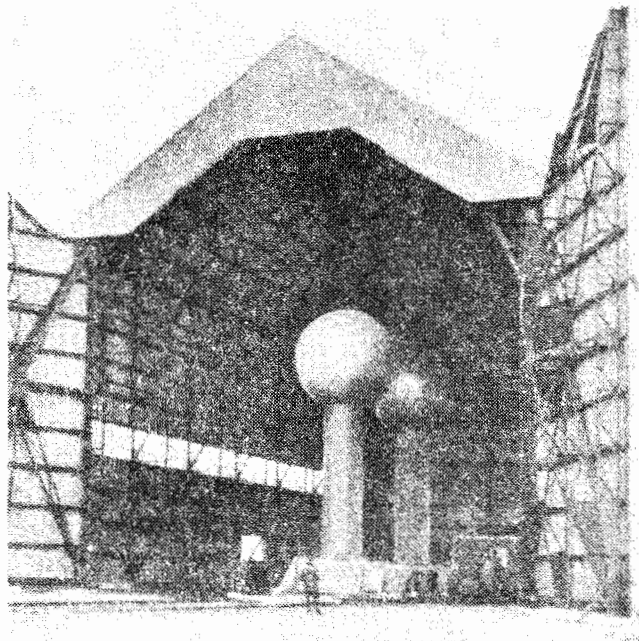

The Van de Graaff generator, shown housed in an aircraft hangar, is discussed by Dr. Tesla in the accompanying article

Scientific American
April, 1934

NIKOLA TESLA WRITES:

Editor, *Scientific American*:

Engineers attach no importance whatever to static electricity generated by belt friction or otherwise. They are apt to dismiss it with the thought that the energy is infinitesimal. That is true. A little water pumped through some joint in a big low-pressure main is of no consequence, but in a pump designed for an extremely high pressure and very small delivery it is all-important. Exactly so in the electrical case. The belt or equivalent device is simply a pump capable of forcing the minute quantity of electricity produced into a condenser against a pressure and increasing the power up to a limit of working capacity of the means employed. Thus mechanical energy, in any desired amount, can be transformed into electric energy yielding direct and constant currents of many millions of volts.

Besides its value as an instrument of research, the Van de Graaff generator will be helpful in stimulating the interest in this neglected field of science and engineering which is of great promise. My comment upon it (Page 132, March, 1934, *SCIENTIFIC AMERICAN*. - *Ed.*) was based on publications in which the device was described in its primitive form. No signal improvements were suggested or mention made of the classical methods for increasing the output. According to the latest report, the normal performance is now 20 kilowatts, from which I infer that the belts are run in a medium under pressure exceeding that of the atmosphere. This is evident since at 10 kilowatts per unit, the density of the charge on the belt, conformably to my calculations, must be about 16.66 at the spraying and 24.27 at the sucking points, which is too high for ordinary conditions. In all probability, an absolute pressure of 30 to 35 pounds per square inch is used to prevent leakage of the moving charge. This method was first resorted to by Hempel in 1885 and more thoroughly investigated by Lehmann in 1891. Other experimenters confirmed these early findings and showed that the output of a static generator is proportionate to the pressure of the gas in which it is operated.

A still better way, also known for many years, is to employ a high vacuum for the same purpose. Both of these methods have their disadvantages. Compression increases proportionately the windage loss, while the vacuum is destructive. The real limit, however, is found in the mechanical strength of the belt and even under the best conditions the performance of such a machine, considering its size, will be small although, by the employment of a Diesel drive, the efficiency might be raised to a satisfactory figure.

The generator, operating with 10,000,000 volts, will accelerate a particle, as the electron, to a speed of 3.662×10^9 centimeters, equal to about 0.122 times that of light, but if projectiles 1800 times heavier are used, as proposed, their striking speed will be only 863 kilometers which is utterly insignificant as compared with that of the cosmic rays.

Nikola Tesla
New York, February 8, 1934

Reprinted with permission. Copyright © 1934 by *Scientific American*, Inc.
All rights reserved.

New York Times

April 8, 1934, Section X, p. 9, col. 1.

TESLA SEES EVIDENCE RADIO AND LIGHT ARE SOUND

An Inventor's Seasoned Ideas

Nikola Tesla, Pointing to 'Grievous Errors' of the Past, Explains Radio as He Sees It at Age of 77 - He Expects Television

By Orrin E. Dunlap, Jr.

A tall, lean inventor in a cutaway walked into his skyscraper parlor thirty-three floors above the sidewalks of New York, laid his black derby on the table, opened the window and then was ready to talk about radio's past, present and future. He was Nikola Tesla, the inventor whose discovery of the rotary magnetic field made possible the alternating current motor. He described a system of wireless transmission of energy in 1892.

Seven milestones beyond three-score and ten, this electrical wizard, who came to America in 1884, looked back across the years, recalled where theorists often chose wrong paths at the crossroads of science and then turned his thoughts to the future in which television lurks.

A Spectacle That Frightens.

"There is something frightening about the universe when we consider that only our senses of sound and sight make it beautiful," said Mr. Tesla as his furrowed brow indicated he is puzzled with its destiny. "Just think, the universe is darker than the darkest ink; colder than the coldest ice and more silent than a silent tomb with all the bodies rushing through it at terrific speeds. What an awe-inspiring picture, isn't it? Yet it is our brain that gives merely a physical impression. Sight and sound are the only avenues through which we can perceive it all. Often I have wondered if there is a third sense which we have failed to discover. I'm afraid not," he said after some hesitation in thought.

Looking back to the mauve decade, to the turn of the century when the world was being thrilled with new ideas and discoveries, Mr. Tesla observes a vast change in the art of invention. Man, he finds, in this streamlined era of speed, has little chance to think.

> Fruits of Seclusion

The big, modern research laboratories are but the incubators of ideas as he has watched them function. Seldom, if ever, he explains, has an original idea of consequence been born in an elaborate laboratory. The egg of science is laid in the nest of solitude. True, it may later be incubated, hatched and nursed in the million dollar laboratory.

"It is providential that the youth or man of inventive mind is not 'blessed' with a million dollars," said Mr. Tesla. "He would find it difficult to think. The mind is sharper and keener in seclusion and uninterrupted solitude. No big laboratory is needed in which to think. Originality thrives in seclusion free of outside influences beating upon us to cripple the creative mind. Be alone, that is the secret of invention; be alone, that is when ideas are born. That is why many of the earthly miracles have had their genesis in humble surroundings."

Radio experimenters of this age are following ancient theories, Mr. Tesla believes, and he warns that progress will be more rapid when they discard the old and adopt the new ideas. His directions for getting on the right track of radio, television and sundry other branches of science follow:

"The fascination of the electro-magnetic theory of light, advanced by Maxwell and subsequently experimentally investigated by Hertz, was so great that even now, although controverted, the scientific minds are under its sway. This theory supposed the existence of a medium which was solid, yet permitted bodies to pass through it without resistance; tenuous beyond conception, and yet, according to our conceptions of mechanical principles and ages of experience, such a medium was absolutely impossible. Nevertheless, light was considered essentially a phenomenon bound up in that kind of a medium; namely, one capable of transmitting transverse vibrations like a solid.

A Question Tesla Asked.

"It is true," said Mr. Tesla, "that many scientific minds envisaged the theory of a gaseous ether, but it was rejected again and again because in such a medium longitudinal waves would be propagated with infinite velocity. Lord Kelvin conceived the so-called contractile ether, possessing properties which would result in a finite velocity of longitudinal waves. In 1885, however, an academic dissertation was published by Prof. De Volson Wood, an American, at a Hoboken institution, which dealt with a gaseous ether in which the elasticity, density and specific heat were determined with rare academic elegance. But, so far, everything pertaining to the subject was purely theoretical."

What, then can light be if it is not a transverse vibration? That was the question he asked himself and set out to find the answer.

"I consider this extremely important," said Mr. Tesla. "Light cannot be anything else but a longitudinal disturbance in the ether, involving alternate compressions and rarefactions. In other words, light can be nothing else than a sound wave in the ether."

This appears clearly, Mr. Tesla explained, if it is first realized that, there being no Maxwellian ether, there can be no transverse oscillation in the medium. The Newtonian theory, he believes, is in error, because it fails entirely in not being able to explain how a small candle can project particles with the same speed as the blazing sun, which has an immensely higher temperature.

"We have made sure by experiment," said Mr. Tesla, "that light propagates with the same velocity irrespective of the character of the source. Such constancy of velocity can only be explained by assuming that it is dependent solely on the physical properties of the medium, especially density and elastic force.

Micro-Wave Possibilities.

Coming now to the wireless waves, it is still true that they are of the same character as light waves, only they are not transversal but longitudinal. As a matter of fact, radio transmitters emit nothing else but sound waves in the ether, and if the experts will realize this they will find it very much easier to explain the curious observations made in the application of these waves.

"It being a fact that radio waves are essentially like sound waves in the air, it is evident that the shorter the waves the more penetrative they would be. In 1899 I produced electromagnetic waves from one to two millimeters long and observed their actions at a distance. There has been a great hope expressed by various workers that introduction of these waves will have a revolutionary effect, but I am not sharing the opinion. They will be used, of course, but to a very limited extent. It is manifest that applications of the very short waves will not produce any appreciable effect upon the wireless art.

"Errors" Retard Wireless Power.

What about the possibilities of power transmission by wireless? the inquirer asked.

Here again Mr. Tesla blames "a strange misconception of the experts" and "grievous errors" for retarding the idea. He believes that when it is accomplished, the power will travel on long waves. He said he could vouch that the scheme of wireless power transmission is entirely practical.

"The application of short waves for power purposes," said Mr. Tesla, "involves complicated and expensive apparatus for rectification or frequency transformation, which would make any serious attempt to carry out a project of this kind much more difficult from an economical point of view."

When will television come around the corner? he was asked.

"It ought to be with us soon, and some day it will be on a par of perfection with broadcasting of music." Then with a circular sweep of his arm and added, "There will be large pictures thrown on the wall."

Modern Mechanix and Inventions
July, 1934

Radio Power will Revolutionize

Tesla's World of Tomorrow

"We are on the threshold of a gigantic revolution, based on the commercialization of the wireless transmission of power.

"Motion pictures will be flashed across limitless spaces . . .

"The same energy (wireless transmission of power) will drive airplanes and dirigibles from one central base.

" . . . In rocket-propelled machines . . . it will be practicable to attain speeds of nearly a mile a second (3600 m.p.h.) through the rarefied medium above the stratosphere.

" . . . We will be enabled to illuminate the whole sky at night . . . Eventually we will flash power in virtually unlimited amounts to planets."

—Nikola Tesla.

THE world will soon enjoy the benefits of electricity transmitted by radio. Huge and expensive transmission lines will be unnecessary. Bulky and unsightly distribution systems will be done away with. A little receiving device in your home will give you all the power you can use—and for only a fraction of present-day costs.

We will soon be communicating with other planets, where it is entirely possible that there is civilization far ahead of ours.

Tomorrow we will see rocket planes flying through stratosphere at a speed of a mile a second or 3600 miles an hour.

Fanciful dreams? No! Just conclusions based upon knowledge of what has been done, what is being done and what can be done in the future. I speak along practi-

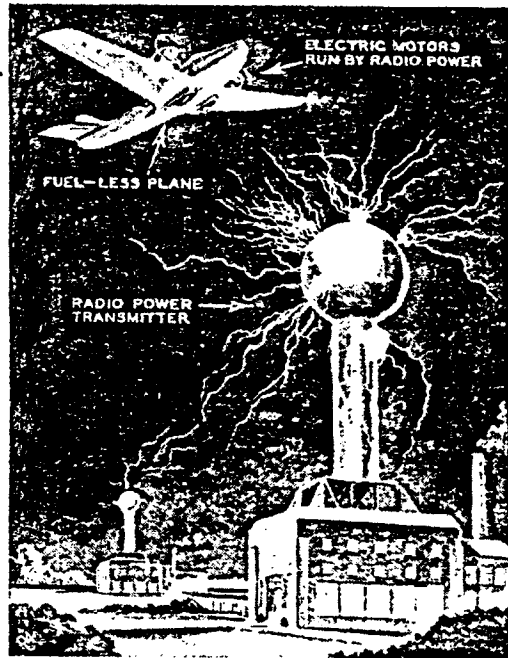

Nikola Tesla, electrical wizard, foresees the day when airplanes will be operated by radio-transmitted power supplied by ground stations, as shown in the drawing above.

cal lines and with a practical knowledge of what I am talking about.

Power transmission by radio is going to change our present civilization materially. The transmission of energy to another planet is now only a matter of engineering. I have solved the problem so well I no longer regard it as doubtful. I am also certain there are creatures on other planets whose ways are like ours. The new era will see amazing developments in interplanetary relations.

Every other planet has to pass through the same phase of existence this earth did, and life is started on them during that favorable phase by the rays of some sun. It develops in the presence of moisture, heat and light in much the same manner as life does here. We know that light propagates in straight lines, and consequently our perceptions of the forms through the images projected on the retina must be true.

Therefore, it should not be hard to establish intelligent exchange of ideas between two

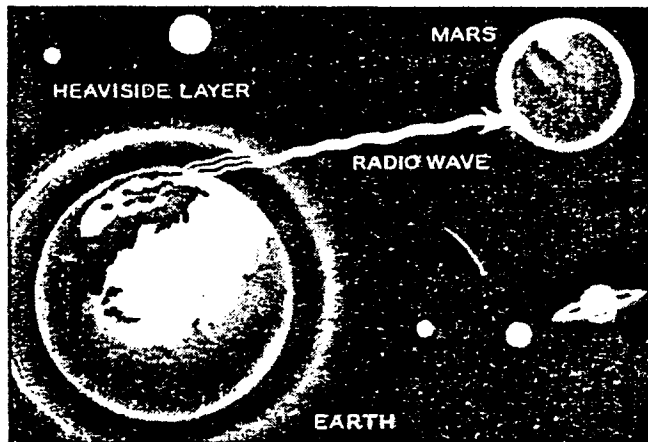

By using ultra-short waves, science expects to penetrate the heaviside layer, or gaseous medium surrounding the earth, and establish radio communication with Mars and other distant planets, as shown in drawing above.

the WORLD

by NIKOLA TESLA

As told to
ALFRED ALBELLI

Who Is Tesla?

Radio Pioneer Nikola Tesla was born in Hungary, came to the United States in 1884 and has since developed more than 100 devices and improvements in electrical technology.

Once associated with the late Thomas A. Edison, Tesla sent a radio impulse around the world almost 40 years ago. He discovered the rotating field principle in alternating currents and is considered one of the greatest living electrical scientists and radio authorities.

planets. The earth we inhabit might be the beneficiary. It is conceivable that there is civilization on other planets far ahead of ours. If communication could be established by the earth the benefits to human beings would be incalculable.

As far back as June, 1900, in discussing my experiments at the beginning of the century, I said that my measurements and calculations showed that it was perfectly practicable to produce on our globe an electrical movement of such magnitude that, without the slightest doubt, its effect would be perceptible on some of our nearer planets, as Venus and Mars.

Interplanetary Communication Probable

Thus, from mere possibility, interplanetary communication has entered the stage of probability. In fact, that we can produce a distinct effect on one of these planets in this novel manner, namely, by disturbing the electrical condition of the earth, is beyond any doubt.

In order to make myself clearer I shall delve still further into the preliminary discoveries made in what I call my pioneering days, which was long before any other scientist had made any progress in this field. I have always chosen to remain in the background.

Some years ago I urged the experts engaged in the commercial application of the wireless art to employ very short waves, but for a long time my suggestions were not heeded. Eventually, though, this was done, and gradually the wave lengths were reduced to but a few meters.

Invariably it was found that these waves, just as those in the air, follow the curvature of the earth and bend around ob-

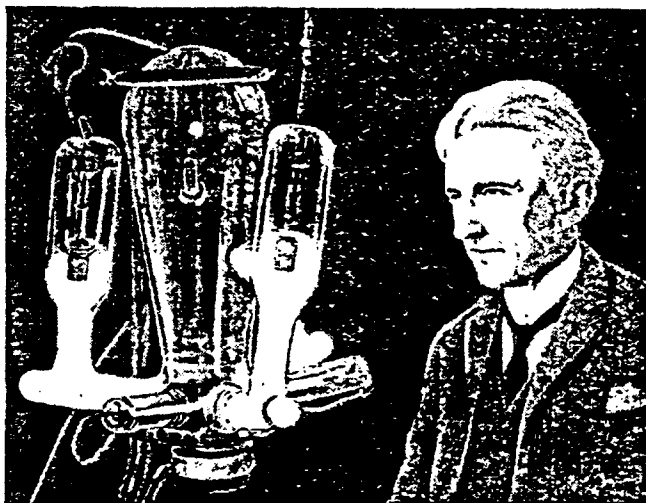

Nikola Tesla is shown in his laboratory with late type mercury arc rectifier tubes. When operating, these tubes give off a violet glow.

stacles, a peculiarity exhibited to a much lesser degree by transverse vibrations in a solid.

Recently, however, ultra-short waves have been experimented with and the fact that they also have that same property was hailed as a great discovery, offering the stupendous promise of making wireless transmission infinitely simpler and cheaper.

It is of interest to know what wireless

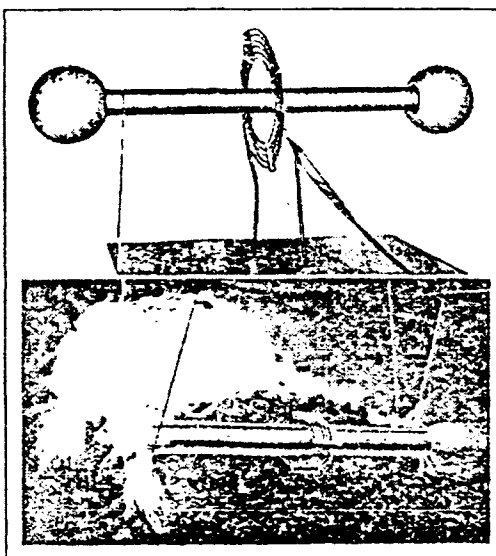

Top photo shows the famous Tesla coil, used to transmit early radio signals. Below, the coil in actual operation.

Rocket Ships to Circle Globe in 5½ Hours; Night to Change Into Day

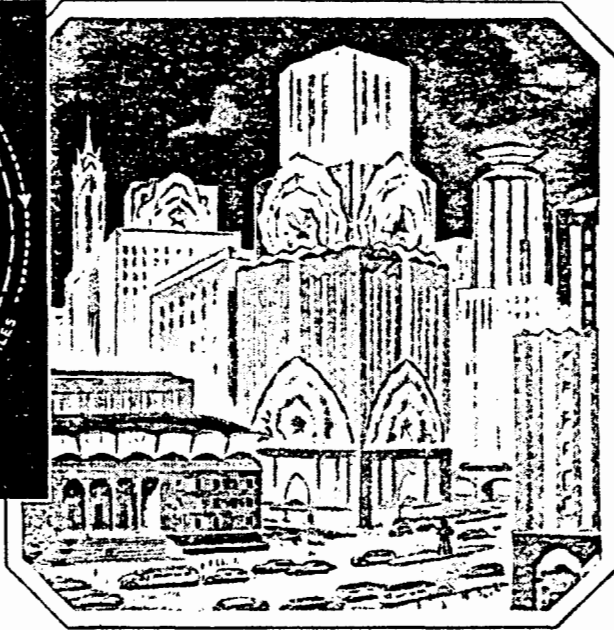

Future rocket planes may circle the globe in 5½ hours. At 3600 m.p.h., the plane travels about 19,500 miles. Earth's rotation adds 5500 miles to total. Right, lights directed against giant reflectors may furnish constant daylight in future, if radio-power projects prove successful.

experts have expected, knowing that waves a few meters long are transmitted clear to the antipodes. Is there any reason that they should behave radically different when their length is reduced to about half of one meter?

As the knowledge of this subject seems very limited, I may state that even waves only one or two millimeters long, which I produced thirty-four years ago, provided that they carry sufficient energy, can be transmitted around the globe. This is not so much due to refraction and reflection as to the properties of a gaseous medium and certain peculiar action.

Short Waves Provide Increased Channels

The chief object of employing very short waves is to provide an increased number of channels required to satisfy the ever-growing demand for radio appliances. But this is only because the transmitting and receiving apparatus, as generally employed, is ill-conceived and not well adapted for selection.

Because of this and other shortcomings, I do not attach much importance to the employment of waves which are now being experimented with. Besides, I am contemplating the use of another principle which I have discovered and which is almost unlimited in the number of channels and in the energy three-electrode tubes.

This invention has been credited to others, but as a matter of fact it was brought out by me in 1892, the principle being transmitted.

It should enable us to obtain many im-

portant results heretofore considered impossible. With the knowledge of the facts before me, I do not think it hazardous to predict that we will be enabled to illuminate the whole sky at night and that eventually we will flash power in virtually unlimited amounts to planets.

I would not be surprised at all if an experiment to transmit thousands of horsepower to the moon by this new method were made in a few years from now. We must establish transmission of power in all its innumerable applications. This has been my life work, and although I am now close to 78, I unhesitatingly say that I hope to see its fruition.

I have been fortunate in the evolution of new ideas, and the thought that a number of them will be remembered by posterity makes me happy indeed. I am confident

(Continued on page 117)

What About Today's Scientists?

"The scientists from Franklin to Morse were clear thinkers and did not produce erroneous theories. The scientists of today think deeply instead of clearly. One must be sane to think clearly, but one can think deeply and be quite insane.

"Today's scientists have substituted mathematics for experiments and they wander off through equation after equation and eventually build a structure which has no relation to reality."

—Nikola Tesla.

Radio Power to Revolutionize World

(Continued from page 12)

that my rotating field and induction motor and the wireless system I have given to the world will live long after I have gone.

You ask me about atomic energy? I experimented with the atom, and achieved similar ends, long before the wave of ballyhoo swept over the country in recent years. The idea of atomic energy is illusionary but it has taken a powerful hold on the mind and there are still some who believe it be realizable.

Tesla's Vacuum Tube

I have disintegrated atoms in my experiments with a high potential vacuum tube I brought out in 1896 which I consider one of my best inventions. I have operated it with pressures ranging from 4,000,000 to 18,000,000 volts. More recently I have designed an apparatus for 50,000,000 volts which should produce many results of great scientific importance.

But as to atomic energy, my experimental observations have shown that the process of disintegration is not accompanied by a liberation of such energy as might be expected from the present theories.

And as for the cosmic ray: I called attention to this radiation while investigating Roentgen rays and radioactivity. In 1899 I erected a broadcasting plant at Colorado Springs, the first and only wireless plant in existence at that time, and there confirmed my theory by actual observation. My findings are in disagreement with the theories more recently advanced.

I have satisfied myself that the rays are not generated by the formation of new matter in space, a process which would be like water running up hill. According to my observations, they come from all the suns of the universe and in such abundance that the part contributed by our own sun is very insignificant by percentage. Some of these rays are of such terrific power that they can traverse through thousands of miles of solid matter.

Properties of Solar Rays

They have, furthermore, other extraordinary properties. This ray, which I call the primary solar ray, gives rise to a secondary radiation by impact against the air and the cosmic dust scattered through space. It is now commonly called the cosmic ray, and comes, of course, equally from all directions in space. If radium could be screened effectively against this ray it would cease to be radioactive.

The scientists from Franklin to Morse were clear thinkers and did not produce erroneous theories. The scientists of today think deeply instead of clearly. One must be sane to think clearly, but one can think deeply and be quite insane.

Today's scientists have substituted mathematics for experiments, and they wander off through equation after equation, and

(Continued on page 118)

I'm Going to Get THAT JOB!



- Accountant & Auditor
- Architect & Builder
- Automotive Engineer
- Business Executive
- Civil Engineer
- Diesel Engineer
- Draftsman & Designer
- Electrical Engineer
- High School Graduate
- Highway Engineer
- Lawyer
- Mechanical Engineer
- Salesman
- Steam Engineer

American School
Dept. GB-23, Drexel Ave.
at 53th St., Chicago, Ill.

Tell me how to qualify for
job checked. No obligation.

Name.....Am.....

Address.....

The Job You Want Means— More Money and Greater Opportunities

Accidents happen—but getting the good job is not an accident and does not just happen. It is a combination of training—experience—and a willingness to use your ability in the interests of your employer.

Every time you apply for a job, you are asked to make out an application stating exactly what training and experience you have to offer. Your record automatically decides the question. So landing the job you want is not so much a question of whether the employment manager likes you personally, but whether your training and experience fit you to fill the position satisfactorily.

Who Will O. K. You for the Job You Want?

Daily we present the qualifications of students and graduates to over 150 employers. We search out openings and O. K. the student as being fitted for the job—all without extra charge. Hundreds have been helped to "cash in" on their training.

Let us help you increase your training, and so get you ready for the job ahead. Promotion is a step-by-step process, and a reasonable amount of extra training will win you an increase of pay several times the cost of the training. And as soon as you are ready, we shall be glad to help you land the coveted position.

It is not an accident that well-trained men secure good positions. Avoid accidents and "play safe" by preparing yourself to fill satisfactorily higher-grade and better-paid positions. Take the first step toward that better-paying job by checking above the kind of work that interests you, and let us send you full information.

American School

Dept. GB23, Drexel Ave. at 53th St., Chicago

THE UNIVERSITY OF THE HOME

NEW LOW PRICES

2 GOOD YEAR
Firestone
Goodrich
U.S. AND OTHERS

THESE TIRES SURE DO LOOK GOOD

YES AND THE YORK GUARANTY BOND PROTECTS YOU

12 MONTH WRITTEN GUARANTY BOND WITH EACH TIRE

LOWEST PRICES ON EARTH

TIRE USERS by thousands all over the U.S.A. vouch for LONG, HARD SERVICE, under severest road conditions of our standard brand Tires reconstructed by the ORIGINAL SECRET YORK PROCESS. OUR 18 YEARS in business makes it possible to offer tires at LOWEST PRICES in history with 12 month guarantee.—Don't Delay—Order Today

BALLOON TIRES

Size	Rim	Tires	Tubes	Size	Rim	Tires	Tubes
29x4.40	-21	\$2.15	\$0.85	30x5.25	-20	\$2.95	1.15
29x4.50	-20	2.35	0.85	31x5.25	-21	3.25	1.15
30x4.50	-21	2.40	0.85	28x5.50	-18	3.35	1.15
28x4.75	-19	2.45	0.95	29x5.50	-19	3.35	1.15
29x4.75	-20	2.50	0.95	30x6.00	-18	3.40	1.15
29x5.00	-19	2.85	1.05	31x6.00	-19	3.40	1.15
30x5.00	-20	2.85	1.05	32x6.00	-20	3.45	1.25
28x5.25	-18	2.90	1.15	32x6.00	-21	3.65	1.25
29x5.25	-19	2.95	1.15	32x6.50	-20	3.75	1.35

REGULAR CORD TIRES

Size	Tires	Tubes	Size	Tires	Tubes
30x3	\$2.25	\$0.65	32x4 1/2	\$3.35	1.15
30x3 1/2	2.35	0.75	33x4 1/2	3.45	1.15
31x4	2.35	0.85	34x4 1/2	3.45	1.15
32x4	2.95	0.85	30x5	3.65	1.35
33x4	2.95	0.85	33x5	3.75	1.45
34x4	3.25	0.85	35x5	3.95	1.55

HEAVY DUTY TRUCK TIRES

Size	Tires	Tubes
30x5 Truck	\$4.25	\$1.95
34x5 Truck	4.25	2.00
32x6 8 ply. Truck	6.95	2.75
32x6 10 ply. Truck	7.95	2.75
36x6 Truck	8.95	3.95
34x7 Truck	9.95	3.25
36x8 Truck	11.45	3.95
40x8 Truck	13.25	4.15

FREE! TIRE GAUGE

SEND ONLY \$1.00 DEPOSIT with each tire ordered. (\$4.00 deposit on each Truck Tire.) We ship balance C.O.D. Deduct 8 per cent if cash is sent in full with order. ALL TUBES BRAND NEW — GUARANTEED. Tires failing to give 12 months' service replaced at half price.

DEALERS WANTED NRA

YORK TIRE & RUBBER CO.
3855-59 Cottage Grove Ave. Dept. 4238, Chicago

HOW TO WIN PRIZE CONTESTS

This book can make you rich, or at least help you make a good living. The purpose of this book, "How to Win Prize Contests," is to help you win by setting forth the best-known principles and methods. Send 25c to HALDEMAN-JULIUS CO. Box 757 GIRARD, KANSAS

COMPLETE ELECTRIC PLANTS



ONAN A.C. PLANTS furnish same current as city service. Operates Radio, Water System and Household Appliances.

\$99

SIZES 300 WATTS UP
Models low at \$99. No battery used. Easy to install. Ideal for farms, lake homes, commercial purposes.

D. W. ONAN & SONS
551 Royallton Ave. Minneapolis, Minn.

Radio Power to Revolutionize World

(Continued from page 117)

eventually build a structure which has no relation to reality.

I work every hour that I am awake but not with a feverish tempo. Although I live in the midst of the hustle and bustle of New York, I do not time my scientific experiments to the hectic, jazz rhythm of the hysterical metropolis. I work for the future—build for the future. Just as today I see the realization of experiments carried on fifty years ago, I am now working with a view toward still greater achievements which will come to pass a half century hence.

That is my method. After experiencing a desire to invent a certain thing, I go on for days, months, even years with the idea in the back of my head. Whenever I feel like it, I play around with the problem without giving it any deliberate consideration. This is the incubation period.

How Tesla Works

Next comes the stage of direct effort. At this point the solution is somewhere in my subconscious mind, although it may take some time before it reaches the level of consciousness.

As my conceived device begins to take form, I make mental changes in the construction, improvements are figured out, and I even operate it. All of this is preliminary work—all in my mind. When the machine itself is finished, I slip my imaginary job over it and find they coincide to the minutest detail.

A great development can be expected in rocket propelled machines for purposes of peace and war. With such machines it will be practicable to attain speeds of nearly a mile a second (3600 miles per hour), through the rarefied medium above the stratosphere.

I anticipate that such machines will be of tremendous importance in international conflicts of the future. I foresee that in times not too distant, wars between various countries will be carried on without a single combatant passing over the border.

Infernal Gas Machines

At this very time it is possible to construct infernal machines which will carry any desired quantity of poison gases and explosives, launch them against a target thousands of miles away and destroy a whole city or community.

If wars are not done away with, we are bound to come eventually to this kind of warfare, because it is the most economical means of inflicting injury and striking terror in the hearts of the enemy that has ever been imagined.

My paramount desire today, which guides me in everything I do, is an ambition to harness the forces of nature for the service of mankind. As I see it, we are on the threshold of a gigantic revolution based on the commercialization of the wireless trans-

Radio Power to Revolutionize World

mission of power. The principles for this have been discovered by me.

As this wireless energy is converted into a commodity for the use of the masses, transport and transmission will be subjected to tremendous changes. Motion pictures will be flashed across limitless spaces by my system. The same energy will drive airplanes and dirigibles from one central base.

In this new era man will be able to travel safely, and at great speed, to any part of the world—the jungle—the arctic—the desert—mountain tops—over oceans. The instruments by which these wonders will be achieved will be amazingly simple.

These things will come to pass. Some of them are already within the realm of realization. But like those wonders which I predicted and helped perfect nearly fifty years ago—in the early 80's—power transmission is just around the corner. It's coming.

Today I repeat again what I said to contemporary scientists of those earlier pioneering days:

The scientific man does not aim at an immediate result. He does not expect that his advanced ideas will be readily taken up. His work is like that of the planter—for the future. His duty is to lay the foundation for those who are to come, and point the way. He lives and labors and hopes.

How President Roosevelt Keeps Fit

(Continued from page 65)

est in the outdoors than the present President. Before illness robbed him of the full use of his legs he was an all-around athlete, enjoying tennis, hunting, iceboating, swimming, baseball and football.

But although the President's enormous energy is geared to the production peak of a precision-tooled machine, he does not allow his energy to run away with him. He knows when to work and when to rest—a lesson brought home to him in force when in 1921 paralysis struck him down. Deprived of the use of both his arms and his legs and given scant aid from physicians who knew next to nothing about his disease, Roosevelt was forced to work out his own salvation. His subsequent victory was two-fold: physical recovery and a basic knowledge of mental discipline.

Today, a great part of the President's health program is given over to mental relaxation. He is a great reader, enjoys moving pictures, likes to listen to the radio and is enthusiastic about music, both popular and classical tunes.

Indoor games are one of the President's favorite methods of relieving mental pressure. He enjoys rummy, solitaire, bridge and parchesi, playing them all with his characteristic gusto, but never worrying about their outcome. The President is also one of America's leading hobbyists. His stamp collection is noteworthy and his group of ship models and naval paintings and lithographs is one of the most extensive in existence.

AIR CONDITIONING

THE NEXT BIG INDUSTRY

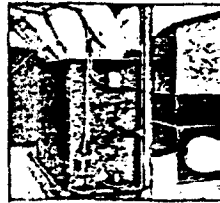

Its opportunities are as big in winter as in summer. Plumbing and heating engineers must know Air Conditioning—the field in its broader aspects invites ambitious men. Write for information on the new, up-to-the-minute course on Air Conditioning now offered by the International Correspondence Schools.

... INVENTION—a field of opportunity for men with ideas

If you have an inventive turn of mind, this new International Correspondence Schools Course in inventing and patenting will teach you all the basic knowledge you must have in order to earn real money from your talents. The coupon will bring full information.



CHEMISTRY—a career of service and profit

No field of human endeavor offers greater possibilities today than chemistry. All progress is dependent upon this fascinating science. And right at home, in spare time, you can learn the fundamentals by study of the International Correspondence Schools modern course. Today, ask us for complete information. Send for an interesting booklet—free.



RADIO holds great rewards for trained men

Almost in a decade radio has become a giant industry. The opportunities created will be enjoyed by trained men. The International Correspondence Schools Radio Course, prepared by leading authorities and constantly revised, will make you a trained man! A fascinating book—FREE. Mail the coupon.



INTERNATIONAL CORRESPONDENCE SCHOOLS

Box 2322-X, Scranton, Penna.

Without obligation, send me full information on subject checked below:

- | | |
|--------------------------------------------------|-----------------------------------------------|
| <input type="checkbox"/> Air Conditioning | <input type="checkbox"/> Chemistry |
| <input type="checkbox"/> Inventing and Patenting | <input type="checkbox"/> Radio |
| <input type="checkbox"/> Architecture | <input type="checkbox"/> Highway Engineering |
| <input type="checkbox"/> Concrete Construction | <input type="checkbox"/> Poultry Farming |
| <input type="checkbox"/> Mechanical Engineering | <input type="checkbox"/> Drafting |
| <input type="checkbox"/> Reading Shop Blueprints | <input type="checkbox"/> Accounting |
| <input type="checkbox"/> Civil Engineering | <input type="checkbox"/> Good English |
| <input type="checkbox"/> Electrical Engineering | <input type="checkbox"/> Salesmanship |
| <input type="checkbox"/> Diesel Engines | <input type="checkbox"/> Advertising |
| <input type="checkbox"/> Gas Engine Operating | <input type="checkbox"/> Show Card Lettering |
| <input type="checkbox"/> Refrigeration | <input type="checkbox"/> Civil Service |
| <input type="checkbox"/> Aviation Engines | <input type="checkbox"/> High School Subjects |

Name _____

Address _____

New York Times

Oct. 21, 1934, Sec. IV, p. 5, col. 4,5.

TRIBUTE TO KING ALEXANDER

To The Editor of The New York Times:

Much has been said about Yugoslavia and its people, but many Americans may be under a wrong impression for political enemies and agitators have spread the idea that its inhabitants belong to different nations animated by mutual hate and held together against their will, by a tyrannical power. The fact is that all Yugoslavs - Serbians, Slavonians, Bosnians, Herzegovinians, Dalmations, Montenagrins, Croats and Slovenes - are of the same race, speak the same language and have common national ideals and traditions.

At the termination of the World War, Alexander brought about a political union creating a powerful and resourceful State. This was hailed with joy by all the Slavs of the Balkans, but it took time before the people found themselves in the new conditions.

Serbs Did the Fighting.

I was born in Croatia. The Croats and Slovenes were never in a position to fight for their independence. It was the Serbians who fought the battles for freedom and the price of liberty was paid in Serbian blood. All true Croats and Slovenes remember that gratefully. They also know that the Serbians have an unequalled aptitude and experience in warfare and are best qualified to direct the forces of the country in a crisis.

Ever since united Yugoslavia came into being through Alexander's efforts, political enemies have done all they could to disrupt it by sowing seeds of discord and disseminating malicious reports. An instance of the kind is a book by Louis Adamic, "The Native's Return," which he is supposed to have written under the provisions of the Guggenheim award for literature and in which he indulges in political defamation, denunciation of the ruler of the country and promulgation of ideas as unwelcome here as in Yugoslavia.

His denunciations of the King and reflections on his character can be contemptuously passed, but one thing cannot be ignored. The book contains statements representing the great and fearless man, who has led his people in sanguinary battles, as a weakling in mortal fear of assassination, so much so that he retired every night to a different room and did not show himself until hundreds of his aides had cleared the place and made safe his appearance. This has cut deep into the heart of every loyal Yugoslav.

Dissensions Denied.

Mr. Adamic is very loud in telling of the hatred and dissensions between Croats and Slovenes and the Serbians, but recent events have disproved his statements. The countries, which according to his accounts, should be in open revolt, have shown themselves as devoted to the King of Serbia. This has been reflected in several reports of The New York Times, among which is the extraordinarily vivid and dramatic description of the obsequies.

The death of the King has shaken the country to its very foundations, but the enemies who say that it means the disruption of Yugoslavia will hope in vain, for the noble blood of the great man has only served to cement its parts more firmly and strengthen the national structure. Alexander will live long in the memory of his people, a heroic figure of imposing stature, both the Washington and Lincoln of the Yugoslavs; like Washington an able and intrepid general who freed his country from oppression; like Lincoln a wise and patriotic leader who suffered martyrdom.

Nikola Tesla, New York, Oct. 19, 1934

New York Herald Tribune
March 3, 1935

GERMAN COSMIC RAY THEORY QUESTIONED

Nikola Tesla Doubts Link Between Rays and Outburst of Nova Herculis. Inventor Says Light and Particles do Not Travel at the Same Speed.

By Nikola Tesla

The Herald Tribune of January 20, 1935, contained a report relating to some observations of cosmic rays made by Dr. Werner Kolhoester, director of the Observatory of Potsdam, in connection with the outburst of Nova Herculis (the "new" star) noted in December of last year. I had intended to offer a few words of comment upon the same at that time, but thought it advisable to read first the original statement published in the Supplement of the "Berliner Tageblatt" of January 20, 1935, which has been forwarded to me through the courtesy of the German Consulate.

Would Confirm His Theory

This news item has interested me, as the results announced, if valid, would be another confirmation of my theory of cosmic rays advanced in 1896 according to which these radiations can only emanate from such vast and incandescent heavenly bodies as our sun, placed in an almost perfect vacuum and charged to tremendous potentials, sufficient for imparting to minute similarly electrified particles immense speeds and energies by electrostatic repulsion. I have proved this theory rigorously by experiments and deductions, but had I not done so, it would still be established as a scientific truth, for there is no force or effect produced in the universe which, even if amplified millions of times, could account for the cosmic phenomena discovered by me.

Now, a Nova, in its phase of greatest brightness and transcending temperature at the surface, is a generator of cosmic rays incomparably more powerful than our sun. But while this is unquestionably true, the findings of the German radiologist are open to serious objections.

In the first place, calculation conformable to my theory shows that in order to cause an increase in the intensity of the rays of the order found, the surface temperature of the star, assuming its distance 1,200 light years, could not have been much less than 5,000,000 degrees centigrade. Such a high value is extremely improbable although in a Nova, in which radiation of heat from the inside is greatly facilitated by expansion, the difference in the temperatures of the central and peripheral parts may not be very great.

Then, again, the increase recorded, amounting to about 1 percent of the intensity of cosmic rays emitted by our sun, is too small for drawing a reliable conclusion in view of the influence of weather conditions and other disturbing causes. It must also be borne in mind that the coincidence method adopted is far from being accurate.

There exists, however, an element of incertitude which in itself is sufficient to invalidate completely the results obtained and of which Dr. Kolhoester does not seem to have thought. Light is a wave motion of definite velocity, determined by the elastic force and density of the medium. Cosmic rays are particles of matter, the speed of which depends on the propelling force and mass and may be much smaller or greater than that of light.

Difference in Speeds

Consequently, there can be no concordance in the phases of the two disturbances at the place of observation. The cosmic rays, generated during the maximum brightness of the star, may reach the place many centuries sooner or later than the light,

according to their speed. It thus appears that the results announced cannot have been due to Nova Herculis. Considering further the briefness and small number of star outbursts, it is evident that the Novae cannot contribute appreciably to the steady rain of cosmic particles pouring upon the earth from the countless suns of the universe.

Detroit Times

Sept. 22, 1935, p. 3.

NIKOLA TESLA TELLS HOW HE'D DEFEND ETHIOPIA AGAINST ITALIAN INVASION

Dense Tropical Growth Will Frustrate Bombs and Gas Hurlled from Airplane.

By Nikola Tesla - World Famous Scientist and Discoverer in the Field of Modern Electrical Invention. In an Interview With George Sylvester Viereck.

"What would you do, if you were Emperor of Ethiopia?"

This question, addressed to Nikola Tesla, suggested itself to me when I remembered the recent announcement by the discoverer of the rotating electric field, that he had perfected certain inventions by which the weak could protect themselves against the strong.

These inventions, it was claimed, could destroy whole cities and put an attacking fleet of airplanes out of commission at great distance.

Could these means be employed by Ethiopia to hold off Mussolini?

I sought out the inventor in a skyscraper hotel, where he ponders over new scientific devices.

Tesla was deeply absorbed in thought, but his sternness melted and his pale face was illuminated by an understanding smile.

"Why do you ask me this question? I bear no ill will against Italians; they have brought forth great men in science, literature and art, and supplied workmen and artisans who have advanced humanity.

"This alleviates their contemplated act of piracy. Other nations have done worse. Nations cannot be judged by the same standards as individuals.

"If I were the ruler of Ethiopia, I would rigorously utilize every natural advantage of my country to nullify the effectiveness of this superior armament and, above all, to prevent him from staging a sensational air-attack, destructive to the morale of my simple-minded subjects.

MUST USE THEIR WITS.

"As a first and absolutely indispensable measure I would order the complete evacuation of Addis Ababa and all other places of importance without a moment's delay. I believe that Haile Selassie already contemplates some such course.

"I would leave no civilians behind in dealing with Mussolini. Though a man of genius and culture, the Duce has a strain of ferocity in his make-up, which appears in some of his outbursts. Savagely bent upon avenging the crushing Italian defeat at Adowa, Mussolini would command ruthless destruction.

"I would scatter my people in the thickly wooded regions and tell them that they must match with cunning what they lack in might to escape annihilation.

"Italian air fleets will darken the sky to overawe the population, probably. But will they bomb towns and settlements, deserted and stripped of all things of value?

That would be a costly sport. It would incur the scorn and ridicule of the world. If my directions were strictly followed, the Italian airman could never find the Ethiopian in the tropical underbrush."

"Knowing that the Ethiopians are hidden there, would the Italians not scatter their bombs over their forests?"

"The noise of bombs hurled from airplanes under such conditions would be entirely out of proportion to their destructiveness; they would kill very few people," Tesla replied with a laugh.

"The dense tropical growth is an ideal impediment against gases and bombs and greatly reduces the range of such devices. Remember also that Ethiopia has a surface of 350,000 square miles, and a population of only 10,000,000, or, on the average 25 inhabitants per square mile. Even to clean out an insignificant jungle requires thousands of ordinary bombs."

"But if the Italians resort to poison gas, what then?"

POISON GAS CERTAIN TO FAIL.

"Such attacks must fail. It is a common mistake to disregard the character of the terrain in estimating the military value of modern arms.

"Weapons that could be used with disastrous results in Europe, will prove futile in Ethiopia. Poison gas is released by bursting bombs or sprinkled from reservoirs. The weight of these gases is insignificant compared with that of the containers and accessories required for their transportation. To provide 1,000 cubic feet of gas, a plane must carry equipment weighing one ton, and 1,000 cubic feet of gas is no more than a drop in a barrel.

"If I were the King, I would teach my subjects how to render themselves immune to poison gas. To explain the scheme, I must go back to my young days in Yugoslavia. As a boy I was very fond of running against the wind and observed that in the summer there was a steady breeze from the land covered with vegetation to a desolate region, barren of growth and strewn with rocks.

"'Why does the wind always blow that way?' I asked my mother. 'Because God has willed it so, my boy.' 'But why has God willed it so?' My curiosity was not satisfied until I acquired some knowledge of physics and mechanics.

"Then I understood that the bleak region exposed to the direct glare of the sun became very hot. The expanded air rose, reducing the static pressure. Then, the cooler and denser air from the surrounding country rushed in, to be in turn heated and caused to rise.

PREVAILING WINDS DISPEL GASES.

"In Ethiopia, where the thermometer registers as much as 140 degrees in the shade, the exposed regions attain scorching heat and the ensuing air-current is swift and of large volume.

"Travelers, noting the prevalence of winds, have not attached any significance to them. Yet, here lies the salvation of Ethiopia. These winds are of supreme importance in gas war. They dilute the gases very greatly and quickly and at the same time supply the vivifying oxygen.

"If I were Haile Selassie, I would station my subjects behind natural or artificial barriers sheltering them from the wind. The gas, released in front of them, will be rendered innocuous, because it will be carried off by the wind from which they are protected. The gas released behind them will be extremely diluted. Streaming past the barrier, it will cause little harm.

"Perhaps my suggesting this remedy in my wholly hypothetical role, I may be

rendering a service to both combatants.

"But the Italians have been preparing long for this war; they may spring surprises. It was reported that their chemists have produced a powder which will burn the feet of the Ethiopians and put them out of combat.

"That must be the proposition of a practical joker or an ignoramus. It would not be possible to manufacture 1 percent of the powder necessary for this purpose. If a limited quantity were sprinkled on the roads and pathways, the Ethiopians would soon find out and beware.

"In my opinion the Italians will be wise to abstain from the use of poison in any form. The natives could retaliate by poisoning all wells. This kind of warfare could not fail to prove a calamity; it would bring about a holocaust among the animals. Their putrifying bodies would bring on pestilence. Water would carry the germ-infection far and wide.

"No, I do not think that the Ethiopians will be in danger from such devices. The airplane will be of value only in open battle and for scouting purposes. It is not a peril to the Ethiopians.

"Their greatest peril is their own impetuosity. If they permit themselves to be detected and enveloped, if they do not confine themselves entirely to guerrilla tactics, the Italians will smash them."

"Have you thought of tanks? How would you meet that menace?"

"I admit, the task is not easy. The modern tank may be compared to the rhinoceros in the days when no bullet could pierce its hide. The heavy armor of the vehicle protects it from guns of considerable calibre.

MERCURIC FULMINATE TO PIERCE TANKS.

"But this would not discourage me, if I were the Lion of Judah. Under my guidance and the pressure of necessity my few mechanical and chemical experts would quickly perfect an efficient defense - possibly rifles of large bore, adapted to fire charges of mercuric fulminate.

"This is an extraordinarily powerful explosive. The extreme suddenness of its detonation is such that, even if unconfined, it will punch a hole in a thick steel plate.

"The chief difficulty is to prevent premature explosion of the gun barrel. I think this could be overcome by an elastic resistance and slow acceleration, which is practicable as the range can be short.

"The charges exploding in contact with the tank would put the propelling engines and machine gun equipment out of order. My Ethiopians, sallying forth from ambush, would do the rest."

"What will be the outcome of the war - if it comes to pass?"

"This question is easily answered. The Ethiopians must hide in the day and strike in the dark. In doing so, they can prevent the aggressors from achieving the important military results during the present dry season. When the rain comes again, their battle will be half won.

ITALIANS ALWAYS POOR COLONIZERS.

"But we are dealing with a hypothesis. I am still convinced that Mussolini will not dare to embark upon a large-scale invasion of Ethiopia. The price he must pay in equipment and men is too great. He must envisage disastrous consequences to Italy, even in case of victory.

"Should Ethiopia be conquered, it would prove a cancer eating away the substance

of Italy. The Italians have never been successful colonizers.

"I perceive more and more clearly that Mussolini is making bold gestures to attain valuable concessions through the mediation of the Peace Conference.

"Holding over the heads of the spineless League of Nations, like a sword of Damocles, the threat of another World War more frightful than the first, he has succeeded in scaring its members, so that they are making ready to deal unfairly with a nation whose only offense is its weakness - a nation that existed before Romulus and Remus were born and maintained its independence for over three thousand years.

"No matter what compromises may be adopted the Ethiopians will rather die than surrender their independence; hence, whether the issue be peace or war, there is much trouble ahead."

Prepared Statement by Nikola Tesla
July 10, 1937 (Prior to interviews with the press on his 81st birthday observance.)

At the close of 1889, having worked one year in the shops of George Westinghouse, Pittsburgh, I experienced so great a longing for resuming my interrupted investigations that, notwithstanding a very tempting proposition by him, I left for New York to take up my laboratory work. But owing to pressing demands by several foreign scientific societies I made a trip to Europe where I lectured before the Institution of Electrical Engineers and Royal Institution of London and the Societe de Physique in Paris. After this and a brief visit to my home in Yugoslavia I returned to this country in 1892 eager to devote myself to the subject of predilection on my thoughts: the study of the universe.

During the succeeding two years of intense concentration I was fortunate enough to make two far-reaching discoveries. The first was a dynamic theory of gravity, which I have worked out in all details and hope to give to the world very soon. It explains the causes of this force and the motions of heavenly bodies under its influence so satisfactorily that it will put an end to idle speculations and false conceptions, as that of curved space. According to the relativists, space has a tendency to curvature owing to an inherent property or presence of celestial bodies. Granting a semblance of reality to this fantastic idea, it is still self-contradictory. Every action is accompanied by an equivalent reaction and the effects of the latter are directly opposite to those of the former. Supposing that the bodies act upon the surrounding space causing curvature of the same, it appears to my simple mind that the curved spaces must react on the bodies and, producing the opposite effects, straighten out the curves. Since action and reaction are coexistent, it follows that the supposed curvature of space is entirely impossible. But even if it existed it would not explain the motions of the bodies as observed. Only the existence of a field of force can account for them and its assumption dispenses with space curvature. All literature on this subject is futile and destined to oblivion. So are also all attempts to explain the workings of the universe without recognizing the existence of the ether and the indispensable function it plays in the phenomena.

My second discovery was a physical truth of the greatest importance. As I have searched the scientific records in more than half dozen languages for a long time without finding the least anticipation, I consider myself the original discoverer of this truth, which can be expressed by the statement: There is no energy in matter other than that received from the environment. On my 79th birthday I made a brief reference to it, but its meaning and significance have become clearer to me since then. It applies rigorously to molecules and atoms as well as the largest heavenly bodies, and to all matter in the universe in any phase of its existence from its very formation to its ultimate disintegration.

Being perfectly satisfied that all energy in matter is drawn from the environment, it was quite natural that when radioactivity was discovered in 1896 I immediately started a search for the external agent which caused it. The existence of radioactivity was positive proof of the existence of external rays. I had previously investigated various terrestrial disturbances affecting wireless circuits but none of them or any others emanating from the earth could produce a steady sustained action and I was driven to the conclusion that the activating rays were of cosmic origin. This fact I announced in my papers on Roentgen rays and Radiations contributed to the Electrical Review of New York, in 1897. However, as radioactivity was observed equally well in other widely separated parts of the world, it was obvious that the rays must be impinging on the earth from all directions. Now, of all bodies in the Cosmos, our sun was most likely to furnish a clue as to their origin and character. Before the electron theory was advanced, I had established that radioactive rays consisted of particles of primary matter not further decomposable, and the first question to answer was whether the sun is charged to a sufficiently high potential to produce the effects noted. This called for a prolonged investigation which culminated in my finding that the sun's potential was 216 billions of volts and that all such large and hot heavenly bodies emit cosmic rays. Through further solar research and observation of Novae this has been proved conclusively, and to deny it would be like denying the light and heat of the sun. Nevertheless, there are still some doubters who prefer to shroud the cosmic rays in deep mystery. I am sure that this is not true for there is no place where such a process occurs in this or any other universe beyond our ken.

A few words will be sufficient in support of this contention. The kinetic and potential energy of a body is the result of motion and determined by the product of its mass and the square of velocity. Let the mass be reduced, the energy is diminished in the same proportion. If it be reduced to zero the energy is likewise zero for any finite velocity. In other words, it is absolutely impossible to convert mass into energy. It would be different if there were forces in nature capable of imparting to a mass infinite velocity. Then the product of zero mass with the square of infinite velocity would represent infinite energy. But we know that there are no such forces and the idea that mass is convertible into energy is rank nonsense.

While the origin and character of the rays observed near the earth's surface are sufficiently well ascertained, the so-called cosmic rays observed at great altitudes presented a riddle for more than 26 years, chiefly because it was found that they increased with altitude at a rapid rate. My investigations have brought out the astonishing fact that the effects at high altitudes are of an entirely different nature, having no relation whatever to cosmic rays. These are particles of matter projected from celestial bodies at very high temperature and charged to enormous electrical potentials. The effects at great elevations, on the other hand, are due to waves of extremely small lengths produced by the sun in a certain region in the atmosphere. This is the discovery which I wish to make known. The process involved in the generation of the waves is the following: The sun projects charged particles constituting an electric current which passes through a conducting stratum of the atmosphere approximately 10 kilometers thick enveloping the earth. This is a transmission of energy exactly as I illustrated in my experimental lectures in which one end of a wire is connected to an electric generator of high potential, its other end being free. In this case the generator is represented by the sun and the wire by the conducting air. The passage of the solar current involves the transference of electric charges from particle to particle with the speed of light, thus resulting in the production of extremely short and penetrating waves. As the air stratum mentioned is the source of the waves it follows that the so-called cosmic rays observed at great altitudes must increase as this stratum is approached. My researches and calculations have brought to light the following facts in this connection: (1) the intensity of the so-called cosmic rays must be greatest in the zenithal portion of

atmosphere; (2) the intensity should increase more and more rapidly up to an elevation of about 20 kilometers where the conducting air stratum begins; (3) from there on the intensity should fall, first slowly and then more rapidly, to an insignificant value at an altitude of about 30 kilometers; (4) the display of high potential must occur on the free end of the terrestrial wire, that is to say, on the side turned away from the sun. The current from the latter is supplied at a pressure of about 216 billion volts and there is a difference of 2 billion volts between the illuminated and the dark side of the globe. The energy of this current is so great that it readily accounts for the aurora and other phenomena observed in the atmosphere and at the earth's surface.

For the time being I must content myself with the announcement of the salient facts, but in due course I expect to be able to give more or less accurate technical data relating to all particulars of this discovery.

To go to another subject, I have devoted much of my time during the year to the perfecting of a new small and compact apparatus by which energy in considerable amounts can now be flashed through interstellar space to any distance without the slightest dispersion. I had in mind to confer with my friend George E. Hale, the great astronomer and solar expert, regarding the possible use of this invention in connection with his own researches. In the meantime, however, I am expecting to put before the Institute of France an accurate description of the devices with data and calculations and claim the Pierre Guzman Prize of 100,000 francs for means of communication with other worlds, feeling perfectly sure that it will be awarded to me. The money, of course, is a trifling consideration, but for the great historical honor of being the first to achieve this miracle I would be almost willing to give my life.

My most important invention from a practical point of view is a new form of tube with apparatus for its operation. In 1896 I brought out a high potential targetless tube which I operated successfully with potentials up to 4 million volts from '96 to '98. This device was adopted by many imitators and with slight modifications it is employed even now in all research laboratories and scientific institutions here and in other countries, and virtually all atomic investigations are carried on with it. At a later period I managed to produce very much higher potentials up to 18 million volts, and then I encountered unsurmountable difficulties which convinced me that it was necessary to invent an entirely different form of tube in order to carry out successfully certain ideas I had conceived. This task I found far more difficult than I had expected, not so much in the construction as in the operation of the tube. For many years I was baffled in my efforts, although I made a steady slow progress. Finally though, I was rewarded with complete success and I produced a tube which it will be hard to improve further. It is of ideal simplicity, not subject to wear and can be operated at any potential, however high, that can be produced. It will carry heavy currents, transform any amount of energy within practical limits, and it permits easy control and regulation of the same. I expect that this invention, when it becomes known, will be universally adopted in preference to other forms of tubes, and that it will be the means of obtaining results undreamed of before. Among others, it will enable the production of cheap radium substitutes in any desired quantity and will be, in general, immensely more effective in the smashing of atoms and the transmutation of matter. I am hopeful that it will be possible by its use to carry out a process in which there should be no misses whatever, but only hits. However, this tube will not open up a way to utilize atomic or subatomic energy for power purposes. According to the physical truth I have discovered there is no available energy in atomic structure, and even if there were any, the input will always greatly exceed the output, precluding profitable, practical use of the liberated energy.

Some papers have reported that I had promised to give a full description of my

tube and its accessories on the present occasion. This has caused me a considerable annoyance as, owing to some obligations I have undertaken regarding the application of the tube for important purposes, I am unable to make a complete disclosure now. But as soon as I am relieved of these obligations a technical description of the device and of all the apparatus will be given to scientific institutions.

There is one more discovery which I want to announce at this time, consisting of a new method and apparatus for the obtainment of vacua exceeding many times the highest heretofore realized. I think that as much as one-billionth of a micron can be attained. What may be accomplished by means of such vacua is a matter of conjecture, but it is obvious that they will make possible the production of much more intense effects in electron tubes. My ideas regarding the electron are at variance with those generally entertained. I hold that it is a relatively large body carrying a surface charge and not an elementary unit. When such an electron leaves an electrode of extremely high potential and in very high vacuum, it carries an electrostatic charge many times greater than the normal. This may astonish some of those who think that the particle has the same charge in the tube and outside of it in the air. A beautiful and instructive experiment has been contrived by me showing that such is not the case, for as soon as the particle gets out into the atmosphere it becomes a blazing star owing to the escape of the excess charge. The great quantity of electricity stored on the particle is responsible for the difficulties encountered in the operation of certain tubes and the rapid deterioration of the same.

Nikola Tesla

(The following article has been included in conjunction with the previous prepared statement by Nikola Tesla - Ed.)

New York Times

July 11, 1937, p. 13, col. 2.

SENDING OF MESSAGES TO PLANETS PREDICTED BY DR. TESLA ON BIRTHDAY

Inventor, 81, Talks of Key to Interstellar Transmission and Tube to Produce Radium Copiously and Cheaply - Decorated by Yugoslavia and Czechoslovakia.

Reports of discoveries by which it will be possible to communicate with the planets and to produce radium in unlimited quantity for \$1 a pound were announced by Dr. Nikola Tesla yesterday at a luncheon on his eighty-first birthday at which he was honored with high orders from the Yugoslav and Czechoslovak Governments.

Dr. Tesla, whose discoveries in electrical science have won for him recognition as the father of modern methods of generating and distributing electrical energy, asserted his "absolute" belief that he would win the Pierre Guzman prize of the Institute of France for his discovery relating to the instellar transmission of energy.

Following his annual custom, Dr. Tesla played host to a group of newspaper men at his birthday luncheon at the Hotel New Yorker and issued the announcement of his discoveries of the last year. No apparatus or sketches were shown, but Dr. Tesla said in announcing perfection of the principle of a new tube, which he said would make it possible to smash the atom and produce cheap radium, that he would be able to give a demonstration in "only a little time."

Guests at Dr. Tesla's luncheon included Constantin Fotitch, Minister from Yugoslavia; Vladimir Hurban, Minister from Czechoslovakia; R. Petrovich, first secretary of the Yugoslav delegation; B. P. Stoyanovitch, Yugoslav Consul General in New York; Dr. J. Nemeck, counselor of the Czechoslav Legation, and J. Hajny, Acting Consul General in New York for Czechoslovakia.

Presenting to Dr. Tesla the Grand Cordon of the White Eagle, highest order of Yugoslavia, Mr. Fotitch announced it was the first time the order had been granted to an American for civil accomplishments. The honor was bestowed by order of King Peter through the Regent, Prince Paul.

Dr. Tesla's career has been an inspiration to the youth of his native country, the Minister said. Evidently referring to Dr. Tesla's report several years ago of inventing a "death beam" for use as a defense weapon, the Minister said:

"All your efforts are directed to find a way, by means of some new magic invention of yours, by which you will check and render futile as much as possible all those inventions which men have invented to destroy mutually one another. You feel, as we all feel in your old country, that the world has seen enough of horror and that after so many examples of heroism displayed in the Great War, humanity has found a better way only in peace."

Mr. Hurban, presenting the Grand Cordon of the White Lion, which has been granted to such other distinguished Americans as Secretary Kellogg, Elihu Root and Dr. Nicholas Murray Butler, said "our Czechoslovak nation's brotherly feeling toward you as a son of Yugoslavia made it a duty, not a privilege, to give you this decoration in the name of the president of our nation, Dr. Eduard Benes." He also presented a diploma certifying Dr. Tesla's honorary degree as a doctor of the University of Prague.

Outlines His Discoveries

Dr. Tesla, in responding, said he considered Czechoslovakia "one of the most

enlightened countries in the world."

In a ten-page typewritten statement outlining his discoveries, Dr. Tesla gave a resume of his work in the fields of gravity and cosmic rays. Asserting that "the so-called cosmic rays observed at great altitudes presented a riddle for more than twenty-six years chiefly because it was found that they increased with altitude at a rapid rate," Dr. Tesla said he had discovered "the astonishing fact that the effects at high altitudes are of an entirely different nature, having no relation whatever to cosmic rays."

He gave a detailed technical description of his conclusions from research and calculations concerning the cosmic ray, and continued:

"For the time being, I must content myself with the announcement of the salient facts, but in due course I expect to be able to give more or less accurate technical data relating to all particulars of this discovery."

Digressing from his prepared statement, he said: "I am proud of these discoveries, because many have denied that I am the original discoverer of the cosmic ray. I was fifteen years ahead of other fellows who were asleep. Now no one can take away from me the credit of being the first discoverer of the cosmic ray on earth."

Dr. Tesla's audience stirred as he took up the next phase of his discoveries.

"I have devoted much of my time during the year past," he said, "to the perfecting of a new small and compact apparatus by which energy in considerable amounts can now be flashed through interstellar space to any distance without the slightest dispersion."

To Claim French Award

Explaining that he did not refer to his "universal peace discovery" Dr. Tesla continued.

"I am expecting to put before the Institute of France an accurate description of the devices with data and calculations and claim the Pierre Guzman prize of 100,000 francs for means of communication with other worlds, feeling perfectly sure that it will be awarded to me. The money, of course, is a trifling consideration, but for the great historical honor of being the first to achieve this miracle I would be almost willing to give my life.

"I am just as sure that prize will be awarded to me as if I already had it in my pocket. They have got to do it. It means it will be possible to convey several thousand units of horsepower to other planets, regardless of the distance. This discovery of mine will be remembered when everything else I have done is covered with dust."

Reporters questioned Dr. Tesla closely on his report of an interplanetary communication system. He said he had been working in several laboratories, but refused to disclose where they were. Asked if he had a working model of the apparatus, he said "it employs more than three dozen of my inventions, it is a complex apparatus, an agglomeration of parts."

"It is absolutely developed," he declared. "I wouldn't be any surer that I can transmit energy 100 miles than I am of the fact that I can transmit energy 1,000,000 miles up."

A different kind of energy than is commonly employed must be used, however, he said, explaining further that "you must realize it travels through a channel of less than one-half of one-millionth of a centimeter."

"I could undertake a contract to manufacture the apparatus," he asserted.

Dr. Tesla declared that "life on other planets is an infinite probability, a certitude." A difficulty in using his apparatus, he said, would lie in hitting other moving planets with "the needlepoint of tremendous energy," but astronomers could help solve this problem.

The point of energy could be aimed at the moon and "we very easily could see the effects, see the splash and the volatilization of matter." He also pictured the possibility of advanced thinkers living on other planets and also experimenting in this field, but mistaking the Tesla energy rays for some form of cosmic rays.

Dr. Tesla provoked a new stir with his next announcement:

"My most important invention from a practical point of view," he said, "is a new form of tube with apparatus for its operation."

Reports Tube of New Type

Recalling experiments with other tubes, he said he had been "rewarded with complete success and had "produced a tube which it will be hard to improve further."

"It is of ideal simplicity," he said, "not subject to wear and can be operated at any potential, however high - even 100,000,000 volts - that can be produced. It will carry heavy currents, transform any amount of energy within practical limits and it permits easy control and regulation of the same.

"I expect that this invention, when it becomes known, will be universally adopted in preference to other form of tubes and that it will be the means of obtaining results undreamed of before.

"Among others, it will enable the production of cheap radium substitutes in any desired quantity and will be, in general, immediately more effective in the smashing of atoms and the transmutation of matter. However, this tube will not open up a way to utilize atomic or subatomic energy for power purposes."

"It will cheapen radium so," Dr. Tesla added, "that it will be just a cheap - well, it will get down to \$1 a pound, in any quantity."

Expressing "annoyance" that some newspapers had indicated he would "give a full description" of his atom-smashing tube at yesterday's luncheon, Dr. Tesla said he was bound by financial obligations "involving vast sums of money" against releasing this information.

"But it is not an experiment," he declared. "I have built, demonstrated and used it. Only a little time will pass before I can give it to the world."

A final discovery announced by Dr. Tesla involved a new method and apparatus for further perfection of vacuum tubes.

"What may be accomplished by means of such vacua is a matter of conjecture, but it is obvious that they will make possible the production of much more intense effects in electron tubes," he said.

Before and during the luncheon, Dr. Tesla entertained his guests with colorful personal reminiscences and observations including his opinions on dieting and immortality.

New York Herald Tribune
July 27, 1937

DR. TESLA'S HONORS

To the New York Herald Tribune:

I have been a reader of your excellent paper for more than fifty years and feel much obliged to you for the pleasure and enlightenment derived from its perusal. Many of your admirable editorials are on my files. Under these circumstances it is unfortunate that your issue of Sunday, July 11, contained a report very injurious to me.

The particularly damaging statement is: "The decorations made very little impression on Dr. Tesla. 'They mean nothing - take them away,' said Dr. Tesla."

I should say that the expression on my face in the photograph accompanying the report, would be sufficient to disprove the above assertion. When it became necessary to clear the table I was very anxious that the precious objects be placed in safe hands and requested my old friend, George Scherff, auditor of the Union Sulphur Company, who was one of the honored guests, to take care of them. Moreover, as soon as I was free, I cabled His Royal Highness Prince Regent Paul of Yugoslavia and to His Excellency Dr. Eduard Benes, President of Czechoslovakia, expressing my profound gratitude for the rare distinctions conferred upon me and my great pride of possessing them. It was desirable to show in the photograph the Yugoslav Minister handing me the order of the White Eagle but His Excellency Konstantin Fotitch, besides being a master in diplomacy, is a man of commanding stature in other respects, and he did not insist. However, a more charming dignitary than Dr. Vladimir Hurban, Minister of Czechoslovakia, could not be imagined.

NIKOLA TESLA

New York, July 24, 1937

Nikola Tesla, electrical scientist, Felix Frankfurter, of the Harvard Law School, and Giovanni Martinelli, Metropolitan Opera tenor, were recipients of awards from the National Institute of Immigrant Welfare at the Hotel Biltmore, New York City, on May 11, 1938. Due to an illness, the following letter from Nikola Tesla was read at the presentation. A report of the presentation is given in The New York Times, May 12, 1938, p. 26, col. 1.

Mr. Chairman,
Members of the Institute of Immigrant Welfare,
Ladies and Gentlemen:

I can not find words to express adequately my keen regret for being unable to receive, in person, the high distinction which the Institute of Immigrant Welfare has conferred upon me. Although my recovery from injuries sustained in an automobile accident six months ago is almost complete, I do not feel equal to the task of appearing in public and meeting the obligations which this would impose upon me.

My coming to this country was a great adventure - every detail of which is still vivid in my memory. Early in 1884, while employed by a French Company in Paris, I made important improvements in dynamos and motors and was engaged by the Edison interests in New York to design and construct similar machines for them. It had been the height of my ambition and my most ardent wish to come in contact with Edison and see America. Accordingly, I undertook the voyage and after losing my money and tickets and passing through a series of mishaps, including a mutiny in which I nearly lost my life, I landed on these blessed shores with four cents in my pocket. My first intention was to look up a close American friend before going to the Edison establishment. On my way uptown I came to a small machine shop in which the foreman was trying to repair an electric machine of European make. He had just given up the task as hopeless and I undertook to put it in order without a thought of compensation. It was not easy but I finally had it in perfect running condition. I was astonished when he gave me twenty dollars and wished that I had come to America years before. The next day I was thrilled to the marrow by meeting Edison who began my American education right then and there. I wanted to have my shoes shined, something I considered below my dignity. Edison said: "Tesla, you will shine the shoes yourself and like it. He impressed me tremendously. I shined my shoes and liked it.

I began the work for which I was engaged immediately and after nine months of strenuous effort I fulfilled my contract rigorously. The manager had promised me fifty thousand dollars but when I demanded payment, he merely laughed. "You are still a Parisian," remarked Edison, "when you become a full-fledged American you will appreciate an American joke." I felt deeply hurt as I had expected to use the money in the development of my alternating system and when some people proposed to form a company under my name, I accepted eagerly. Here was the opportunity I had vainly sought for years but my new friends were adamant in their resolve not to have anything to do with the worthless alternating currents which Edison condemned as deadly. They desired an arclight system and I had to comply with their request though the delay of my cherished plans was agonizing. In one year of day and night application, I managed to perfect the system which was adopted for lighting the city and some factories in the neighborhood. Then came the hardest blow I ever received. Through some local influences, I was forced out of the company losing not only all my interest but also my reputation as engineer and inventor. After that I lived through a year of terrible heartaches and bitter tears, my suffering being intensified by material want. Very often I was compelled to work as a laborer and my high education in various branches of science, mechanics and literature seemed to me like a mockery. Finally, I had the good fortune of meeting two capable and honest men who listened to me and came to my assistance. They organized a company, provided a laboratory and gave me a modest but sure financial support. I perfected my motors quickly having nothing else to do except to carry out plans I had formed years

before. My inventions proved a success and attracted the attention of George Westinghouse. He was, in my opinion, the only man on this globe who could take my alternating system under the circumstances then existing and win the battle against prejudice and money power. He was a pioneer of imposing stature, one of the world's true noblemen of whom America may well be proud and to whom humanity owes an immense debt of gratitude.

I have to add that in all my troubles I did not neglect to declare my intention of becoming a citizen of this glorious country and in due course I secured my papers making me a proud and happy man.

Nikola Tesla

Science News Letter
Oct. 8, 1938, p. 238.

Reference to Compass in 13th Century Poem.

By Nikola Tesla

Among the oldest references to the mariner's compass is a passage in a poem by a little known French writer, Guyot de Provins, who wrote early in the thirteenth century, I first came upon this reference many years ago, during a period of omnivorous reading while I was convalescing from a nearly fatal attack of cholera morbus.

Among the many books I received there was a large volume of citations, gems of literature of all nations in a dozen languages, which aroused my special interest. Most of the excerpts from famous works, in verse or prose, collected by the author, impressed me so strongly by their beauty of thought and expression that even now I can recite many of them without a miss.

It was in this volume that I found the reference to the compass mentioned in the introduction. It was credited to Guyot de Provins, a French poet of the twelfth and thirteenth centuries, and, if my memory serves me well, worded as follows:

"Quand la mer est obscure et brune
Qu'on ne voit ni étoile ni lune
Donc font l'aiguille allumer,
Puis n'ont garde de s'égarer
Contre l'étoile va la pointe."

I translate freely:

"When gloomy darkness hides the sea
And one no star and moon can see
They turn on the needle the light,
Then from the straying they have no fright
For the needle points to the star."

As a rule, medieval records do not commend themselves for clarity; in fact, not a few are of very small value to the searcher. It is therefore remarkable that this ancient reference to the compass should be so strikingly clear and explicit.

After reading Guyot's verses one is impelled by the wish to know something more about him. With this intention I tried to obtain information from the New York Public Library but his name was not mentioned in any of the catalogues. I then made a thorough examination of the General Index, which was equally unsuccessful, but found a brief notice in the Grande Encyclopédie Française.

This item being of unusual interest I have an English translation:

Guyot de Provins, French poet, towards 1200. Undoubtedly, after being a minstrel and going perhaps to Jerusalem, he became a Benedictine in Clairvaux and later in Cluny. He composed between 1203 and 1208, in a style lively and original, but harsh and hard, a satirical work consisting of 2691 octosyllabic verses, which he entitled "Bible," probably to indicate that he intended to say only what is true, and in which he passed in review almost the whole contemporary society. Especially noteworthy is his criticism of the Pope, expressed with great independence, and that of the high clergy and physicians, and a number of passages in which he argues that the compass was known in his time.

Reprinted with permission from SCIENCE NEWS, the weekly news magazine of science, copyright 1938 by Science Service, Inc.

New York Herald
July 26, 1939

THE SOVIET SACRIFICE FOR SPAIN

An Estimate That Republic Received Billion and a Half Dollars

To the New York Herald Tribune:

Your issue of July 9, 1939, contains an article relating to the seizure of Spanish gold by the Soviet government. Another one, dealing with the same subject, appeared in "The Saturday Evening Post" of April 15, 1939. Without entering into a discussion of the merits of these comments upon the question raised, I may remark that, for obvious reasons, any expression of opinion concerning this matter by Americans is likely to be very unfavorable to the Soviet government, and in the interest of common justice it should be weighed without prejudice. What I wish to bring to the attention of fair-minded readers is that the articles referred to do not give the slightest hint in regard to the chief fact to be ascertained, which had a profound bearing on the course decided upon by the Soviets - namely, the sacrifice their struggle on behalf of the oppressed party in Spain involved. They fought vigorously for a cause considered rightful by a large portion of the population, and the ownership of gold and other property was undecided until the termination of the conflict.

Everybody knows that modern warfare is desperately expensive, but few will realize how costly it must have been for the Soviet government, under the disadvantages, obstacles and handicaps confronting it. I was desirous of making an approximate estimate of the cost, and with this object in view I gathered all the available data. Considering carefully the actual outlays in money, the loss of men, of airplanes, guns and other implements of war, ships and munitions, and the supply of food, oil and all kinds of provisions transported from great distance, etc., I have satisfied myself that the Soviet government must have spent, at the very least \$1,500,000,000. If this estimate is reasonably accurate, the Spanish gold appropriated amounted to about one-third of the cost. Any government would have acted so under similar circumstances. England, France, Germany and Italy are on record with deeds not at all commendable. What the Soviet government did was perfectly legitimate, in view of the preceding events.

The idea that the boxes brought from Spain were sufficient to cover Red Square is absurd. It would mean not five but something like one hundred times that amount of gold. The metal always is shipped in ounces and its value determined from the prevailing market quotations.

Through the attitude of England and France the Soviet government found itself isolated, and Stalin then made a proposal for non-interference. But Italy and

Germany paid no attention to it and poured tens of thousands of men into Spain to Franco's assistance. Even then Russia was ready to carry on the war. She could swallow Italy in a gulp and not suffer dyspepsia, and if Hitler dared to attack her he would have been badly defeated and Germany would have become again an empire under the Hohenzollern dynasty, probably with the restoration of the status quo ante Hitler regime and recreated free Czechoslovakia. England and France being emphatically against Russian influence in Spain, Stalin had to withdraw, but in so doing he certainly did not "knife" the Spanish republic.

NIKOLA TESLA

New York, July 23, 1939

HOTEL NEW YORKER

1939

A STORY OF YOUTH TOLD BY AGE

DEDICATED TO

MISS POLA FOTITCH

BY ITS AUTHOR

NIKOLA TESLA

My dear Miss Fotitch:

I am forwarding to you the "Calendar of Yugoslavia" of 1939 showing the house and community in which I had many joyful and sad experiences and odd adventures and in which also, by a coincidence bizarre, I was born. As you may see from the photograph on the sheet for June, the old-fashioned building is located at the foot of a wooded hill called Bogdanić. Adjoining it is a church and behind it a little further up a graveyard. Our nearest neighbors were two miles away and in the winter, when the snow was six or seven feet deep, our isolation was complete.

My mother was indefatigable and worked regularly from four o'clock in the morning till eleven in the evening. From four to breakfast time, 6 A.M., while others slumbered, I never closed my eyes but watched my mother with intense pleasure as she attended quickly - sometimes running - to her many self-imposed duties. She directed the servants to take care of all domestic animals, milked the cows, performed all sorts of labor unassisted, set the table, prepared breakfast for the whole household and only when it was ready to be served did the rest of the family get up. After breakfast everybody followed by mother's inspiring example. All did their work diligently, liked it and so achieved a measure of contentment. But I was the happiest of them, the fountain of my enjoyment being our magnificent Maćak - the finest of all cats in the world. I wish that I could give you an adequate idea of the depth of affection which existed between me and him. You would look vainly in the mythological and historical records for such a case. We simply lived one for the other. Wherever I went Maćak followed primarily owing to our mutual love and then again moved by the desire to protect me. When such a necessity presented itself he would rise to twice his normal height, buckle his back and with the tail as rigid as a metal bar and whiskers like steel wires he would give vent to his rage by explosive puffs Pfftt! Pfftt! It was a terrifying sight and whatever provoked him, human being or animal, beat a hasty retreat.

In the evening we went through our usual program. I would run from the house

along the church and he would rush after me and grab me by the trousers. He tried hard to make me believe that he would bite, but the instant his needle sharp incisors penetrated the clothing the pressure ceased and their contact with my skin was as gentle and tender as that of a butterfly alighting on a petal. He liked best to roll on the grass with me. While we were doing this he bit and clawed and purred in rapturous pleasure. He fascinated me so completely that I too bit and clawed and purred. We just could not stop and rolled and rolled and rolled and rolled in a delirium of delight. We indulged in this enchanting sport day by day except on rainy weather. In respect to water Mačak was very fastidious. He would jump six feet to avoid wetting his paws. On such occasions we went into the house and, selecting a nice cosy place, abandoned ourselves for each other in affectionate embracement. Mačak was scrupulously clean, had no fleas or bugs whatever, shed no hair and showed none of the objectionable traits and habits of cats as I knew them later. He was touchingly delicate in signifying his wish to be let out at night and scratched the door gently for readmittance.

Now I must tell you of a strange and unforgettable experience which bore fruit in my later life. Our home is about eighteen hundred feet above sea level and in the winter we had dry weather as a rule, but sometimes it happened that a warm wind from the Adriatic would blow persistently for a long time, melting rapidly the snow, flooding the land and causing great loss of property and life. We would then witness the terrifying spectacle of a mighty seething river carrying wreckage and tearing down everything moveable in its way. Since I often visualize the events of my youth to find relief from great and dangerous mental strain and when I think of the scene the roar of the waters fills my ears and I see as vividly as then, their tumultuous flow and the mad dance of the wreckage. This leaves me, for a while, sad and depressed. But always agreeable are my recollections of winter with its dry cold and snow of immaculate white.

It happened that on the day of my experience we had a cold drier than ever observed before. People walking in the snow left a luminous trail behind them and a snowball thrown against an obstacle gave a flare of light like a loaf of sugar hit with a knife. It was dusk of the evening and I felt impelled to stroke Mačak's back. Mačak's back was a sheet of light and my hand produced a shower of sparks loud enough to be heard all over the place. My father was a very learned man, he had an answer for every question. But this phenomenon was new even to him. Well, he finally remarked, this is nothing but electricity, the same thing you see on the trees in a storm. My mother seemed alarmed. Stop playing with the cat, she said, he might start a fire. I was thinking abstractedly. Is nature a gigantic cat? If so, who strokes its back? It can only be God, I concluded. You may know that Pascal was an extraordinarily precocious child who attracted attention before he reached the age of six years. But here I was, only three years old, and already philosophising!

I can not exaggerate the effect of this marvellous sight on my childish imagination. Day after day I asked myself what is electricity and found no answer. Eighty years have gone by since and I still ask the same question, unable to answer it. Some pseudo scientist of whom there are only too many may tell you that he can, but do not believe him. If any of them knew what it is I would also know and the chances are better than any of them for my laboratory and practical experiences are more extensive and my life covers three generations of scientific research.

My childhood in Mačak's delightful company and undying friendship would have passed blissfully if I did not have a powerful enemy, relentless and irreconcilable. This was our gander, a monstrous ugly brute, with a neck of an ostrich, mouth of a crocodile and a pair of cunning eyes radiating intelligence and understanding like the human. I aroused his ire by throwing pebbles at him, a most foolish and reckless act which I bitterly regretted afterwards. I liked to feed our pigeons,

chickens, and other fowl, take one or the other under my arm and hug and pet it. But the brute would not let me. The moment I entered the poultry yard he would attack me and as I fled grab me by the seat of my trousers and shake me viciously. When I finally managed to free myself and run away he would flap his huge wings in glee and raise an unholy chatter in which all the geese joined. When I grew up two aunts of mine used to tell me how I answered certain questions they asked. One was Aunt Veva who had two protruding teeth like the tusks of an elephant. She loved me passionately and buried them deep in my cheek in kissing me. I cried out from pain but she thought it was from pleasure and dug them in still deeper. Nevertheless I preferred her to the other aunt whose name has slipped from my memory and she used to glue her lips to mine and suck and suck until by frantic efforts I managed to free myself gasping for breath. These two aunts amused themselves by asking me all sorts of questions of which I remember a few. Are you afraid of Luka Bogić? No! Luka always carried a gun and threatened to shoot. He robbed other boys of pennies and gave them to me. Are you afraid of the cow? No! That was one of our cows and very nice until one day I slid from a fence on her back for a ride when she made off with me bellowing and threw me. I was none the worse for the experience. Are you afraid of the bad wolf? No! No! This was the wolf I met in the woods near the church. He was looking at me fixedly and approaching slowly. I shouted as usual when a wolf is around and he trotted away slowly. My present visualization of this scene is astonishingly sharp and clear. After a number of such questions one of the aunts asked me; Are you afraid of the gander? Yes! Yes! I replied emphatically, I am afraid of the gander! I had good reason to be. One summer day my mother had given me a rather cold bath and put me out for a sun warming in Adam's attire. When she stepped in the house the gander espied me and charged. The brute knew where it would hurt most and seized me by the nape almost pulling out the remnant of my umbilical cord. My mother, who came in time to prevent further injury, said to me: "You must know that you can not make peace with a gander or a cock whom you have taunted. They will fight you as long as they live." But now and then I would play in the poultry yard to my heart's content for on certain days our geese, led by the gander, rose high in the air and flew down to the meadow and brook where they sported like swans in the water and probably found some food. I would then feed and pet the pigeons, the poultry and our grand resplendant cock who liked me. In the evening the gander brought back his flock who made a few turns above the house and then came down with a deafening noise. The sight of the flying geese was a joy and inspiration to see.

MECHANICAL THERAPY

by

NIKOLA TESLA

(No Date)

In order to convey a clear idea of the significance and revolutionary character of this discovery it is indispensable to make a brief statement regarding ELECTRICAL THERAPY.

Fifty years ago, while investigating high frequency currents developed by me at that time, I observed that they produced certain physiological effects offering new and great possibilities in medical treatment. My first announcement spread like fire and experiments were undertaken by a host of experts here and in other countries. When a famous French physician, Dr. D'Arsonval, declared that he had made the same discovery, a heated controversy relative to priority was started. The French, eager to honor their countryman, made him a member of the Academy, ignoring entirely my earlier publication. Resolved to take steps for vindicating my claim, I went to Paris, where I met Dr. D'Arsonval. His personal charm disarmed me completely and I abandoned my intention, content to rest on the record. It shows that my disclosure antedated his and also that he used my apparatus in his demonstrations. The final judgment is left to posterity.

Since the beginning, the growth of the new art and industry has been phenomenal, some manufacturers turning out daily hundreds of sets. Many millions are now in use throughout the world. The currents furnished by them have proved an ideal tonic for the human nerve system. They promote heart action and digestion, induce healthful sleep, rid the skin of destructive exudations and cure colds and fever by the warmth they create. They vivify atrophied or paralyzed parts of the body, allay all kinds of suffering and save annually thousands of lives. Leaders in the profession have assured me that I have done more for humanity by this medical treatment than by all my other discoveries and inventions. Be that as it may, I feel certain that the MECHANICAL THERAPY, which I am about to give to the world, will be of incomparably greater benefit. Its discovery was made accidentally under the following circumstances.

I had installed at the laboratory, 35 South Fifth Avenue, one of my mechanical oscillators with the object of using it in the exact determination of various physical constants. The machine was bolted in vertical position to a platform supported on elastic cushions and, when operated by compressed air, performed minute oscillations absolutely isochronous, that is to say, consuming rigorously equal intervals of time. So perfect was its functioning in this respect that clocks driven by it indicated the hour with astronomical precision. One day, as I was making some observations, I stepped on the platform and the vibrations imparted to it by the machine were transmitted to my body. The sensation experienced was as strange as agreeable, and I asked my assistants to try. They did so and were mystified and pleased like myself. But a few minutes later some of us, who had stayed longer on the platform, felt an unspeakable and pressing necessity which had to be promptly satisfied, and then a stupendous truth dawned upon me. Evidently, these isochronous rapid oscillations stimulated powerfully the peristaltic movements which propel the food-stuffs through the alimentary channels. A means was thus provided whereby their contents can be perfectly regulated and controlled at will, and without the use of drugs, specific remedies or internal applications whatever.

When I began to practice with my assistants MECHANICAL THERAPY we used to finish our meals quickly and rush back to the laboratory. We suffered from dyspepsia and various stomach troubles, biliousness, constipation, flatulence and other disturbances, all natural results of such irregular habit. But after only a week of

application, during which I improved the technique and my assistants learned how to take the treatment to their best advantage, all those forms of sickness disappeared as by enchantment and for nearly four years, while the machine was in use, we were all in excellent health. I cured a number of people, among them my great friend Mark Twain whose books saved my life. He came to the laboratory in the worst shape suffering from a variety of distressing and dangerous ailments but in less than two months he regained his old vigor and ability of enjoying life to the fullest extent. Shortly after, a great calamity befell me: my laboratory was destroyed by fire. Nothing was insured and the loss of priceless apparatus and records gave me a terrific shock from which I did not recover for several years. The enforced discontinuance of MECHANICAL THERAPY also caused me deep regret. I had evolved a wonderful remedy for ills of inestimable value to mankind and invented apparatus offering unbounded commercial possibilities but when I came to consider practical introduction I realized that it was entirely unsuitable. It was big, heavy and noisy, called for a continuous supply of oil, part of which was discharged in the room as fine spray; it consumed considerable power and required a number of objectionable accessories. During the succeeding years I made great improvements and finally evolved a design which leaves nothing to be desired. The machine will be very small and light, operate noiselessly without any lubricant, consume a trifling amount of energy and will be, to my knowledge, the most beautiful device ever put on the market. The intention is to exhibit it in action at the occasion of my annual reception in honor of the Press which has been, unfortunately, delayed this year, and I anticipate that it will elicit great interest and receive wide publicity. Unless I am grossly mistaken it will be introduced very extensively and, eventually, there will be one in every household.

The practical application of MECHANICAL THERAPY through my oscillators will profoundly affect human life. By insuring perfect regularity of evacuations the body will function better in every respect and life will become ever so much safer and more enjoyable. One of the most important results will be the great reduction - amounting possibly to seventy-five per cent - in the number of heart failures, which are mostly caused by some acute upset of the digestive process and normal operation of the stomach. Another vital improvement will be derived from the quickened removal of toxic excretions of organs affected by disease. It is reasonable to expect that through this and other healthful actions ulcers and similar internal lesions or abscesses will be cured and relief might be obtained even in case of a cancer or other malignant growth. Skilled physicians and surgeons will be able to perform veritable miracles with such oscillations. They stimulate strongly the liver, spleen, kidneys, bladder and other organs and by these desirable actions they must contribute not a little to well being. Persons suffering from anemia of any form will be especially helped by the treatment. But the greatest benefit will be derived from it by women who will be able to reduce without the usual tantalizing abstinence, privation, sacrifice of time and money and torture they have to endure. They will improve much in appearance, acquire clear eyes and complexions and it may be safely predicted that long continued treatment will bring forth feminine beauty never seen before. It is not to be forgotten that the elimination of countless drugs, patent medicines and specific remedies of all kinds taken internally, by which millions of people doom themselves to an early grave, will be of untold good to humanity.

Courtesy of Nikola Tesla Papers, Rare Book and Manuscript Library,
Columbia University.

THE NEW TESLA ELECTRIC HEATER - by Nikola Tesla

(No Date)

STRICTLY CONFIDENTIAL

This device is greatly superior to the usual flat core type in efficiency and other respects. It consists of a thin polished metal tube acting as reflector and a base equipped with switch and connecting terminals and carrying spaced resistor wires concentric with the tube and at a certain distance from the inner surface of the same. In this arrangement the diffuse radiation is virtually eliminated, and the heater operates as if the resistor were not present, the rays being projected from the reflector radially to the central or focal region occupied by the boiling pot.

The principal advantages thus secured are the following:

1. A very high efficiency, as much as 96% being attainable.
2. The efficiency is practically the same whether the pot is large or small since the density of the rays is inversely as the diameter of the vessel.
3. Due to these features the current consumption is hardly more than half of that in the best heaters of the type referred to.
4. The resistor has a relatively much longer life and can be made to last almost indefinitely in some cases. Also less wire can be used if desired.
5. The heat being largely confined to the range, the kitchen remains comparatively cool.
6. Another practical advantage is greater safety from a variety of accidents frequently occurring with ordinary ranges.
7. The new heater is especially adapted for use on shipboard, Pullman cars, aerial vehicles and automobiles.
8. Likewise, it is suitable for all kinds of service on the table, being free from the objections of the present type.
9. It saves considerable time in certain applications.
10. Owing to simplicity, the cost of manufacturing is low.

This material courtesy of Nikola Tesla Papers,
Rare Book and Manuscript Library, Columbia University.

TESLA'S NEW SYSTEM OF FLUID PROPULSION - by Nikola Tesla

(No Date)

In subduing the forces of Nature to his service man must invariably avail himself of some process in which a fluid acts as carrier of energy, this being an essential step in any industrial undertaking dependent on mechanical power. Evidently then, a discovery or radical departure in that domain must be of extreme importance and far-reaching influence on the existing conditions and phases of modern life.

Fluid propulsion is now effected by means of pistons, vanes or blades, which entail complexity of construction and impose many limitations on the propelling as well as propelled mechanism and its performance. Tesla has dispensed with these devices and produced machines of extraordinary simplicity which, moreover, are in many other respects superior to the old types universally employed. A few words will be sufficient to convey a clear idea of his invention.

Every fluid, as water or air, possesses two salient properties: adhesion and viscosity. Owing to the first it is attracted and clings to a metallic surface; by virtue of the second it resists the separation of its own particles. As an inevitable consequence a certain amount of fluid is dragged along by a body propelled through it; conversely, if a body be placed in a fluid in motion it is impelled in the direction of movement. The practical forms of Tesla's apparatus consist of flat, circular disks, with central openings, mounted on a shaft and enclosed in a casing provided with ports at the peripheral and central portions, when deriving energy from any kind of fluid it is admitted at the periphery and escapes at the centre; when, on the contrary, the fluid is to be energized, it enters in the centre and is expelled at the periphery. In either case it traverses the interstices between the disks in a spiral path, power being derived from, or imparted to it, by purely molecular action. In this novel manner the heat energy of steam or explosive mixtures can be transformed with high economy into mechanical effort; motion transmitted from one shaft to another without solid connection; vessels may be propelled with great speed; water raised or air compressed; an almost perfect vacuum can be attained, substances frozen and gases liquefied.

While this improvement has the broadness and applicability of a fundamental mechanical concept, the widest field for its commercial exploitation is, obviously, the thermodynamic conversion of energy.

The commercial value of a prime mover is determined by its efficiency, specific performance relative to weight and space occupied, cheapness of manufacture, safety and reliability of operation, adaptability to construction in large units, capability of running at high peripheral velocity, reversibility, and a number of other features of lesser importance. In the majority of these a machine, operating on the new principle, excels. But there is one quality which is most desirable in a thermo-dynamic transformer from the economic point of view, and that is great resistance to deterioration and impairment of efficiency by heat.

The employment of high temperature is of such vital bearing on the efficiency of prime movers that it is of paramount importance to extend the thermal range as far as practicable. In the present state of the art radical progress towards more economical transformation of the energy of fuel can only be achieved in that direction. Such being the case, the capability of the machine to withstand deteriorating effects of great heat is the controlling factor in determining its commercial value. In that most desired quality the Tesla turbine surpasses all the older types of heat motors. The Diesel and other internal combustion engines are fatally limited in this respect by their complete dependence on closely fitting sliding joints and un-failing supply of clean lubricant; while in the present forms of turbine buckets, blades and inherent mechanical deficiencies impose similar restrictions. These

parts are too delicate and perishable to serve as elements of a gas turbine and this has been the main obstacle in the way of its successful realization. The rotor of the Tesla turbine presents a relatively enormous active area and the wear is quite insignificant as the fluid, instead of striking against the propelling organs in the usual destructive manner, flows parallel with the same, imparting its momentum by adhesion and viscosity instead of impact. Moreover, it has been shown that the efficiency of this form of rotor is not impaired to any appreciable degree by a roughening of the disks and that it operates satisfactorily even if the working medium is corrosive to an extent.

The universal adoption of steam as motive power under certain standard conditions, settled upon in the course of time, gradually forced upon the minds of engineers the Rankine Cycle Efficiency as criterion of performance and long continued endeavors to improve the same have finally resulted in complex multistage constructions entirely unsuitable for high temperatures. The Tesla turbine, by virtue of its exceptional heat-resisting and other unique properties, makes possible the attainment of great fuel economy with but a single stage, incidentally offering the additional advantages of an extremely simple, small, compact, and reliable mechanism. But perhaps the chief commercial value of this new prime mover will be found in the fact that it can be operated with the cheapest grade of crude oil, colloidal fuel, or powdered coal, containing considerable quantities of grit, sulphur and other impurities, thus enabling vast sums of money to be saved annually in the production of power from fuel.

The Tesla turbine also lends itself to use in conjunction with other types, especially with the Parsons with which it forms an ideal combination. Although its practical introduction has been delayed by the force of circumstances, a number of years have been spent in exhaustive investigations and experiments on the basis of which the performance in any given case can be closely calculated. The first public tests were made before the outbreak of the war at the Waterside Station of the New York Edison Company where several machines, ranging from 100 to 5000 h.p., were installed and operated with satisfactory results. That the invention was appreciated by the technical profession may be seen from the excerpts of statements by experts and periodicals printed on the annexed page.

The salient advantages of the Tesla turbine may be summed up as follows:

EFFICIENCY: The most economical of the present prime movers is the Diesel engine. But, quite apart of many practical and commercial drawbacks, inseparable from this type, it is entirely dependent on comparatively expensive oil, so that the Tesla Gas Turbine, working with much cheaper fuel, would have the better in competition even if its efficiency as a thermodynamic transformer were appreciably lower, all the more so in view of its greater mechanical perfection.

Referring to turbines, all of which are surpassed by the Parsons in economy as well as extent of use, definite limits have already been reached and the only possibilities of saving fuel exist in the employment of steam at very high superheat and utilization of gas or oil as motive fuel. But none of the prime movers mentioned is adapted for such operation and although every effort has been made in this direction, no signal success has been achieved. The superheat is at most 250° F, this being considered the maximum permissible. All attempts to considerably extend the thermal range have failed chiefly because of the inability of bucket structures to withstand the action of intense heat. The Tesla Turbine can operate quite satisfactorily with the motive agent at very high temperature and, owing to this quality, lends itself exceedingly well to these purposes.

SPECIFIC PERFORMANCE: In this particular it is superior to all other forms. Each disk is virtually the equivalent of a whole bucket wheel, and as many of them take up but a small width the output of the machine, considering its weight and size, is surprisingly great. This, while not being a measure of efficiency, is nevertheless

a feature of considerable importance in many instances.

CHEAPNESS OF MANUFACTURE: The new turbine can be produced without a single machined part except the shaft, all the disks being punched and the casing pressed. By this method, with proper machinery installed on a large scale, the cost of production may be reduced to a figure never deemed possible in the construction of an engine. What is more, this can be done without material sacrifice of efficiency as small clearances are not essentially required.

SAFETY AND RELIABILITY OF OPERATION: There is an ever present danger in the running of high speed machines. A bucket turbine may at any moment run away and wreck the plant. Such accidents have happened again and again and this peril has often proved to be a deterrent to investment. A remarkable quality of this turbine is its complete safety. As regards the wear and tear of the propelling organs it is significant and, in any event, of no consequence on the performance.

ADAPTABILITY TO CONSTRUCTION IN LARGE UNITS: In all the present machines there is a distinct limit to capacity, for although large units can be manufactured, they are very costly and difficult to manage. The new turbine is so simple and the output so large that the limits in this direction can be greatly extended.

RESISTANCE TO DETERIORATION BY HEAT AND OTHER AGENTS: In this feature it has an overwhelming advantage over the old type in which the maintenance of smooth surfaces and sharp edges is indispensable to efficient working. In the Tesla turbine, for the reasons already stated, the destructive actions of heat and corrosive agents are much less pronounced and of relatively negligible effect. This fact has a most important bearing on the saving of fuel.

CAPABILITY OF RUNNING AT HIGH PERIPHERAL SPEED: In this respect also it is superior to others. The rotating structure carries no load and is excellently adapted to withstand tensile stresses. Judging from the most recent turbine practice this quality should be of special value.

REVERSIBILITY: The present turbines are greatly handicapped by their incapability of reversal which is a very serious defect in certain applications, as the propulsion of vessels, necessitating the employment of auxiliary turbines which detracts from the propulsive power and adds materially to the cost of production and maintenance of the equipment. The Tesla turbine has the unique property of being reversible; not only this but it operates with the same efficiency in either direction. For marine purposes it therefore constitutes an ideal motor whether used alone or in conjunction with older types.

Besides the above it possesses other desirable features, constructive and operative, which will add to its value and adaptability to many industrial and commercial uses as, railroading, marine navigation, aerial propulsion, generation of electricity, refrigeration, operation of trucks and automobiles, hydraulic gearing, agriculture, irrigation, mining and similar purposes.

EXPRESSIONS OF OPINION ON THE TESLA TURBINE

C. B. Richards, Professor Emeritus of Mechanics, Yale University:

"I am amazed at the development of power given by the turbine and stunned by the exhibit."

F. Sargent, Chief Engineer and Turbine Expert:

"I am impressed with the newness and novelty of the underlying principle of this invention. It is such as will claim the attention and admiration of anyone of a scientific turn of mind in a mechanical direction."

Reynold Janney, Chief Engineer, Universal Transmisssion Co.:

"It is a great invention."

Brigadier Allen of the War Department:

"Something new in the world. Officers are greatly impressed with it."

Miller Reese Hutchinson, Chief Engineer:

"It is the greatest invention of the age."

Arnold Trinyi, Chief Engineer, Oelfeurungs-Gesellschaft, Germany:

"The ideal of the turbine engine."

B. R. T. Colline (Power Plant Economist):

"It is a wonderful turbine."

The Motor World:

"The new principle unquestionably is a great contribution to science and engineering, great in its simplicity and breadth of application."

Scientific American:

"Considered from the mechanical standpoint, the turbine is astonishingly simple and economical in construction, should prove to possess such a durability and freedom from wear and breakdown as to place it, in these respects, far in advance of any type of steam or gas motor of the present day."

Engineering Magazine:

"An entirely new form of prime mover with interesting possibilities."

Technical World Magazine:

"The Tesla Turbine is the apotheosis of simplicity. It is so violently opposed to all precedent that it seems unbelievable."

From Numerous Articles and Comments:

"The turbine is different in principle to any heretofore in use and one which will take less room and less coal than the best engine now running" . . . "Turbine of revolutionary design" . . . "Improvement in dynamics which promises revolutionary results" . . . "Results seem revolutionary to the point of staggering the imagination" . . . "This motor will revolutionize the turbine industry" . . . "Wonderful motor. Extraordinary mechanical principle" . . . etc., etc.

This material courtesy of Nikola Tesla Papers, Rare Book and Manuscript Library, Columbia University.

BOOKS AVAILABLE FROM TESLA BOOK COMPANY

- Dr. Nikola Tesla Bibliography-by John T. Ratzlaff and Leland I. Anderson. Contains approx. 3,000 references, partially annotated. 8½ x 11, perfect bound, soft cover, 230 pp.
- Dr. Nikola Tesla, I English/Serbo-Croatian Diary Comparison, II Serbo-Croatian Diary Commentary, III Tesla/Scherff Colorado Springs correspondence-by John T. Ratzlaff and Fred A. Jost. Contains important supplementary information to Nikola Tesla, Colorado Springs Notes, 1899-1900. 8½ x 11, soft cover, GBC punched, 182 pp.
- Dr. Nikola Tesla-Complete Patents-compiled by John T. Ratzlaff. Contains all 111 U.S. patents, plus one reissue. 8½ x 11, hard cover, 500 pp.
- Dr. Nikola Tesla-Selected Patent Wrappers from the National Archives (4 Vols.)-compiled by John T. Ratzlaff. Complete history of twenty of Tesla's most important patents. Contains new, unpublished material. Necessary information for completion and understanding of Tesla's inventions. 8½ x 11, soft cover, GBC punched, 922 pp.
- Part I-Solutions to Tesla's Secrets and the Soviet Tesla Weapons-by T. E. Bearden and Part II-Reference Articles for Solutions to Tesla's Secrets-compiled by John T. Ratzlaff A sensational and exciting breakthrough. The long searched for Tesla secrets have been solved by Tom Bearden. 8½ x 11, soft cover, 188 pp.
- The New Tesla Electromagnetics and the Secrets of Free Energy-by T. E. Bearden; Proof of Free Energy Devices and Supporting Data-by Dr. Rolf Schaffranke. The first major breakthrough in free energy. Soft cover, 35 pp. 8½ x 11.
- Toward a New Electromagnetics. Part III: Clarifying the Vector Principle-by T. E. Bearden. Extension of previous papers relating to Tesla technology. Soft cover, 8½ x 11, 33pp.
- Toward a New Electromagnetics. Part IV: Vectors and Mechanisms Clarified-by T. E. Bearden. Includes principles of virtual state (ether) technology leading to tapping of new energy source. Well illustrated. Soft cover, 8½ x 11, 62 pp.
- Video Tape - Solutions to Tesla's Secrets & The Soviet Tesla Weapons - by Tom Bearden. 2 hours. VHS or Betamax, ½".
- The Tesla Experiment - by Charles A. Yost. Earth harmonics found in lightning flashes. Confirms Tesla currents through the earth. New method of investigation. Soft cover, 8½ x 11, 38 pp.
- Transverse Paraphysics - The New Science of Space, Time and Gravity Control - by J. G. Gallimore. Completely new and fundamental concepts of matter, particle physics, gravity, anti-gravity and bio-physics. A most complete work. Soft cover, 8½ x 11, GBC punched, 359 pp.
- Harmonic Mathematics - A Phi-Ratioed Universe As Seen Through Tone-Number Harmonics -by William B. Conner. System of harmonic math establishes connection between Great Pyramid values, tachion motion, Walter Russell physics, and the work of Bruce Cathie. Soft cover, 8½ x 11, 46 pp.
- Part I-Math's Metasonics-Creativity Through Calculator Harmonic Braiding, and Part II-Music's Metasonics-Creativity Through Keyboard Harmonic Braiding, by William B. Conner, 2 volumes, 8½ x 11, soft cover, GBC punched, 353 pp. A blending of religious and scientific concepts in which chemical elements, nature and the universe are comprehended as calculated mathematical harmonics and musical tones.
- Electromagnetic Phenomena in Complex Geometries and Nonlinear Phenomena, Non-Hertzian Waves and Magnetic Monopoles-by Elizabeth A. Rauscher, Ph.D. A major mathematical breakthrough in properties of Tesla's non-Hertzian waves, point to development of communication systems. Soft cover, GBC punched, 8½ x 11, 141 pp.
- Tesla Said-compiled by John T. Ratzlaff. Includes 100 articles and papers in Tesla's own words, not previously published in book form. 8½ x 11, soft cover, 292 pp.
- Bedini's Free Energy Generator-by John C. Bedini. The first publication of details for building and operating a free energy unit. 8½ x 11, soft cover, 18 pp.

- Lightning in His Hand-by Inez Hunt and W. W. Draper, hard cover, 269 pp. Complete biography of Tesla's life and work - photographs.
- Prodigal Genius-by John J. O'Neill, soft cover, 326 pp. Complete biography of Tesla's life and work.
- Nikola Tesla-His Inventions, Researches and Writings-by T. C. Martin. Hard cover, 496 pp. This volume contains all of Tesla's early lectures, miscellaneous articles, discussions and inventions through the year 1894.
- Experiments with Alternate Currents of High Potential & High Frequency-by Nikola Tesla. Hard cover, 176 pp. A lecture delivered before the Institution of Electrical Engineers, London, and an appendix on The Transmission of Energy Without Wires.
- Nikola Tesla - Colorado Springs Notes 1899-1900. Hard cover, 440 pp. Important details of Tesla's experimental work. Contains approx. 200 drawings and 63 photographs.
- Nikola Tesla - Lectures, Patents, Articles. Soft cover, GBC punched, 1065 pp. 8½ x 11. Reprint of Tesla Museum publication.
- The Problem of Increasing Human Energy - by Nikola Tesla. Soft cover, 8½ x 11. Reprint of June, 1900, Century magazine article.
- Dr. Nikola Tesla - The Forgotten Superman of Our Age - by Ralph Bergstresser, 8½ x 11, soft cover, 15 pp. Review of Tesla's accomplishments.
- Nikola Tesla, Dreamer - by Allan L. Benson. Soft cover, 36 pp., 8½ x 11. His Three-Day Ship to Europe & His Scheme to Split the Earth, plus other articles and information.
- Introducing Nikola Tesla Through Some of His Achievements. Soft cover, 76 pp.. 7 x 8½. Includes articles, patents, photos, and bibliographical data.
- Enigma Fantastique - by W. Gordon Allen. Soft cover, GBC punched, 8½ x 11, 197 pp. An account of the work and the philosophies of Nikola Tesla and Rudolph Steiner.
- Return of the Dove - by Margaret Storm. Soft cover, GBC punched, 294 pp. Reprint. Spiritual interpretation of the lives of Nikola Tesla, Arthur Mathews and Otis T. Carr.
- The Wall of Light - by Arthur H. Mathews. Soft cover, 8½ x 11, 117 pp. Biographical notes on Nikola Tesla and an account of experiences of the author.
- Nikola Tesla Research. Soft cover, 8½ x 11, 64 pp. Assorted Tesla articles and information.
- Tesla - Man Out of Time - by Margaret Cheney. Prentice-Hall publication, hard cover, 450 pp. Recently published biography of life and work of Nikola Tesla.
- Nikola Tesla - Savant Genius of the 20th Century - by Anthony Shennan. Assorted articles and information. Soft cover, 8½ x 11, 39 pp.
- Ether Technology - A Rational Approach to Gravity Control - by Rho Sigma (Dr. Rolf Schaffranke). Basic background data on ether concept. Soft cover, perfect binding, 6 x 9, 108 pp.
- My Inventions - by Nikola Tesla, soft cover, 111 pp. Autobiography by Tesla, first appeared in issues of Electrical Experimenter magazine in 1919.
- Overlords and Olympians - by W. Gordon Allen. Introduction to Para-Psycho-Physics. Achievements of creative people, including Tesla. UFO discussion. Soft cover, 8½ x 11, 178 pp.
- The Cosmic Conspiracy-by Stan Deo. Sections on Tesla, evidences of the ether theory, gravity, classified activities in Australia, and age-old light and dark forces at work. 200 pp. Soft cover.
- Tuning In To Nature-by Philip S. Callahan. Fundamental information on solar energy, infrared radiation, and insect communication system. Includes important relationships to Tesla's work. 240 pp. Hard cover.
- The Soul of The Ghost Moth-by Philip S. Callahan. Traces author's development as a scientist and philosopher. Includes fundamental concepts of nature and reference to Tesla's basic works. 108 pp. Hard cover.

Write for price information
 Tesla Book Company
 1580 Magnolia Avenue
 Millbrae, CA 94030