

NIKOLA TESLA

On His Work With Alternating Currents

and Their Application to
Wireless Telegraphy, Telephony, and Transmission of Power

Leland I. Anderson, Editor

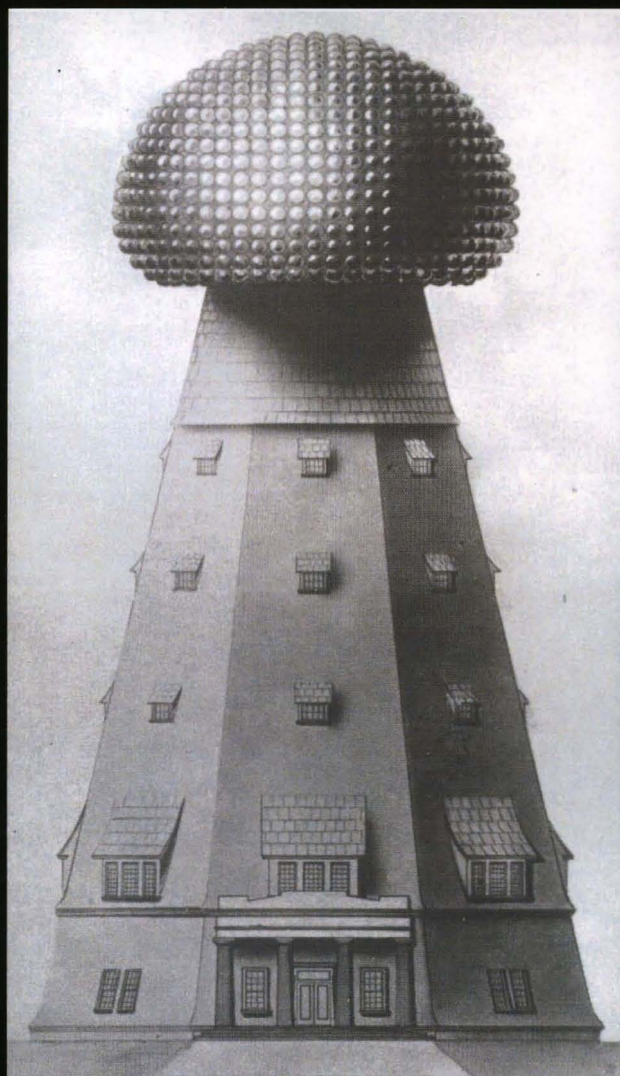
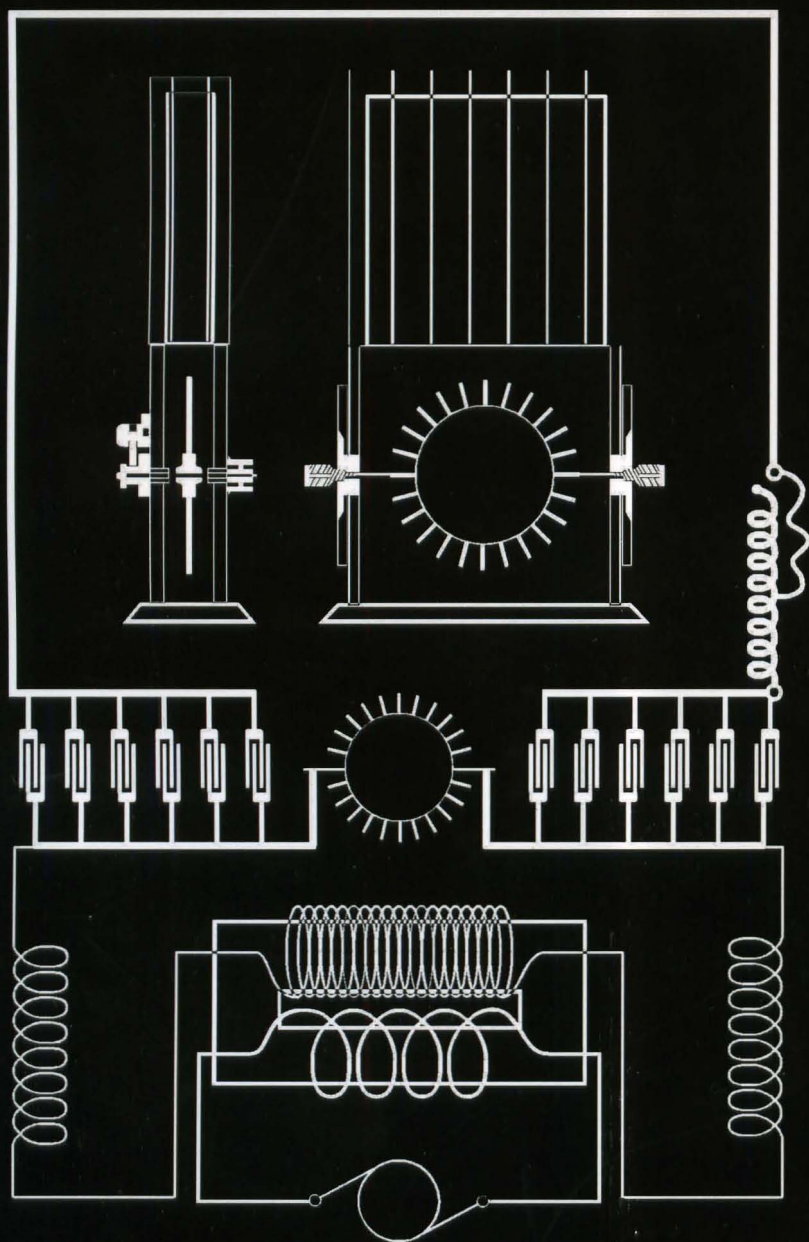

TWENTY FIRST CENTURY BOOKS

BRECKENRIDGE, COLORADO

**NIKOLA TESLA ON HIS WORK WITH
ALTERNATING CURRENTS**

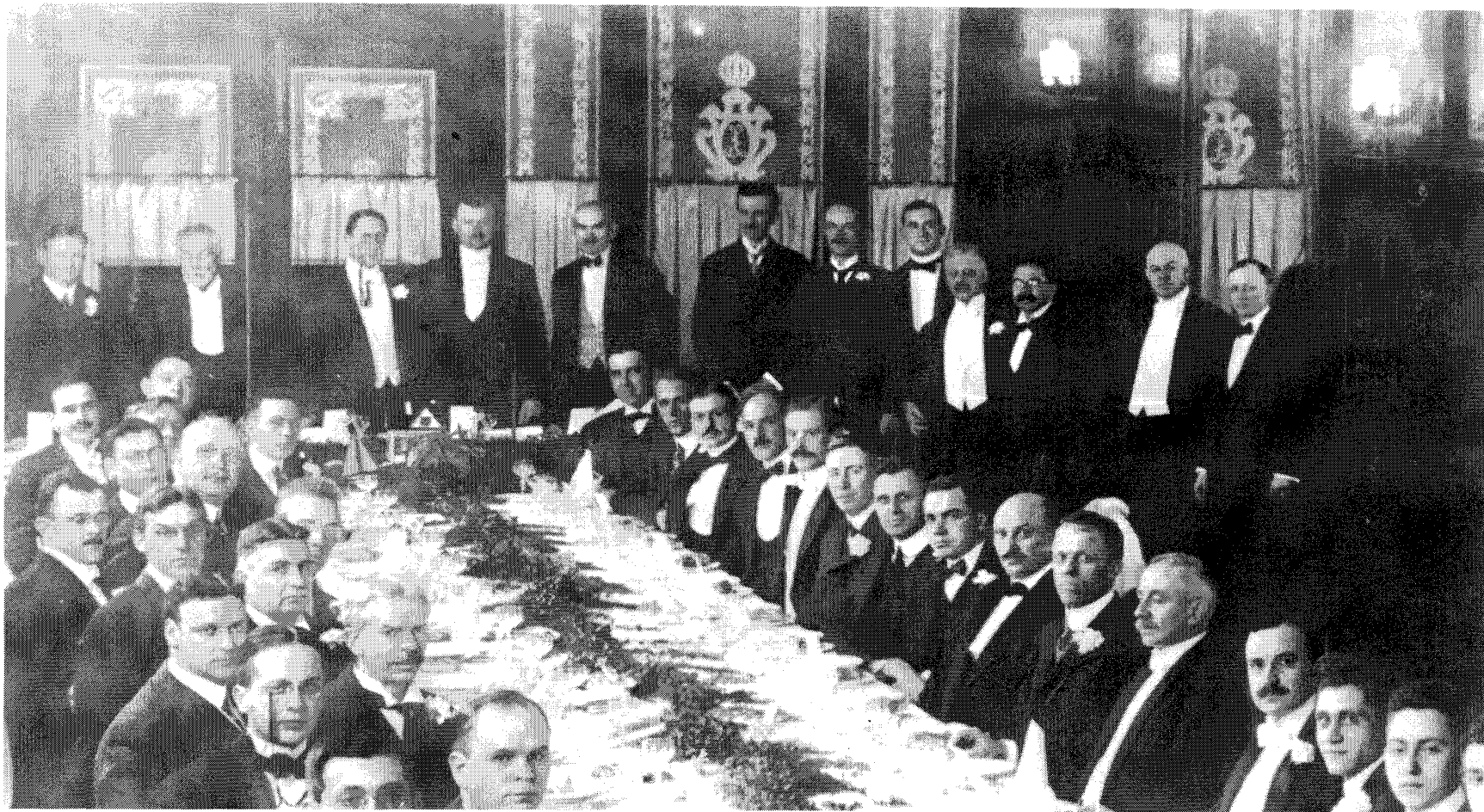

Second banquet meeting of the Institute of Radio Engineers (now part of the Institute of Electrical Engineers) at Luchow's in New York City, April 24, 1915.

Photo by C.A. Schere
Smithsonian Institution

Standing at back from left,

| George W. Pierce | Ferdinand Braun | John Stone Stone | Jonathan Zenneck | Lee de Forest | Nikola Tesla | Fritz Lowenstein | Alfred N. Goldsmith | Ernst F.W. Alexanderson |
|---|-----------------|------------------|------------------|---------------|--------------|------------------|---------------------|-------------------------|
| Tesla refers to these contemporaries in the interview at pages: | | | | | | | | |
| not mentioned | 103 | 16, 124 | 16, 133 | 100 | -- | 178, 179 | not mentioned | 24, 171 |

Tesla Presents Series
Part 1

**NIKOLA TESLA ON HIS WORK WITH ALTERNATING CURRENTS
AND THEIR APPLICATION TO WIRELESS TELEGRAPHY,
TELEPHONY, AND TRANSMISSION OF POWER**

An Extended Interview

Leland Anderson, Editor

2002

Twenty First Century Books
Breckenridge, Colorado

Copyright © 1992, Twenty First Century Books
All rights reserved. First Published 1992

Printed in the United States of America
by Fidler Doubleday, Inc.

No part of this book may be reproduced
in any form or by any means,
electronic or mechanical,
including photocopying, recording,
or by any information storage and retrieval system,
without permission in writing from the publisher.

Library of Congress Cataloging-in-Publication Data

Tesla, Nikola, 1856-1943.

Nikola Tesla on his work with alternating currents and their application to wireless telegraphy, telephony, and transmission of power : an extended interview / Leland Anderson, editor.

p. cm. -- (Tesla presents series ; pt. 1)

Originally published: Denver, Colo : Sun Pub., 1992.

Includes index.

ISBN 1-893817-01-6

1. Electric engineering--Patents. 2. Tesla, Nikola, 1856-1943--Interviews. 3. Electric engineers--United States--Interviews. 4. Telephone systems--United States--Patents. 5. Electric currents, Alternating. 6. Telegraph, Wireless. I. Anderson, Leland I. II. Title. III. Series.

TK257 .T48 2002

621.382'092--dc21

2002072006

Originally published by Sun Publishing, Denver
a subsidiary of
Boyle & Anderson, Denver, Colorado

Twenty First Century Books
Post Office Box 2001
Breckenridge, Colorado 80424

This work is dedicated to the late Philip D. Jordan, Professor emeritus of American history, University of Minnesota, who pressed his students to the review of legal records in historical research. “Indeed, few historians, librarians, and archivists recognize the significance of legal materials. . . . Yet the law, in one way or another, is the basis of most institutions—political, social, cultural, economic. . . . It is unfortunately a truism that graduate students are seldom introduced to legal materials.”*

* “In Search of Legal Records,” *The American Archivist*, Vol. 33, No. 4 (Oct. 1970).

CONTENTS

| | |
|---|------|
| Preface | xi |
| Introduction | xiii |
| Organization of Interview: | |
| Section | |
| I. High Frequency Alternators | 1 |
| II. Experiments with Wireless Telegraphy and Telephony | 9 |
| III. Mechanical and Electrical Oscillators | 36 |
| IV. Apparatus for Transformation by Condenser Discharges; Damped Waves | 48 |
| V. Apparatus for Transformation by Condenser Discharges; Continuous Waves | 76 |
| VI. Colorado Experiments | 88 |
| VII. Theory and Technique of Energy Transmission | 125 |
| VIII. Long Island Plant | 148 |
| IX. Arrangements for Receiving | 157 |
| X. Rediscussion/Clarification of Selected Remarks | 169 |
| Appendix | |
| I. Fig. 1. Photograph of Tesla with alternator in offices of The Westinghouse Electric & Manufacturing Co., May 10, 1938. [Ref. from p. 17.] | 181 |
| Fig. 2. Photograph of 1915 shipboard transmitter employing the Tesla spiral form of antenna transformer coil. [Ref. from p. 85] | 183 |
| II. Tesla's description of Long Island plant and inventory of the installation as reported in 1922 foreclosure appeal proceedings. | 185 |
| Index | 237 |

FIGURES

| Figure | | Page |
|--------|--|------|
| 1 | Diagrammatic illustration of first high frequency alternator with 384 poles. | 4 |
| 2 | Photographic view of alternator [shown in Fig. 1]. | 6 |
| 3 | Light and motive devices operated from this alternator in novel manner. | 7 |
| 4 | Vacuum tubes lighted in alternating electrostatic field. | 8 |
| 5 | Illustrating various ways of using a high frequency alternator. | 10 |
| 6 | Diagram of the second machine built with no wire on the rotating part. | 13 |
| 7 | Photograph of machine covered by U.S. Patent No. 447,921. | 16 |
| 8 | Diagrammatic drawing of the third and larger machine with 480 poles. | 18 |
| 9 | Photographic view of alternator covered by U.S. Patent No. 447,921. | 19 |
| 10 | Small alternator of very high frequency built for purposes of investigation (receivers). | 20 |
| 11 | Small high-frequency alternator of different construction, for the same purposes. | 20 |
| 12 | Diagrammatic illustration of machine with rotating magnetic field excitation. | 22 |
| 13 | Instrument to receive radio waves of 1896-1899 structure. | 25 |
| 14 | Electrical condenser described in U.S. Patent No. 464,667. | 30 |
| 15 | Electrical condenser described in U.S. Patent No. 567,818. | 31 |
| 16 | Improved form of electrolyte condenser as used in N.Y.C. laboratories. | 33 |
| 17 | Form of condenser with air under great pressure as dielectric. | 33 |
| 18 | Apparatus for manufacture of condensers and coils to exclude air. | 34 |
| 19 | Simple mechanical oscillator used in first experiments. | 36 |
| 20 | Mechanical oscillator with air spring combined with electric generator. | 37 |
| 21 | Another mechanical oscillator with controlling electromagnetic system. | 38 |
| 22 | Another type of small mechanical electromagnetically controlled oscillator. | 39 |
| 23 | Large electro-mechanical oscillator for generating isochronous oscillations. | 40 |
| 24 | Diagram of electro-mechanical oscillator for generating isochronous oscillations. | 40 |
| 25 | Double compound electro-mechanical isochronous oscillator. | 41 |
| 26 | Diagram of double compound electro-mechanical isochronous oscillator. | 42 |
| 27 | Large mechanical and electrical isochronous oscillator with four vibrating parts. | 43 |
| 28 | Diagram showing length of section of large mechanical and electrical oscillator. | 44 |
| 29 | Small high frequency mechanical and electrical oscillator used in many investigations. | 45 |
| 30 | Diagram of small high frequency electro-mechanical and electrical oscillator. | 46 |
| 31 | Method of transformation of electrical energy by oscillatory condenser discharges. | 49 |
| 32 | Series quenched spark gap. | 50 |
| 33 | Discharger working in hydrogen rich atmosphere, still further weakened by heat. | 51 |
| 34 | Oscillatory apparatus with interrupter in oil. | 53 |
| 35 | Apparatus with mechanical break as installed on a large scale in the N.Y.C. labs. | 55 |
| 36 | Isochronous mechanical break used in 35 So. Fifth Avenue laboratory. | 57 |
| 37 | Mechanical break with two oppositely rotating discs. | 58 |

| Figure | | Page |
|--------|---|------|
| 38 | Use of multi-phase generator with mechanical break. | 60 |
| 39 | Apparatus furnishing direct currents of high tension. | 63 |
| 40 | Apparatus and method of conversion by condenser discharges (both AD and DC). | 69 |
| 41 | Illustrating one of the early experiments with a tuned transformer. | 70 |
| 42 | Another illustration of an early experiment with a tuned transformer. | 70 |
| 43 | Apparatus illustrating the first step in the evolution of the magnifying transmitter. | 73 |
| 44 | One of many forms of mercury circuit controllers described in various U.S. Patents. | 76 |
| 45 | Hermetically sealed mercury circuit controller with compact oscillatory transformer. | 76 |
| 46 | Diagrammatic illustrations of hermetically enclosed mercury break. | 78 |
| 47 | Large mercury circuit controller of high frequency (communications experiments). | 79 |
| 48 | Interior arrangement of large mercury circuit controller of very high frequency. | 80 |
| 49 | Special type of high frequency transformer. | 82 |
| 50 | Illustrating forms of vacuum tubes. | 83 |
| 51 | Resonant wireless transmitting circuit. | 84 |
| 52 | Experiments illustrating transmission and transformation of energy through one wire. | 86 |
| 53 | Some of the most striking experiments with vacuum tubes and lamps. | 87 |
| 54 | The lighting of incandescent lamps by energy transmitted through one wire. | 88 |
| 55 | Experiment with the same apparatus in which a lamp is lighted at the end of a coil. | 88 |
| 56 | Another experiment with same apparatus in which the coil is not directly connected. | 89 |
| 57 | Oscillating apparatus on large scale with which the preceding experiments were made. | 91 |
| 58 | Experiment with coils tuned to harmonics. | 92 |
| 59 | Transmission of energy with tuned system by induction. | 93 |
| 60 | Application of the one-wire principle to the transmission of messages. | 93 |
| 61 | Illustrating an experiment with high frequency alternator and tuned circuit. | 94 |
| 62 | Wireless transmission demonstrated, mechanically elucidated. | 94 |
| 63 | Striking experiment in the transmission of energy by electromagnetic waves. | 95 |
| 64 | An important experiment in the transmission of energy performed in 1899. | 96 |
| 65 | Perfected system of wireless transmission with four tuned circuits. | 98 |
| 66 | Diagrams illustrating system of four-tuned circuits for wireless transmission. | 101 |
| 67 | Differences between Tesla apparatus and typical Hertz wave arrangements. | 104 |
| 68 | Powerful discharge from transmitter built following principles set forth. . . . | 111 |
| 69 | Experiment bearing upon design principles embodied in Tesla transmitter. | 113 |
| 70 | Experiment conveying idea of great quantity of electricity set in movement. | 114 |
| 71 | Wireless station at where experiments were performed. | 116 |
| 72 | Diagram showing general arrangement of transmitting and receiving circuits. | 116 |
| 73 | Experimental station at Colorado in a later phase of development. | 117 |
| 74 | Experimental station at Colorado showing investigative structure. | 118 |
| 75 | Discharge of a powerful transmitter under a pressure of 12 million volts. | 121 |
| 76 | Another discharge remarkable for symmetry at Colorado plant. | 122 |

| Figure | | Page |
|--------|---|------|
| 77 | Diagram illustrating use of sectional circuits. | 123 |
| 78 | Experimental demonstration in the Houston Street laboratory. | 125 |
| 79 | Diagram explanatory of transmission of electrical energy. | 129 |
| 80 | Diagram illustrating one of many wireless fallacies, from a Marconi patent. | 136 |
| 81 | Diagram illustrating mode of propagation of current from the transmitter. | 138 |
| 82 | Diagram illustrating law governing passage of current from the transmitter. | 139 |
| 83 | Improved transmitter described in U.S. Patent No. 1,119,732. | 144 |
| 84 | Transmitter at Wardencllyffe, erected for purposes of "world telegraphy." | 148 |
| 85 | Exterior view of the Long Island plant. | 149 |
| 86 | A view of some of the apparatus in the electrical part of the plant. | 150 |
| 87 | A view from a different direction. | 151 |
| 88 | Another interior view. | 152 |
| 89 | Another view showing some of the apparatus which has been described. | 153 |
| 90 | The first practical telautomaton, on principles in U.S. Patent No. 613,809. | 158 |
| 91 | Special clock, for purpose of measurements, especially useful in receiving. | 159 |
| 92 | Illustrating some of the attachments and mode of using same. | 159 |
| 93 | Devices for receiving as practiced in 1898-1900. | 160 |
| 94 | Other ways of receiving practiced in 1898-1900. | 162 |
| 95 | Illustrating bulbs made prior to 1900, many used in receiving apparatus. | 164 |
| 96 | Illustrating bulbs made prior to 1900, many used in receiving apparatus. | 164 |
| 97 | Illustrating bulbs made prior to 1900, many used in receiving apparatus. | 165 |
| 98 | Illustrating bulbs made prior to 1900, many used in receiving apparatus. | 165 |
| 99 | Illustrating bulbs made prior to 1900, many used in receiving apparatus. | 166 |
| 100 | Illustrating bulbs made prior to 1900, many used in receiving apparatus. | 166 |
| 101 | Static preventer. | 167 |

Appendix Figures

| | | |
|------|---|-----|
| A1-1 | A high-frequency alternator found in Westinghouse Electric & Manufacturing Company storage identified as belonging to Tesla. —Westinghouse | 181 |
| A1-2 | Shipboard quenched-spark transmitter, produced by the Lowenstein Radio Company and licensed under Nikola Tesla Company patents. —George Scherff | 183 |
| A2-1 | Construction detail of Wardencllyffe plant tower. —Lillian McChesney | 208 |
| A2-2 | Workshop on north side of Wardencllyffe plant building. —William Kolb | 222 |
| A2-3 | Generating room of Wardencllyffe plant building. —Bruce Kelley | 230 |

PREFACE

The surfacing of the transcript for this pre-hearing interview with Nikola Tesla by his legal counsel in 1916 resulted from an intensive search in archives of legal firms, some now defunct and others later acquired by contemporary interests. The interview was precipitated by numerous pending court cases as the fledgling radio industry entered a period of fierce competition. Tesla's counsel believed the interview necessary not only in order to prepare for the pressing of his own claims against the Marconi Company, but also to protect his own patent interests when called to give expert-witness testimony in the upcoming litigation foray pitting as adversaries a plethora of new communications companies and their captive radio pioneers.

A case prompting this interview, one of dozens to reach judicial review, was "Marconi Wireless Telegraph Company of America v. Atlantic Communication Company, *et al.*" Atlantic owned and operated the large radio station at Sayville, Long Island. The proceedings opened in 1915 with the calling of expert witnesses including Ferdinand Braun and Nikola Tesla. The specter of war had cast its shadow over Europe, and Count George von Arco, who had also been called, was detained because of services to the German Army in the use of asphyxiating gases and other deadly inventions perfected by him.

The text of this interview was, of course, never intended for publication. Counsel, concerned primarily with the protection of Tesla's patent interests, asks questions almost exclusively relating to the priority of his patents and their application. Tesla candidly discusses his contenders while presenting a thorough history of his work with alternating currents as applied to wireless transmission. In this document, he describes experimental methods, techniques, and apparatus used in his laboratories at New York City, Colorado Springs, and on Long Island.

Most of the photographs accompanying this interview are in good condition, but those of schematic and mechanical drawings have suffered some decay with time. These may be the only form of the drawings extant and are reproduced with as much fidelity as possible. For better clarity, five illustrations are reprinted from the February and May 1913 issues of the *Electrical Experimenter* magazine, Copyright © Gernsback Publications, where they subsequently appeared. These are figures 66, 67, 79, 81 and 82.

Although the interview spanned several days, it is presented in this work as though it was given at one time; all references to interruptions and resumptions have been removed. The text is printed in standard typewriter pica type, unjustified, in the style of hearing proceedings of that period. No alterations have been made in Tesla's remarks except for 'clean-up' additions, typically references to photographs and diagrams, and fill-in words necessitated by occasional rambling and incomplete sentence structure. These additions are provided in brackets []. Helpful notes are also cued to the text in brackets.

INTRODUCTION

*What I am going to show you, step by step, is how I proceeded
until I finally realized my dream. . . .*

Nikola Tesla

You are holding in your hands one of the most remarkable documents in the history of electrical science. Seldom, in technical research, has such a treasure of descriptive commentary and historical documentation been discovered. This book is a veritable Rosetta stone for deciphering and tracing the technical thoughts of one of the world's most distinguished engineering scientists since Archimedes. It describes electrical experiments which took place nearly 100 years ago—but have yet to be replicated.

So astonishing are its contents that it takes one's breath away!

Here, in Tesla's own words, are interpretations (couched in the language of 19th century physics) for electrical phenomena which even today lack satisfactory explanations in the language of modern technical analysis. Oh, it won't tell you how to wire up "the magnifying transmitter" (that arcane instrument for global wireless transmission),* but it will tell you what instruments Tesla was employing, what his thoughts were, how he conceptualized things, how he proceeded, where he performed his historic experiments, when key results were obtained, and how he reached his conclusions.

Tesla, himself, was awe-struck with the results of his scientific endeavor. He expressed astonishment then at what he later asserts is experimentally demonstrable. Listen to the words he uses in this interview to describe the electrical phenomena to his attorney: "magnificent," "it was a marvelous sight," "a wonderful thing," "practically the lamp of Aladdin," "a tremendous display," "glorious," "so marvelous that one would be almost afraid to talk about them . . ." An Edmund Spenser or a John Milton could be no more eloquent. One of Shakespeare's characters once said, "Bid me discourse, and I will enchant thine ear." Tesla does no less, even in a legal briefing. He weaves the gossamer web of enchantment—which yet thrills our technical imagination and lures us in, nearly 80 years after a stenographer recorded these spoken words!

Who was Nikola Tesla?

In 1896, at the Franklin Institute in Philadelphia, Lord Kelvin said, "Tesla has contributed more to electrical science than any man up to his time." After showering words of praise upon the inventor before a meeting of the Royal Society in London in 1892, Lord Rayleigh declared that Tesla possessed a great gift for electrical discovery. Fortunately, the text of Tesla's speech has been preserved and republished.^{1,2,3} He was one of the earliest scientists to understand the distinction between lumped and distributed resonance and the first to patent voltage magnification by standing waves.

* It may just be that there *is* enough information present to solve the puzzle of the magnifying transmitter. The reader will have to dig for himself.

The unit of magnetic induction is named in honor of Tesla. It is commonly understood by power engineers that he was the inventor of the induction motor utilizing the rotating magnetic field and the AC polyphase power distribution system currently used throughout the civilized world.* However, most electrical engineers are unaware that, as late as 1943, he (not Marconi†) was recognized by the U.S. Supreme Court as having priority in the invention of “radio.” Even fewer computer scientists are aware that, when certain computer manufacturers attempted to patent digital logic gates after World War II, the U.S. Patent Office asserted Tesla’s turn-of-the-century priority in the electrical implementation of logic gates for secure communications, control systems, and robotics. As a result, a monopoly on digital logic gates in general was unable to be secured in the 1950s.

Tesla served the electrical engineering profession in its highest offices. In the early 1890s, he was elected as vice-president of the American Institute of Electrical Engineers, now the Institute of Electrical and Electronics Engineers. At the time of his election, Alexander Graham Bell was its president. Tesla served two years as vice-president of the AIEE and, a decade later, one of his laboratory technicians at the Colorado Springs experiments served as the first vice-president of the Institute of Radio Engineers when it was formed in 1903. This was the now, famous consulting engineer Fritz Lowenstein. Lowenstein was the inventor of the grid biased Class A amplifier (for which he received the sum of \$150,000 from AT&T in 1918),⁴ the shaped plate capacitor, and other electrical and mechanical devices. His two IRE papers, with comments on the propagation of ground waves by Zenneck and sky waves by Austin, appeared in February and June issues of the IRE Proceedings, the year of this interview. It should also be noted that Tesla was a fellow of the AIEE, the American Association for the Advancement of Science, and a dozen other professional societies. He received over 13 honorary degrees from such diverse institutions as Columbia, Yale, and the Universities of Paris, Vienna, Prague, and Sofia.

Recently, another fascinating fact about Tesla has come to light. After all these years, it is now known that he was nominated for an *undivided* Nobel prize in physics in 1937.⁵ Tesla’s nominator, Felix Ehernhaft, of Vienna, had previously nominated Albert Einstein for the Nobel prize.

* Charles E. Scott, past president of the AIEE has said, “The evolution of electric power from the discovery of Faraday in 1831 to the initial great installation of the Tesla polyphase system in 1896 [at Niagara Falls] is undoubtedly the most tremendous event in *all* engineering history.” [*Electrical Engineering*, August, 1943 (Vol. 62, No. 8), pp. 351-355.]

† Although it took the courts several decades to figure this out, the facts were well understood by impartial technical men of the day. Robert H. Marriott, the first president of the IRE, once said that Marconi had, “. . . played the part of a demonstrator and sales engineer. A money getting company was formed, which in attempting to obtain a monopoly, set out to advertise to everybody that Marconi was the inventor and that they owned that patent on wireless which entitled them to a monopoly.” [*Radio Broadcast*, December, 1925 (Vol. 8, No. 2), pp. 159-162.]

Tesla had the remarkable talent of charming and astonishing his admirers while at the same time enraging his enemies—the phenomenon continuing to the present day. It is unfortunate that, despite several current popular biographies, there still exists no definitive technical authority, other than his own scattered publications, to consult on the scientific issues of his intriguing and colorful scientific career. Consider the adulation bestowed upon him by Lord Kelvin, Hermann von Helmholtz, Sir William Crookes, Lord Rayleigh, Sir James Dewar, Robert Millikan, Sir James Fleming, B.A. Behrend, A.E. Kennally, L.W. Austin, W.H. Bragg, Ferdinand Braun, Jonathan Zenneck, E.W.E. Alexanderson, J.S. Stone, Vannevar Bush, W.H. Eccles, Edwin H. Armstrong (who served as a pallbearer at Tesla's funeral, as did Alexanderson), and notably Albert Einstein, Ernest Rutherford, Arthur Compton, and Neils Bohr. There are a number of Nobel laureates, Royal Society fellows, IEEE presidents and fellows, and university presidents in that collection. No one, since Franklin, had so stirred the scientific and engineering world.

In 1893, Thomas Commerford Martin, the third president of the AIEE (1888-1889), edited and published a remarkable collection of Tesla's contemporary lectures. It is in print today, and a century from now it will still be considered an unparalleled classic in scientific literature to be read along with Franklin's *letters*, Priestly's *history*, Faraday's *researches in electricity*, Maxwell's *treatise*, Hertz's *electric waves*, and Heaviside's *electrical papers*. In 1919, 26 years after publishing the work on Tesla, Martin wrote,

Tesla's influence may truly be said to have marked an epoch in the progress of electrical science. Very little data, however, has been procurable that is descriptive of his later researches, and more is the pity from the historical standpoint. Tesla has not finished. The world waits expectantly for each fresh touch of his vitalizing thought upon the big electrical problem of the age. ⁶

Unlike most of the aforementioned scientists, Dr. Tesla—for so it is appropriate to call him—had no financial support to fall back on from a faculty position or research institute. His ideas had to support themselves and him in the technical marketplace. It is not surprising, therefore, that he felt no compulsion to share further technical details in the open scientific literature of his day. For these you must dig (and dig, and dig) through the patent literature, where only enough is disclosed to make it clear to one “skilled in the art.”

Readers will also be struck with Tesla's lighter side. His sense of humor and his quick wit shine through when he describes his 1893 RF demonstration before the public at the Sixteenth Convention of the National Electric Light Association in St. Louis, where he was distinguished as honorary member: “There was a stampede in the two upper galleries and they all rushed out. They thought it was some part of the devil's work.” (p. 87) His humor is also evident in his description of the influence that his demonstrations had upon the Royal Institution in London in 1892: “The scientists simply did not know where they were when they saw it.” (p. 95)

Tesla could also be sarcastic: “The greatest men of science have told me [the Tesla coil] was my best achievement. . . . For instance, a man fills this space with hydrogen; he employs all my instrumentalities, everything that is necessary, but calls it a new wireless system—I cannot stop it. Another man puts in here a kind of gap. *He gets a Nobel prize for it.* . . . The inventive effort involved is about the same as that of which a 30-year old mule is capable.” (p. 48)

Electrical History

For those deeply active in the technical evaluation of historic electrical research, it is a source of intense frustration and shattering disappointment to find “a new book” or even have a television “documentary” appear, only to discover that the authors (a) didn’t penetrate the technical aspects of their subject sufficiently to understand what the real issues were, and (b) continue to perpetuate unsubstantiated popularized assertions, myths, and historical errors ‘generated at victory balls’ and not at the scene of the battle. This is especially true of authors addressing topics in the realm of RF, antennas, and distributed circuits (i.e., radio) where merely an academic knowledge of electronics or Maxwell’s theory is insufficient to guarantee professional livelihood in those disciplines. It leads one to conclude that no reliable history of this research can be written until those with adequate technical training and experience devote their time and effort to the subject.

But this document is a breath of fresh air. It sets straight a region of the radio history puzzle which has been incongruous for over nine decades. When we saw these pages, our first impulse was to start an immediate technical evaluation: replicate apparatus, search for partially disclosed concepts and missing pieces, clarify issues, and execute a technical analysis.

We believe that this document will initiate considerable activity along these lines, performed as well by a broad spectrum of investigators. This introduction is not an appropriate medium to discuss such pursuits. Instead, we invite the reader to consider the wonderful personal narrative which will be placed before him.

Feel the pathos in Tesla’s voice as he describes the famous system of four-tuned circuits: *Every wireless message that has ever been transmitted to any distance has been transmitted by this apparatus; there is no other way.* Twenty-seven more years would pass before the highest courts of the land would echo in agreement. From those legal proceedings would emerge the acid test for any radio system. For this reason, Tesla, not Hertz, Marconi, or De Forest has been given the title *inventor of radio*. The courts clearly exercise a distinction between “innovation” and “invention.” How strange that, even at this late date, there are those that still don’t understand what happened.

Fresh Surprises from Tesla

Tesla has never lost the magical touch. Even today, exactly 100 years after his lecture at the Royal Institution (London), his careful engineering skill still has power to surprise and delight a technical audience. But what was unexpected from Tesla—today, in 1992, is a fresh glimpse of his life’s work. Those of us that have toiled with RF technology, and electromagnetic radiation and propagation owe a great debt to Anderson, one of the world’s leading authorities on Tesla, for publishing this remarkable document. It is absolutely unique. We have no doubt that it is destined to join *My Inventions; Lectures, Patents, and Articles; Und Sein Werk; Invention, Researches and Writings*, and *Colorado Springs Notes* as a member of the historic “canonical Tesla publications.” Anyone doing a serious technical evaluation of Tesla’s research must turn to these works.

Return to 1916

It is important to grasp the pulse of society at the time of this interview. In your mind's eye, return to the era of 1916. A Princeton history professor named Woodrow Wilson, the same age as Tesla, will be re-elected to lead the country. War has been raging in Europe for the past 18 months. The Lusitania has been sunk. Within a year, the U.S. would declare war on Germany and more than 100,000 young Americans would go “over there” never to return home to their loved ones. Irving Berlin is writing songs, 24 states have voted-in prohibition, and Ford has produced his millionth automobile. Motorized taxis have just appeared on the streets of New York, and electricity has made possible the new skyscrapers that now begin to dominate the city's skyline.

On Mount Wilson, in California, the new 100-inch telescope is nearing completion. In Europe, Albert Einstein has just introduced the general theory of relativity, and astronomer Arthur Stanley Eddington is quietly preparing expeditions to islands off the coast of Africa and Brazil to test the theory during a solar eclipse. Consultant John Stone Stone has just completed his term as president of the IRE, and Harvard Professor A.E. Kennelly has stepped into the position—he had previously served as president of the AIEE in 1898. The IRE now has almost 1,000 members. Dr. Zenneck's treatise on wireless telegraphy has just appeared, and he will soon be held “under arrest” at Ellis Island for the duration of WWI. Zenneck would later serve as vice-president of the IRE during 1933.

At Bell Labs, John R. Carson has just shown that single-sideband transmission is mathematically possible. The first transcontinental telephone link has just been demonstrated between Alexander Graham Bell in New York and Thomas A. Watson in San Francisco, and wireless service between the U.S. and Japan has been inaugurated. In 1916 the electromagnetic spectrum is populated only by amateurs and commercial telegraph stations. There is yet no commercial AM broadcasting, although Frank Conrad, who would be vice-president of the IRE 11 years later, has just built an amateur station. It would become Westinghouse's KDKA in November, 1920.

Tesla has recently published “Some Personal Recollections” in the *Scientific American*. He has proposed that the Secretary of Defense create a Defense Science Board. Looking toward the future, he publishes an essay called, “The Wonder World to be Created by Electricity.” E. Taylor Jones and W.M. Jones have published, in the *Philosophical Magazine* (London), erroneous lumped-circuit analyses of Tesla coils. Nineteen years later, one of E.O. Lawrence's proteges at Berkeley would declare, in pages of the *Physical Review*, that Tesla coils “cannot be treated usefully by mathematics.”

Tesla prophesies that radio-controlled torpedoes and missiles will soon expose the general population, not just the military, to the horrors of war. In 1916, the *Scientific American* discusses Tesla's new automobile speedometer, the tower at Shoreham (Long Island) will pass from his hands, and Hugo Gernsback's magazine, the *Electrical Experimenter* will contemplate his Colorado Springs experiments. Princes Lwoff-Parlaghy entertains Tesla among New York socialites, and her painting of Tesla appears in *The New York Times*. It will later appear on the cover of *Time* (July 20, 1931).

A Visit to a Law Office

As an unseen guest, you have been ushered into an oak-decorated law office in New York City. Before you sits Nikola Tesla, now 60 years old, still with bushy black hair, slight wrinkles beginning to form around his piercing light blue-grey eyes. He possesses a winning smile and a firm handshake. He wears no jewelry or watch fob. He has a somewhat high-pitched, reedy voice, and speaks quickly and convincingly. He is still very much the cosmopolitan New Yorker in his speech, manner, and demeanor. He has brought with him numerous drawings, papers, and photographs for reference.

Across a wooden table sits his attorney. His demeanor is professional and serious, his questions are penetrating, his manner is deliberate. He is well aware of the professional reputation and international regard of the esteemed gentleman that sits before him, and he is intent upon understanding every detail that he can turn to his client's advantage in the dramatic contests at law which will soon occur. Also present is a stenographer, intent upon providing the attorney with an accurate written transcription of every thought which will soon unfold. The formalities being over, the counselor begins to speak. . . .

K.L. Corum* and J.F. Corum, Ph.D.†
April 4, 1992

References:

- (1) Martin, T.C., *Inventions, Researches and Writings of Nikola Tesla*, The Electrical Engineer, New York, 1893; ch. 27, pp. 123 and 198-293, "Experiments with Alternate Currents of High Potential and High Frequency" by Tesla, February, 1892. This book has been republished and is available from several sources.
- (2) Popovic, V, Horvat, R., and Nikolik, N., eds., *Nikola Tesla: Lectures, Patents and Articles*, Nikola Tesla Museum, Beograd, Yugoslavia, 1956; ch. 3, "Experiments with Alternate Currents of High Potential and High Frequency" by Tesla, pp. L48-L106.
- (3) Tesla, Nikola, *Experiments with Alternate Currents of High Potential and High Frequency*, McGraw Publishing Co., New York, 1904, 162 pp.
- (4) Discussion of "A History of Some Foundations of Modern Radio-Electronic Technology," Comments by Lloyd Espenschied, *Proceedings of the IRE*, July, 1959 (Vol. 47, No. 7), pp. 1254, 1256.
- (5) Crawford, E., Heilbron, J.L., and Ullrich, R., University of California, 1987.
- (6) Martin, T.C., and Goles, S.L., *The Story of Electricity*, The Story of Electricity Co., Vol. 2, 1919, p. 107.

* Corum & Associates, Inc., Thornton, Hew Hampshire
† Battelle, Columbus, Ohio

Counsel

Please recount the history of your work with alternating currents and their application to wireless telegraphy, telephony, and wireless transmission of power.

I. High Frequency Alternators

Tesla

Work on high frequency alternators was begun by me in 1888, in my laboratory at 89 Liberty Street. I had just completed my system of power transmission, which is now universally adopted, but several problems yet remained to be solved. One was to run my induction motors at very high speeds; another one was to adapt them to the then existing alternating circuits of supply of 133 cycles. These two problems, although they were diametrically opposite, both required the use of laminated structures with a great many poles or polar projections, and I constructed quite a number of these with the object of improving along the lines indicated.

Among these was an alternator with 24 poles, which gave me 12 cycles per revolution. This I used originally in running some small induction motors at speeds up to 200 [revolutions] per second. Occasionally, however, I would use this alternator in other experiments, with transformers, etc., and condensers, and then by running it at high speed (10,000 RPM) developing something like 2,000 cycles [per second], which phenomena were entirely new. This, of course, interested me very much, but the work was interrupted in 1888 when I had to go to Pittsburgh to attend to the manufacture of the motors.

On my return to New York the next year, that was early in 1889, I engaged a laboratory at 175 Grand Street, close to Center Street, and there is where I undertook to design and construct the first high frequency machines.

I had at that time already perceived enough to get the idea that energy could be transmitted without wires. It was of no consequence to me at that time whether it was to be used for telegraphy, or telephony, or power transmission. I was on the problem of transmitting energy without wires; and as it is my custom always to analyze scientifically every problem that I undertake to solve, I devoted a great deal of thought to how to attack that problem, and the following crystallized out.

It was evident to me that wireless transmission of energy, if it could ever be accomplished, is not an invention; it is an art. Bell's telephone, Edison's phonograph, or my induction motor were inventions, but the wireless transmission of energy is an art that requires a great many inventions in combination.

We are living on a planet that is rushing through space; this planet is partly conducting and partly insulating. If it were all conducting, or if it were all insulating, we could not transmit energy without wire. It is only because it is partly conducting and partly insulating that a glorious future for man is reserved through the application of this art.

The steps to be taken which I recognized then as absolutely necessary were, first, that I had to produce electric oscillations of the required character. Now, granted that I had them, it still remained to be shown how these oscillations could be transformed into some sort of vibratory energy capable of penetrating into the distance. Therefore, the second step was the transformation of these oscillations into such form of energy as would go to a distance: To develop methods of and apparatus for reception, to collect the energy at any point, was the third step. The fourth step was to isolate the energy. If I simply transmitted energy in all directions without regard to its use, then that energy would be simply lost in space, and it would be no economical system. Consequently, I had to devise means to isolate that energy, and this problem again presented itself in two aspects, active and passive; that is, I had to make the transmitter noninterfering, and I had to make it noninterferable. Those are not two identical problems, but both had to be solved. Finally, as to the fifth step, I found that we could never transmit energy, or construct our machines and apply them with understanding, unless we discovered the laws according to which this energy flows through the planet, laws which would enable us to calculate accurately the energy we are to receive at any point, and to design our machines to suit the work.

In reviewing these objectives, what I am going to show you, step by step, is how I proceeded until I finally realized my dream, and, in 1899, produced a transmitter of greater power than probably all the combined transmitters put up today, and, furthermore, perfected an apparatus by which unlimited energy can be transmitted very economically, thousands of horsepower if necessary, from one small, compact plant, much smaller than that at Sayville or Tuckerton.[*]

* Editorial note: The large German-owned radio station at Sayville, Long Island, was constructed by Telefunken (Gesellschaft für Drahtlose Telegraphie) a few years prior to WWI for communication with a station at Nauen, near Berlin. Suspected of rendering non-neutral service at the outbreak of hostilities, it was taken over by the U.S. Navy Department in July, 1915. The great Tuckerton, New Jersey, radio station was built by the Homag Company (Hochfrequenz-Maschinen

The drawing [Fig. 1] shows the first step toward the evolution of a generator, or transmitter, which may be used to flash energy to distances, under practical and economical conditions. This machine was described by me in U.S. Patent 447,920, of March 10, 1891.

It was the first high frequency alternator that was exhibited, and with which tests were made in public, although I had made alternators of high frequency, as I said before, as far back as 1888. This was a machine from which I could get from 10,000 to 20,000 cycles. We used to say, in old times, "alternations"; this term has been loosely employed.

There has been an impression produced that my early machines were rather experimental; but as a matter of fact, the design and construction of machines was my specialty and, prior to undertaking this, I had spent eight years in doing nothing but designing machines. Therefore, the results which I showed with this machine, and which I put before the world in 1891, are results with a machine that I could not, with all my present knowledge and experience, and all the devices of the art, improve one-half of one percent. And any other engineer, no matter who he be, would have that same hard time as myself because in this machine I embodied every little device that was available. I utilized to the full and got the maximum out of the materials. I had the lowest armature resistance which could be obtained, I had the lowest self-induction, I had the highest periphery speed, I had the greatest output, far greater than any alternator that has ever been built since that time. In fact, I united in this machine features which no other that has been designed since has ever combined.

Furthermore, the currents I developed were perfectly sinusoidal. That may have been known to other experts, that the currents should be sinusoidal, because that follows from certain theoretical researches; but remember that I had invented the "rotating magnetic field," that the very production of that field was based on the use of quantities which wax and wane alternately in accordance with the law of the sine as, I have pointed out in a paper read before the American Institute of Electrical Engineers in 1888, when I presented my induction motor before that body. Therefore, everything was done in this machine that could be done to secure advantage by every possible device known to engineering.

Aktiengesellschaft für Drahtlose Telegraphie) for the Compagnie Generale de Telegraphie sans Fil of France, but the German firm delayed transferring ownership after the outbreak of hostilities. It, too, was taken over by the U.S. Navy Department, September, 1915. (See: Howeth, L.S., History of Communications-Electronics in the United States Navy, U.S. Government Printing Office, 1963; pp. 225, 526.) Tesla was a technical consultant to the Tuckerton station and received monthly royalty payments on its operation until it was taken over by the U.S. Navy Department.

(No Model.)

N. TESLA.
METHOD OF OPERATING ARC LAMPS.

No. 447,920.

Patented Mar. 10, 1891.

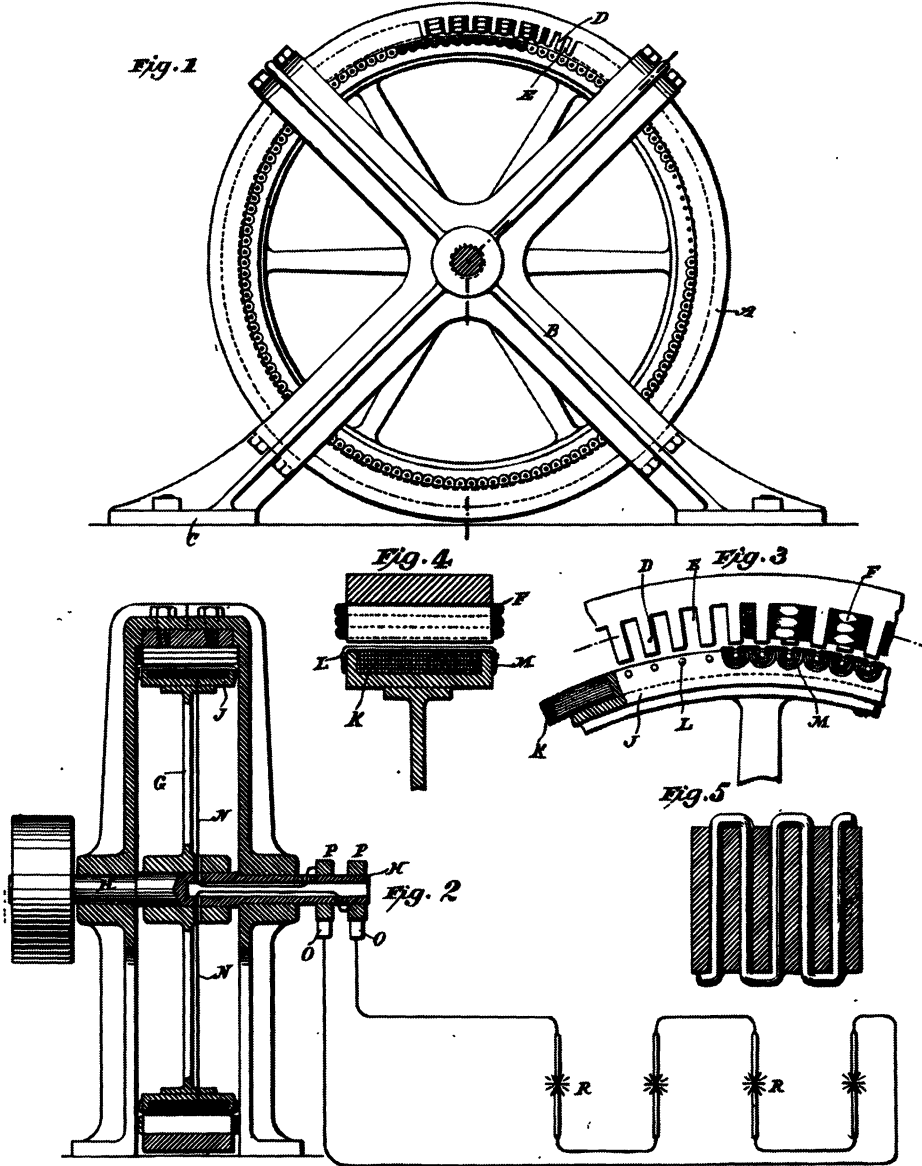

Witnesses:
Raphael Netto
M. G. Tracy

Inventor
Nikola Tesla
 by *Duncan & Page*
 Attorneys

Figure 1.
 Diagrammatic illustration of first high frequency alternator with 384 poles, patent application filed October 1, 1890, also in book "Inventions, Researches and Writings of Nikola Tesla" by T.C. Martin, published by the Electrical Engineer, New York, 1893, Figs. 199-203, pp. 375-376.

Referring to the drawing [Fig. 1], I employed a ring of the finest iron, and a steel disc with a peculiarly arranged ring, capable of rotating at 1,400 feet per second, safely. No such velocity has ever been approximated in any alternator. I had, furthermore, an armature resistance in this machine of only 0.5 ohm. If I would have had, say, 6 ohms, which is typical of such an alternator, the machine would have been burned out. Even at 0.5 ohm, I had a hard time to operate it when I really had the greatest resonant rise.

I used a trick [in this machine] which enabled me to get a big output, and you will see how I accomplished it. I constructed my rotor with just one layer of thin wire, and by a special process I baked this wire so that it formed a solid mass with the rotor, and the centrifugal force, no matter how high the speed, could not tear it off. Then I made my field very small. The result of this was that I had a tremendous ventilation which enabled me to put through the field a current of 25 or 30 amperes per square millimeter, and out of the armature I could easily take 30 amperes per square millimeter. You know, in machine design, if you take out four to four-and-one-half amperes per square millimeter, that is a great performance. I defy anyone to take out of the conductor [of these conventional machines] more than five or six amperes per square millimeter. But, I designed this machine so that I could have 30 amperes per square millimeter in the armature and nearly 30 amperes per square millimeter in the field on account of the great ventilation.

So, therefore, when I show this machine, I have shown the most advanced machine in wireless that has ever been produced up to this date. People, of course, have managed to use a turbine, but that is a subsequent development. If I had had a turbine to drive this machine, I would have done much better. Later on, however, I will show you a machine which I designed specifically for the turbine. I have recently heard that, as a result of years of work [emphasis by Tesla], Hogan [*] reported that they came to just exactly the same machine which I exhibited in 1892 and 1893, with which I showed experiments to Helmholtz, and which was a piece of apparatus known all the world over from pictures; yet they have been doing nothing for years and years but experimenting in this particular field.

This machine [Fig. 2] was exhibited before the American Institute of Electrical Engineers, where I showed my first experiments, and in these experiments, as I shall state in a few

* Editorial note: Reference is to John V.L. Hogan, at that time chief research engineer, National Electric Signaling Company, who was one of the driving forces in the forming of the Institute of Radio Engineers, later becoming its president in 1920. The "they" refers to the work of the General Electric Company's Steinmetz, Berg, Green, and Alexanderson, in collaboration with Fessenden of the National Electric Signaling Company, leading to the production of successful alternators operating up to 60 kHz at 100 kW.

words, I obtained some striking results, which were the starting point of this whole development.

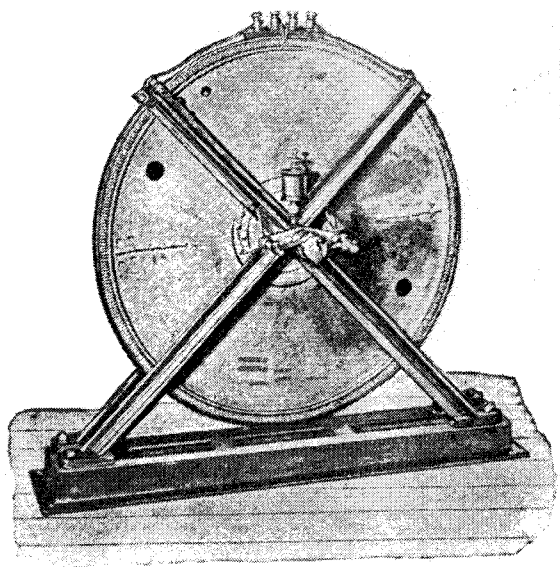

FIG. 97.

Figure 2.
**Photographic view of alter-
 nator [shown in Fig. 1].
 Illustration from Martin
 book, Fig. 97, p. 153.**

Unfortunately, that [Fig. 2] is a reproduction from the only picture I have. This machine was destroyed in the fire that annihilated my laboratory in the Spring of 1895, and I had nothing left of it but a little piece. That photograph [was] taken from an old, very poor print; but it shows the general arrangement of the machine.

This machine I operated at Columbia College with about 5,000 cycles; later on I attained 23,000 cycles running it at a higher speed, and it was in every way a most satisfactory piece of apparatus. It was used by me in experiments with wireless telephony, telegraphy, and all sorts of experiments until it was destroyed.

When I published the results with this machine, I did not have the courage to run it as high as I wanted to so I operated only at about 3,000 or 3,600 revolutions and then I could get out of it approximately 4 kilowatts. But I could easily get out of it 12 or 13 kilowatts later on. This large output was only made possible through the tremendous ventilation. I remember that at Columbia College, Mr. [Gano] Dunn, who is now Vice-President of the White Company, I believe, and who was assisting me in the lecture, forgot to turn off the current in the field when the machine was stopped, and if I had not shut it off, the field would have burned out. This high output I could only get through this artifice.

It was a fine machine, and I really do not see how anybody could produce a better device for the purposes of

radio telegraphy. There is no such thing. I have designed other machines which are, perhaps, better in some respects. This machine is extremely serviceable.

There were two striking results which I showed in my lecture at Columbia College, and I will illustrate them because I wish to show these various ideas from their starting point.

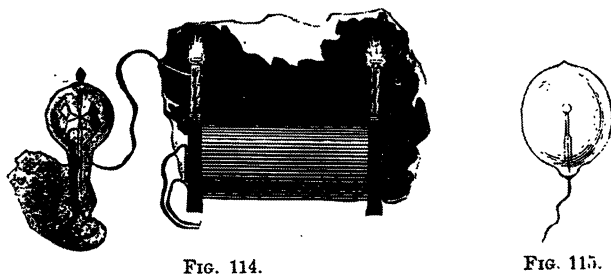

Figure 3.
**Light and motive devices operated from this
 alternator in novel manner. Illustration
 from Martin book, Figs. 114 and 115, p. 177.**

The first result [Fig. 3] was one of the experiments which I at that time showed in a public lecture, motive devices operated by merely connecting them to one terminal of a source of oscillations -- a high frequency coil. I have often been told that my most important results in invention was the demonstration of the practicability of transmitting energy over one wire; because, once we can transmit energy over one wire we can use also the earth, for the earth is equivalent to a large conductor -- a better conductor than copper wire. This was one of the results I got, but the most striking one I will show you now.

This second result [Fig. 4] shows how energy goes through space without any wire. That was a most striking experiment which was repeated all the world over and was published in thousands and thousands of papers. There is a field produced -- of high frequency -- and in this field I hold two tubes of glass in my hands. These glass tubes spring into powerful light. That was an experiment which carried the whole world by storm; but to me it was the first evidence that I was conveying energy to a distance, and it was a tremendous spur to my imagination and to my energy to develop what I had started.

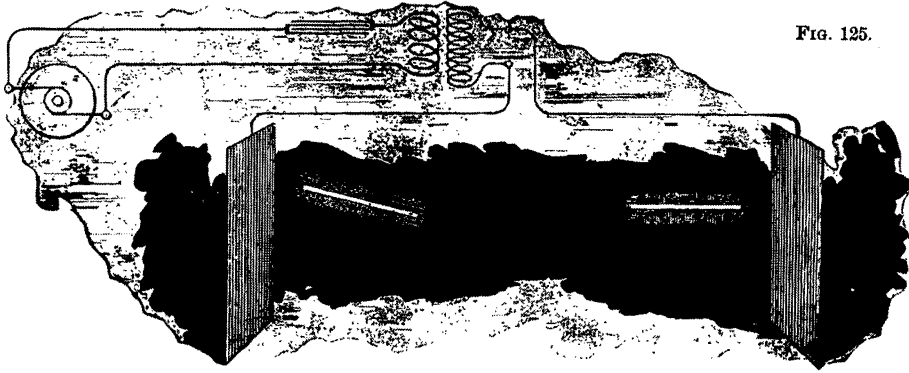

Figure 4.
Most striking results obtained -- vacuum tubes lighted in
alternating electrostatic field. Illustrated in Martin book,
Fig. 125, p. 188.

II. Experiments with Wireless Telegraphy and Telephony

Tesla

[Diag. 1 of Fig. 5] shows how I used this machine which I have described in my first efforts toward wireless. These experiments were all performed in my laboratory on Grand Street, but they were subsequently very much refined and carried on in a different way.

Counsel

What date was that?

Tesla

That was in 1891, prior to my going to England to lecture before the scientific societies there, the Royal Institution and the Institution of Electrical Engineers. I had a wire run out through the window, and placed on the roof all sorts of devices to constitute this capacity [shown in the diagrams as an elevated square]. The first step was to connect this alternator [shown in the diagrams as a circle] with one terminal to the water pipe system and the other end to the antenna. I had already proved in my lecture at Columbia College that I could transmit energy through one wire; therefore, I was prepared to find that a current of considerable strength could be passed through this wire here [connecting the alternator to the elevated capacitor], although it was insulated. My idea at that time was that I would disturb the electrical equilibrium in the nearby portions of the earth, and the equilibrium being disturbed, this could then be utilized to bring into operation in any way some instrument. That was what we would now call, simply, impressing forced vibrations of very high frequency on an antenna. We have introduced the term "antenna" since that time.

The second step was as shown [in Diag. 2 of Fig. 5]. You will notice that I have inserted a coil in the circuit. The necessity for that coil arose from the fact that I could not get a capacity big enough to tune the system properly to the frequency of the alternator. I had advocated in the beginning a very large capacity, and you will note that in my expositions of that period, from 1891 to 1893, I insisted on the very largest capacity that could be obtained because, according to my theory, which has since, of course, been confirmed, the amount of current that flows through such a system is proportionate to that capacity. Therefore, as the effect in the distance is proportional to that current, I had to use a big capacity; but not having a big capacity in the building I introduced an inductance coil to tune the system down to the frequency of the dynamo, so that from the ground connection this circuit, including the dynamo, the coil, and this

antenna, would have the natural period of the dynamo. Next I recognized the necessity of introducing a means of adjusting, and it is this [shown in Diag. 3 of Fig. 5].

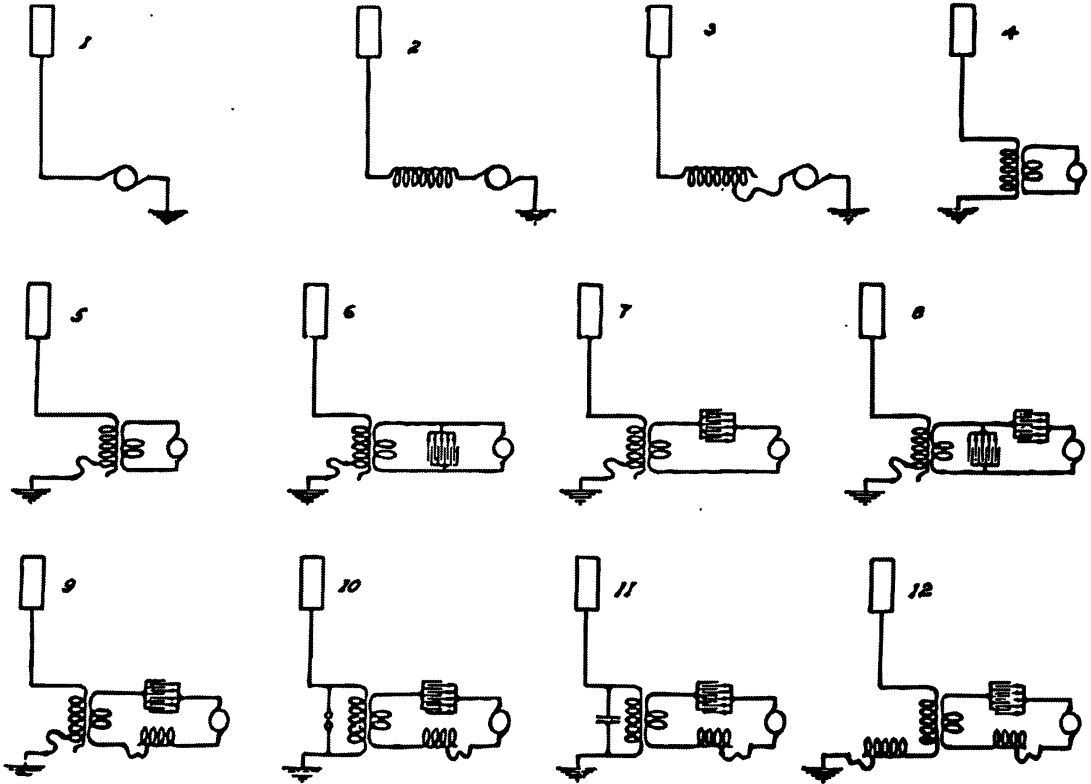

Figure 5.

Illustrating various ways of using a high frequency alternator in the first experiments at the Grand Street Laboratory: 1891-1893.

Now, I found that notwithstanding I tuned this system successfully, I could not get this antenna or these "cans," as we called them at that time, charged sufficiently high. But it occurred to me that if I transformed the current and raised the tension of the dynamo in a transformer, I could then charge the antenna to a higher potential and produce a greater displacement of electricity. That resulted in an arrangement like this [Diag. 4 of Fig. 5], in which I have the dynamo supply a primary coil, generate a second current of higher potential, and tune the secondary and adjust the conditions so that this conductor [connecting the antenna to the transformer], including the secondary of the coil, is again tuned to the frequency of the dynamo. That was a fine advance; it is the one step that today is absolutely essential, because only in the fewest instances can the power of a generator be taken up without transformation.

Then, of course, I introduced for convenience the improvement [an adjustable coil, shown in Diag. 5, Fig. 5]. That was the fifth step.

In order to increase the current in the primary, I adopted an auxiliary condenser circuit [shown in Diag. 6, Fig. 5]. This auxiliary circuit I have, by the way, already illustrated in a patent which was granted to me in 1891 [U.S. Pat. No. 454,622]. The condenser has the effect of magnifying very much the current, this magnification being proportionate to the ratio of the inductance to the resistance of the circuit, and that ratio was very great so I got a strong current which enabled me to greatly magnify the current in the antenna.

In the next step [Diag. 7, Fig. 5], I have again modified something, but it was not drawn up right.[*] I put a condenser in series with the primary. That is exactly the way I operated at Columbia College. At Columbia College I had an adjustable condenser, purchased from W. Marshall, with very small divisions, which I used in series with an inductance coil, and the secondary I was then operating exhibited all the phenomena which have been described in the lecture.

In [Diag. 8, Fig. 5] I show another modification which has certain virtues. I introduced adjustable condensers here, with which I could, first, counteract the self-inductance of the dynamo in one circuit, then raise the tension in the resonant primary circuit, and then tune the secondary of the system to the same vibration.

In [Diag. 9, Fig. 5], as you see, I came to this arrangement where I have an adjustable inductance and adjustable condenser in the primary, and an adjustable coil in the secondary or antenna circuit. That is now a perfectly common arrangement, and it is very convenient and practical.

In the meantime, as I was developing all this, I had already struck a new line of effort toward producing vibrations; namely, I had developed a system permitting me to take the ordinary current of any main and transform it into any kind of vibrations I desired, either damped or undamped. I will dwell on this [later], but I want to say now that I also operated an arrangement as shown here [Diag. 10, Fig. 5]. I bridged the secondary with an air gap. This I did in studying harmonics. I found that sometimes I could get a very strong harmonic, particularly, for instance, the third harmonic was often very strong. By this arrangement I could work with the fundamental tone and with a harmonic, and I made some interesting observations which later on led me to very important inventions.

* Editorial note: Tesla refers to an adjustable primary inductance rather than an adjustable secondary inductance as shown.

[Diag. 11, Fig. 5] is a similar disposition in which I introduced an adjustable condenser, and had the same arrangement in the primary.

And finally, [Diag. 12, Fig. 5] is one of the most common plans which I have been using later in other laboratories -- an adjustable inductance in the antenna circuit, and an adjustable condenser and adjustable inductance in the primary circuit.

Counsel

Will you describe, Mr. Tesla, just how far these went into use, and how far they were shown and exhibited to others?

Tesla

At the time I operated in [my laboratory on] Grand Street, I had in my employ the following men: Mr. Anthony Szigety, a practical Hungarian electrician and wire man who had been a long time employed in France and came over in 1884 or 1885, I do not recall now. Then there was Mr. F.W. Clark, a very skilled mechanic, formerly in the employ of Brown & Sharpe. Besides these were Mr. Charles Leonhardt, a young Hungarian mechanic, and Mr. Paul Noyes, a former employee of the Gordon Press Works of Rahway where I engaged him while I was developing my arc light system, which was adopted by the city at that time. There was also a man by the name of David Hiergesell, a German-American glass blower.

At the time I made these experiments, there were very few of the electricians, that since made a success with wireless in some way or another, who would have known much about these things anyway. They had seen me run the wire up the building, they had seen me operate continuously with those machines. I had shown them wonderful results, and had told them all the time that I was going to transmit energy without wire -- telephone, telegraph, run cars and lights at any distance -- and that these were the primary steps toward this end. How much these men could tell, in the light of the present knowledge, that, of course, I am unable to say; but, certainly, I had plenty of witnesses to follow my work, and to know what I had been doing.

This second machine [Fig. 6] I was building while I was carrying on experiments with the first machine. As you will note, I had stripped all the wire from the armature. I had taken the finest steel I could get and constructed a machine with opposite poles, with what we call a "stiff" field, and had done away with all moving wire. I intended to connect a turbine and run this machine at a very high speed, which I thought might be up to 20,000 revolutions. The armature conductors were disposed in this field, and the coil that was

(No Model.)

2 Sheets—Sheet 1.

N. TESLA.

ALTERNATING ELECTRIC CURRENT GENERATOR.

No. 447,921.

Patented Mar. 10, 1891.

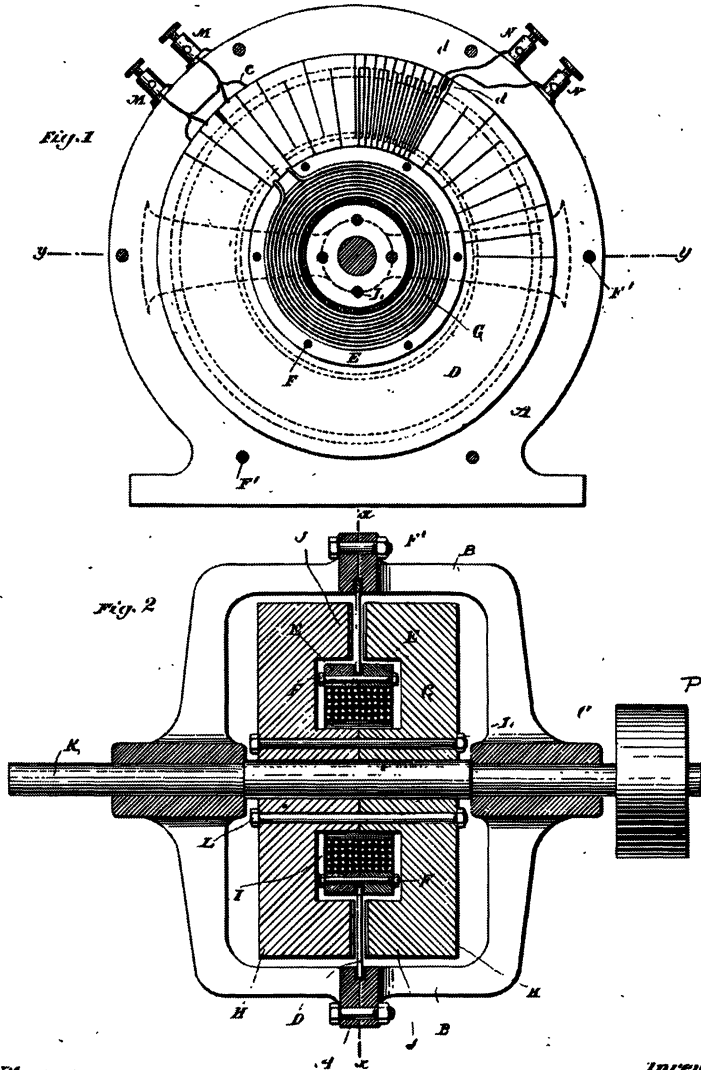

Witnesses:
Ernest Hopkinson
Frank B. Murphy,

Inventor
Nikola Tesla
 by
Duncan & Page
 Attorneys.

Figure 6.
 Diagrammatic illustration of the second machine built with no wire on the rotating part, designed for turbine drive, taken from U.S. Patent No. 447,921 of March 10, 1891. Application filed November 15, 1890.

exciting the magnet was supported by the conductors, and, as seen in this drawing, I had two wires for the field and two wires for the conductors. Usually, however, I had six binding posts because I had two circuits displaced by quarter-phase in the armature.

I have spent years and years in designing machines, and I have never yet built one machine but that the people who saw it complimented me on its compactness and the thoroughness of my design. These men were students; they did not know how to do it. They made a machine which had an internal resistance of 6 ohms and expected to raise the tension one hundred fold. Why, the resistance of my machine was 1/40 of an ohm only! They wanted to make a short conductor and made a conductor many feet long. The wire in my machine was but 4 feet long. So, you see, I had embodied in this machine the finest thoughts of design. It could not be improved any more because I had gone to the limit of everything; limit of tensile strength, limit of air space, limit of copper, limit of every other material. This machine I have used for many years with great success, and I have discovered many, many facts in connection with wireless by its means, and some of these facts I will tell you.

Counsel

What has happened to that machine?

Tesla

I used it for years and years; used it until recently. That machine must still be in existence, but with the only difference that I have reduced the number of poles. It was to do away with the spark gap. That was an idea that I conceived sometime in 1892, but it dragged on until a later period. My idea was to construct a machine with a certain small number of poles, rotate it at an enormous speed, and thus generate sudden impulses which would produce the same effect as the arc discharge in my so-called "Tesla transformer." Originally, this machine had 64 poles. Then [in 1901] I reduced them to 32, and finally to 16, and in that form I have produced with it any oscillations, continuous trains or undamped oscillations of any frequency I desired. That is done by a process not yet well known, except only so far that electricians have produced higher harmonics from low fundamentals; but in that case they have obtained a very small energy. Now, I have perfected a scheme enabling me to take, for instance, this machine, which will give me 3,000 or 4,000 oscillations, and from these oscillations develop 100,000 [oscillations], and there will be a continuous train of undamped waves.

Counsel

During what years was this machine used?

Tesla

This machine was built in 1891. I used it continuously, certainly, until 1905 or 1906.

Counsel

When was it you reduced the number of poles?

Tesla

I reduced the number of poles, I think, in 1901. But then I reduced it for the purpose of generating currents of higher frequency. If I had a great number of poles, I could not realize my idea, because these poles would come in quick succession and not produce a rate of change comparable to the rate of change which is obtainable by the discharge of a condenser owing to a sudden break of the dielectric. That is to say, a blow. It has to be a blow, you see. I had to place my poles comparatively far apart, then run them at excessive speed and generate comparatively few impulses, but each of those impulses are of such tremendous intensity that the dynamo is practically short-circuited. That gave me a blow which replaced the arc. And then, of course, there remained to be perfected a scheme enabling me to get the energy of the alternator in the most economical manner, in high harmonics. That is not known, at least I have not seen anything of that kind in literature, and I believe that if anybody would attempt it without the devices which I have invented, he could not get much of the energy in high harmonics.

Counsel

What was the output of that machine in its original form?

Tesla

The output of the machine was about 8 kilowatts; but, observe, I did not [then] have the turbine [patented in 1913]. If I had had the turbine, I could have run this machine [at] 20,000 revolutions, and then I would have had a [significantly higher] output.

[The machine] had a stationary armature and no wire. It was of the finest steel, all stationary, and the current was taken from stationary terminals. [It] is the final type which, after all these years, other electricians have come to.

Counsel

How fast did you run that before you reduced the number of poles?

Tesla

Up to 12,000 [revolutions]. I used this machine in transmission of signals, particularly with the telephone, in a great many investigations, and I discovered a way, for instance, of measuring accurately capacities employing this machine. You know that, normally, the capacity of an antenna cannot be measured very closely. The ablest men [in the art] -- Prof. Ze-neck and Prof. Stone -- know how it is. But, with the scheme I have developed, I could measure any capacity. With an antenna of 1,000 centimeters, I can very easily read half a centimeter.[*] There is no method known which would

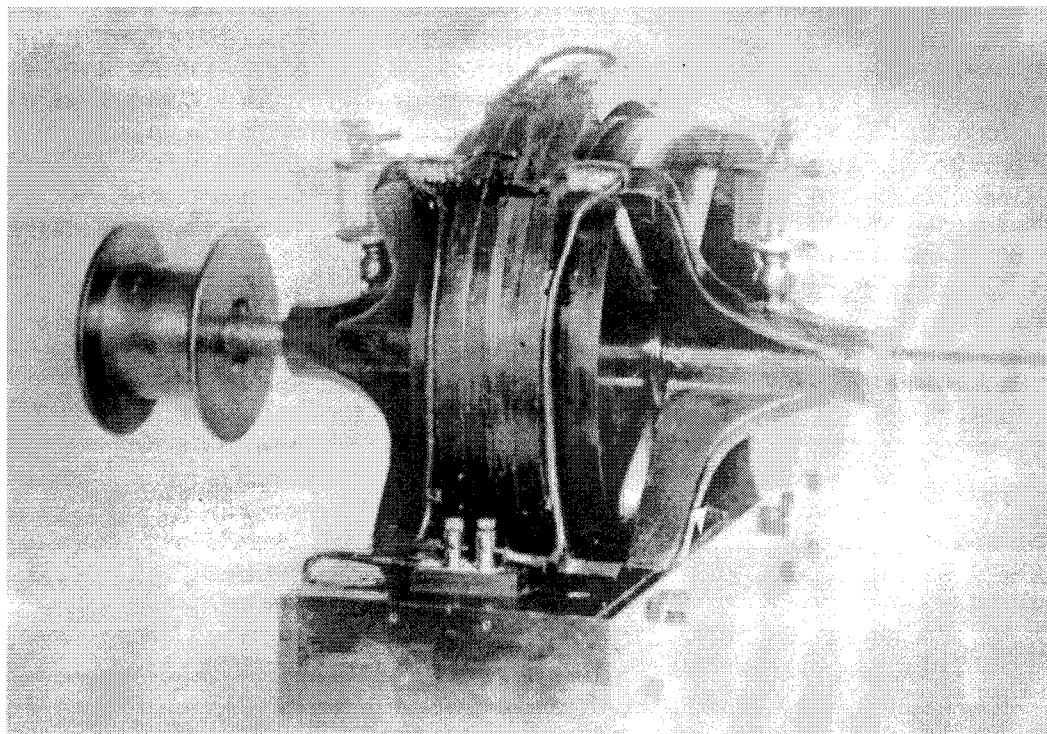

Figure 7.

Photograph of machine covered by U.S. Patent No. 447,921 of March 10, 1891. Application filed November 15, 1890.

* Editorial note: Capacitance values expressed in centimeters are in electrostatic units; to convert from centimeters to picofarads, multiply by $10/9$. Thus, in the situation described, with an antenna of 0.0011 microfarad, Tesla could read an increment of 0.55 picofarad.

enable an expert to read as closely as that. I used this machine in experiments as these. It was a very fine piece of apparatus for all sorts of wireless demonstrations.

In those years, of course, I was developing the principles. I have shown that five steps had to be accomplished before wireless was an art, a real art that could be applied scientifically.

[Fig. 7] shows this machine as it actually was. You notice here a wire [pointing to the top] -- a solid, thick wire. In the form that you see the machine here, I used it for developing harmonics, and in this case I had a condenser soldered to the alternator so that I would get a system of no resistance, practically. The resistance in my alternator was only 1/40 of an ohm. I made a primary -- that is not seen here -- the resistance of which was also negligible. I combined it with the condenser and tuned it so that I got a current of tremendous volume in that circuit, and then I operated it with the secondary.

[Fig. 8 shows] another machine. This is the third machine which I built, a larger one. This machine is described by me in the U.S. Patent No. 447,921 of March 10, 1891. It was constructed early in 1891.

Then I made a change. On my return from England [in 1892], I took it apart and completed it again in a little changed condition in my next laboratory at 35 South Fifth Avenue. In this machine, I had the same kind of field -- what we call a "stiff" field -- and in that I arranged a disc to rotate, which was cut out in a proper way so as to give me a zig-zag conductor. I wanted to have a very light rotor, and thought that this form, rotating, keeping the conductors in [a] plane by centrifugal force, would be a very good one to experiment with. The machine was of very much larger capacity; it was built with 480 poles, and I could get from it, at comparatively low speed, 30,000 cycles per second. I could get, in fact, more. This machine was also destroyed by fire. Of these three machines which I have shown you, only the second one was saved from my laboratory fire in May 1895. [*]

* Editorial note: Fig. 7 is from a photograph taken after the laboratory fire. Another machine, which had been on loan to the Westinghouse Electric & Manufacturing Company, also escaped the laboratory fire. See Appendix I, Fig. A1-1, for a 1938 photograph.

(No Model.)

2 Sheets—Sheet 2.

N. TESLA.

ALTERNATING ELECTRIC CURRENT GENERATOR.

No. 447,921.

Patented Mar. 10, 1891.

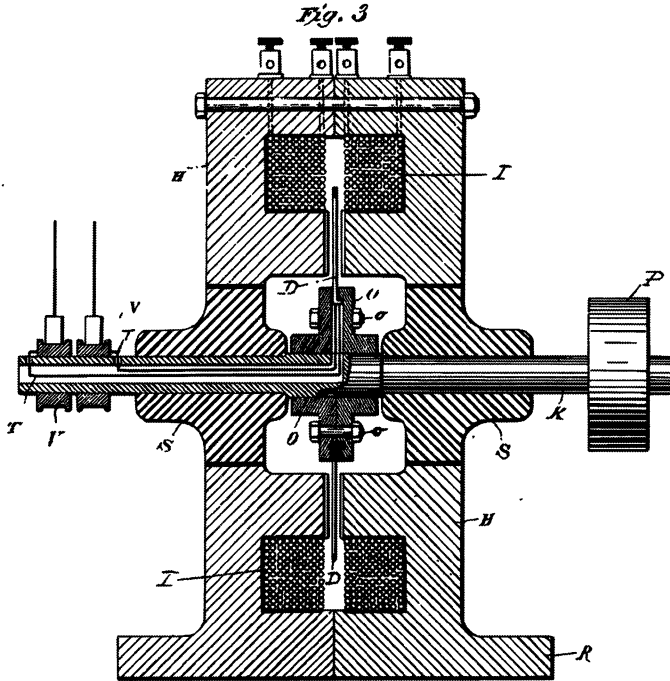
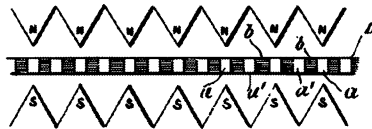

Fig. 4



Witnesses:
Ernest S. Johnson
Frank B. Murphy.

Inventor
Nikola Tesla
Duncan & Page
 Attorneys.

Figure 8.
 Diagrammatic drawing of the third and larger machine with 480 poles, taken from U.S. Patent No. 447,921.

Figure 9.
Photographic view of
alternator covered by
U.S. Patent No. 447,921.
Illustrated in Martin
book, Fig. 98, p. 154.

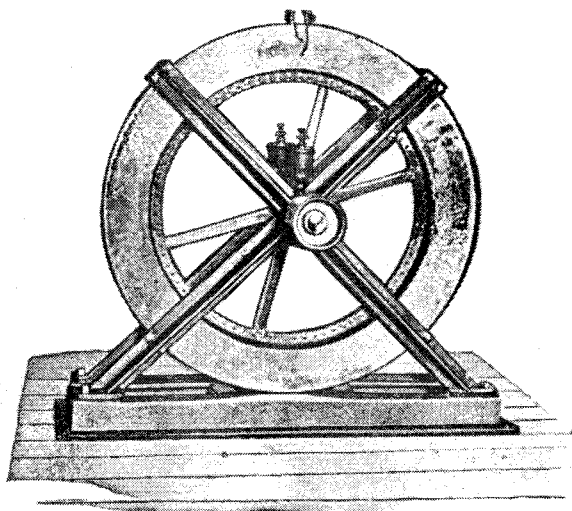

FIG. 98.

[Fig. 9] is a photographic representation of the machine, but it is not so apparent that it was a machine of much larger capacity. I could get out of it readily 25 kilowatts.

Those are not the only machines I built. I constructed quite a number of other high frequency machines. Some of these were obviously small, and I built them chiefly for scientific investigations and for use in connection with receiving circuits.

One of my ideas was to generate at the receiving station oscillations of a certain frequency, and then combine them with an incoming oscillation to obtain beats. And later on, in 1898, I worked this idea into an invention which has been called a "telautomaton," and which has begun to be appreciated because Congress voted a certain expenditure of money, \$750,000, for that machine which I vainly attempted to persuade them to accept.[*] I perfected the machine in 1898, and tried everything in my power to have it adopted; but, everybody was ridiculing my efforts. Everybody said it is impracticable, and after my patent expired only a few months ago, Congress appropriated this sum and I have now the pleasure of simply looking on when others are using my inventions, which I could not persuade people to adopt. This is usually so.

[Fig. 10] shows a type of small alternator, one of two forms which I will show you, that from the constructive point of view, is rather poor. I will admit that. But, it was

* Editorial note: For further remarks on attempts to persuade the U.S. Navy Department to fund the idea, see p. 158.

convenient for me to construct it that way. You see, the magnetic circuit is constituted by the laminated core here, [and] there is an exciting coil. In this picture you will also note the field wires, and the rotor is indicated. With this machine I could get 200,000 cycles per second, [*] very readily, but the output was very small. It was used mostly for telephonic work and for scientific investigations.

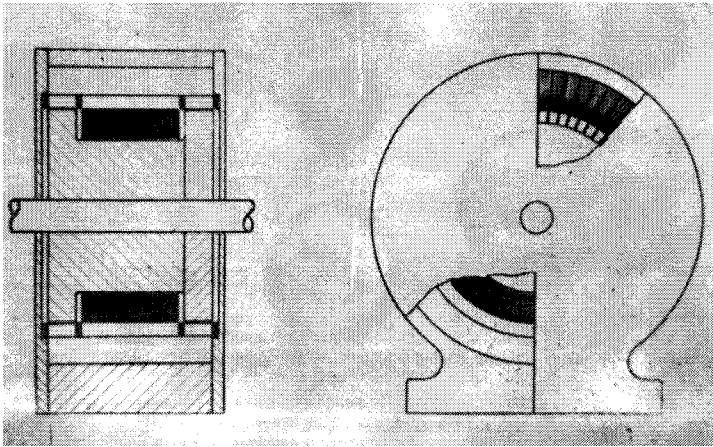

Figure 10.

Small alternator of very high frequency built for purposes of investigation, chiefly in conjunction with receivers. Drawing. Measurement purposes.

This [Fig. 11], if you please, is another small machine which I built, and with it I also obtained a very high number of cycles. You see how that was made. Here [field] I have 8 laminated magnets, and the circuit was formed through here, you see. On the rotating part I had 9 projections so that if,

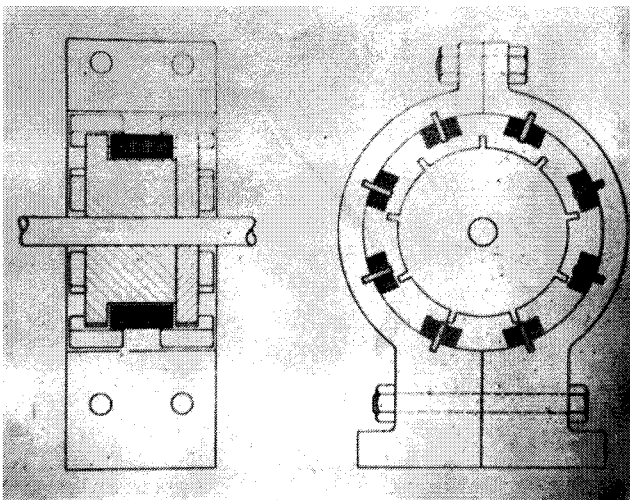

Figure 11.

Another small high-frequency alternator of different construction intended for the same purposes. Drawing. Mercury interrupters, 1898.

* Editorial note: This was accomplished by having the number of field magnets differing from the number of armature projections by one. For the general case, the number of field magnets and armature projections must have an even-odd relation.

for instance, this armature was rotated, say, in the clockwise direction, then the magnets will come successively into play also in the clockwise direction.[*] But, as you will readily note, I had a very small electromotive force, for the reason that there was always the inductance of seven coils while one was generating the electromotive force. However, [the] inductance I could overcome by resonance, in properly adjusting the capacity, so that was no objection, and the machine was extremely serviceable. This machine gives, by one revolution, 72 impulses -- 72 cycles, because there are 8 poles and 9 projections. That means $8 \times 9 = 72$. And, of course, being small, light, and balanced, I could rotate it a very great speed and get a very high frequency.

Counsel

In what patent was that shown?

Tesla

This idea was disclosed in my patents on mercury interrupters which were published in 1898. You will find the same idea in my mercury interrupters. I used 7 streams of mercury, and 8 projections. In fact, in one I have constructed, I used 25 projections and 24 streams, and I could get a very high frequency which is unobtainable with a very high frequency dynamo.

The machines which I have described so far were all of the ordinary type; that is, insofar as the mode of field excitation was concerned.

[Fig. 12] shows another type of machine which was patented by me before I had conceived the principle of exciting a machine, not by direct current, but by current of different phase producing a whirling magnetic field, and then rotating in that field an armature and generating currents in the same. This type has been taken up later by a very able German engineer, Mr. Goldschmidt, and today it is known as the Goldschmidt machine. Of course, nobody mentions me at all, and I suppose everything is fair in wireless as in love and war. But, I gave the idea of these machines, and I had several of them with which I experimented continuously.

There is this to be said [about this type of machine]. When you rotate the armature in the direction of the rotating poles, but with a higher velocity, then it is a machine which has got the field excited by a simple alternating current;

* Editorial note: For the case where the number of field magnets is 8 and the number of armature projections is 7, resulting in 56 impulses per revolution, and the armature is rotated in the clockwise direction, the field magnets will come successively into play in the counter-clockwise direction.

(No Model.)

N. TESLA.

DYNAMO ELECTRIC MACHINE.

No. 390,721.

Patented Oct. 9, 1888.

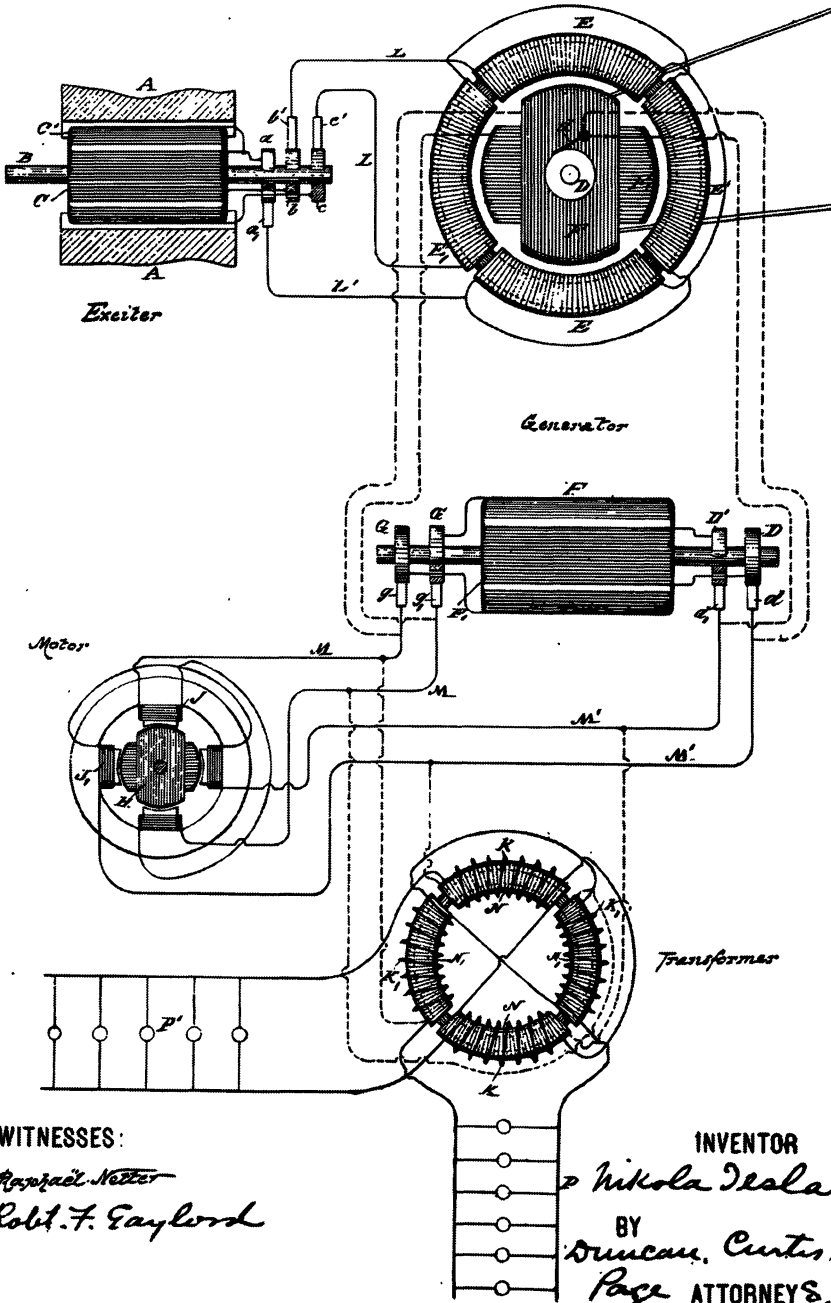

WITNESSES:
Raphael Nestor
Robt. F. Gaylord

INVENTOR
Nikola Tesla
 BY
Duncan, Curtis & Page ATTORNEYS.

Figure 12.
 Diagrammatic illustration of another type of machine with rotating magnetic field excitation, as described in U.S. Patent No. 390,721 of October 9, 1888. Application filed April 28, 1888.

when you rotate it in the other direction, then the rotating field really comes in, and you obtain a higher frequency. If you rotate the field just as fast one way as the armature is rotated the other way, you have then, for example, twice the frequency.

The objection to this machine I found to lie in the fact that the current is not strictly sinusoidal. You see, when the flux in the field varies harmonically, then there are two inductions; one is the induction due to the motion of the wire across the field and the other is the induction comparable to that taking place in a static transformer. This latter is proportional to the sine, the other is proportional to the square of the sine, and the result is that we get a little distorted curve. Nevertheless, the principle is applicable, and [it] has been applied by Goldschmidt in a commercial machine.

Now I am coming to a very wonderful discovery which I made in connection with high frequency alternators, and I do not believe that there is a man in the technical profession today who dreams about it; not one. This discovery proved to me that, without further provision, it was impossible to use a high frequency alternator in wireless work that required any kind of fineness; and I made this discovery in the following way. I was operating with three high frequency alternators in my laboratory at 35 South Fifth Avenue. I would run [any] one of the machines, tune a circuit, then go around the city and get the hum of the alternator in my tuned receiving circuit, and from this note and the intensity of the sound I could judge the quality of the devices that I was using. That was a very convenient way; I did it continuously. I operated mostly between the laboratory on South Fifth Avenue and the Hotel Gerlach on 27th Street, near Sixth Avenue, where I was stop-ping.

While I was carrying on this work I was perfecting methods and apparatus for attunement, and I noticed that gradually I could not get as good results as I got before. I could not understand this. But after a few days of investigation, one day it happened that I was trying to get a note on the top of the Gerlach and could not get the hum of the alternator. I was giving it up, when all of a sudden out it rang very sharp and clear, and was off again suddenly, as though a wire had been broken. I said to myself, a wire has been broken somewhere in the circuit and went down to the laboratory where I examined all carefully. But everything was in order. Then the idea flashed upon me that my receiving circuit was sharply attuned, and the alternator was giving not one but many frequencies; the alternator was all the time changing speed, like every alternator does. It does not give one frequency, it gives many frequencies.

Now, I solved that problem in 1898, and I will tell you how I solved it. I said to myself, here is a generator that gives a dozen different frequencies, but very closely related. They follow one another in succession. How am I going to get selectivity, and at the same time have a perfect response? I solved this through what I term the principle of individualization. An ordinary circuit has one characteristic; it responds to a certain note. An individual has more than one characteristic; [he] comprises many in combination. Similarly, I combine several circuits and depend on the cooperation of these circuits to operate my device.

My first step was to tune several circuits very closely together, so closely that they would pick up [any] of the frequencies within the range of the change of the alternator [speed], and I operated with all these circuits on my receiver. The moment I used that kind of a circuit, I found that I got very clearly the note of the alternator because my receiver was responding to any of the frequencies which were produced. On the other hand, when foreign frequencies would come in to disturb, I would only get a partial effect, as my normal effect was due to all the frequencies combined, whereas the outside effect was due to just the one frequency. I presented the same principle in a lecture before the New York Academy of Sciences on April 6, 1897, but which was not published.

There were certain steps to be accomplished, [however,] before the wireless could be on a really practical and scientific basis. The next step to accomplish, after all had been done, was to design an apparatus which will exactly suit the earth; that is, which will give the proper wavelengths suitable for it, and will also be in all other respects adapted to the physical conditions of the globe on which we live, and to the place on which the plant is erected. The earth is not a sphere; it is an oblate spheroid, owing to the effect of centrifugal force. Now, it makes all the difference whether a scientifically correct apparatus is placed in a northern region, near the pole, or near the equator, because the length of the conductor is not the same.

In the account of the experiments and machines which I [have earlier shown], I hope I have proved that those machines represented the farthest advancement in the art, not only of that time but of the present day. Not that I would say I was a better designer -- nothing would be further from my mind. I simply mean that my followers did not require the limitations of frequency, and I have stuck to those designs which were most efficient. Alexanderson said,

"We are compelled to go to the very frequencies that you [i.e., Tesla] used in your earlier demonstrations."

There were reasons why I made machines of low frequency

in my experimental work, why I stuck to these frequencies which I have used in my early lectures and public demonstrations. Firstly, because such a machine can be efficiently built for high output, which a machine for 200,000 cannot. Secondly, the waves which are generated were less absorbed because they are of lower frequency. They went to greater distance; the effects were greater. But there was still a third reason: Whenever I received the effects of a transmitter, one of the most convenient and simplest ways [to detect them] was to apply a magnetic field to currents generated in a conductor, and when I did so, the low frequency gave audible notes.

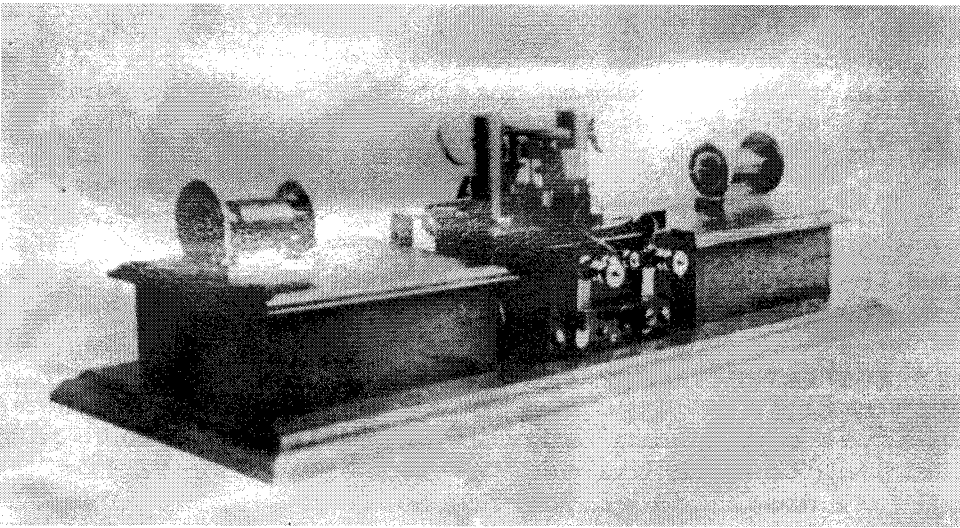

Figure 13.

Instrument to receive radio waves of 1896-1899 structure.

One of the simplest devices I used in my experiments between my laboratory on South Fifth Avenue and [at] the Gerlach Hotel, and other places in and outside the city, was an instrument constructed in 1896 with a magnet which sometimes was so designed as to give me a very intense magnetic field up to 20,000 lines per square centimeter. In this [field] I placed a conductor, a wire or a coil, and then I would get a note which I amplified and intensified in many ways. From the characteristics of the audible note, I would immediately judge the quality of my apparatus.

When I speak of an audible note, I mean a note audible in a telephone as produced by the diaphragm of a telephone, or by a vibrating wire within the range of audibility.

[Fig. 13] shows the general arrangement of [the receiving] apparatus.[*] Two condensers are the boxes at each end,

* Editorial note: Also see discussion in association with Fig. 94, p. 162.

and in the center a coil, or two coils, according to necessity, with which I produced a strong magnetic field and [placed] in it a wire. These condensers and the wire form a circuit which I tune. The condensers are of comparatively large capacity because my conductor is so short. I usually would transform the current in the receiving circuit and make as close a connection as possible and then tune the circuit to the vibrations. I would also mechanically tune the wire, according to the frequency, to the same note or to a fundamental.

This machine was suitable for transportation. I could put it under my arm with a couple of batteries. I had relays, which were very big, in which I produced (for stationary work) a very intense magnetic field so as to affect the conductor by the feeblest current. Furthermore, I used these relays particularly in connection with beats. When the frequencies were very high, I combined two frequencies very nearly alike. That gave me a low beat. One of the frequencies I sometimes produced at the receiving station, and at other times at both the receiving and transmitting stations. This always gave me the means of producing an audible note. I used machines of this character from 1892, but this specific instrument in my laboratory on Houston Street.

This instrument comprising a magnet and chord or coil in the magnetic field -- I mean a wire or coil in the magnetic field -- is an old academic device, used in all sorts of demonstrations at the schools and the university where I was studying. My professor of physics has had similar instruments with an adjustable spring and magnet, and I have employed them in assisting him. There is nothing novel in the idea. The only novelty was that I kept my alternation low and I made this arrangement with conductors to tune.

It was very convenient for producing audible effects because, if I used other forms of a receiver, I had a reading which was not at once translatabe. If I listened to a note, I could immediately tell the quality of the transmission. For instance, I would tune a circuit in my laboratory, take it out to another building, and I would receive the signals; and from the quality of the signals I would see how I was progressing.

Counsel

In the experiments that you have spoken of with the instrument of which the picture is shown [as Fig. 13], what were the distances between the transmitting and receiving stations?

Tesla

The distance at that time, and I think the greatest distance at which I ever received signals from the Houston Street

laboratory, was from the Houston laboratory to West Point. That is, I think, a distance of about 30 miles. This was prior to 1897 when Lord Kelvin came to my laboratory. In 1898 I made certain demonstrations before the Examiner-in-Chief of the Patent Office, Mr. Seeley, and it was upon showing him the practicability of the transmission that patents were granted to me.

Counsel

At that experiment were you at the Houston Street end or at the West Point end?

Tesla

In that experiment I produced continuous trains of oscillations and went with the instrument to West Point. I did this two or three times. There were no signals actually given. I simply got the note, but that was for me just the same.

Counsel

That is to say, you did not make and break the circuit?

Tesla

No, and I did not receive any signals, but I did receive the audible notes in my telephone receiver.

Counsel

At West Point?

Tesla

Yes, in or about the year 1897.

Counsel

And did the continuous transmission thus received start from Houston Street?

Tesla

Yes.

Counsel

Was one of your employees there?

Tesla

Yes, the employees knew that I was running the apparatus.

On frequent occasions, I would get a boy to make and break the circuit. Then I found it was much simpler to just let the apparatus run and get the notes.

Counsel

What was the distance between transmission and reception?

Tesla

That was the distance from my laboratory on Houston Street to the Gerlach Hotel.

Counsel

Is this instrument [Fig. 13] the same general type which is colloquially known as a string galvanometer?

Tesla

No, it is not. Such a scientific instrument is used in the schools, for instance, in various kinds of demonstrations.

Counsel

In [Fig. 13], is that [wire] shown on the apparatus in series in the circuit, and is it in the field of the magnet?

Tesla

Yes. I had a coil, or a straight wire, in the field -- it made no difference. It was the reaction of the currents on the field that produced the audible note.

Counsel

What is the furthest distance from your source of transmission that you used the apparatus of this character?

Tesla

I think that I used this once at the Western Union Building -- on the roof -- in company with Mr. Alfred K. Brown. That would be a distance of probably 2 miles.

Counsel

What was the character of the reception?

Tesla

Just the alternator was run and you could hear the note of the same when the circuit and the string was tuned to

the same frequency.

Counsel

Did you hear it?

Tesla

You could hear it all over the place.

Counsel

You mean you did not have to have your ear in the telephone to hear it?

Tesla

No, not at all; I could hear it from a distance. The vibrations were very vigorous.

Counsel

About when was that?

Tesla

That must have been either late 1896 or early in 1897.

Counsel

What was the frequency of alternation that you were using?

Tesla

The frequency might have been something like -- I should say -- in the neighborhood of 5,000.

Counsel

Was there anything hidden about these uses, or were they open so that anyone could use them?

Tesla

There were thousands of people, distinguished men of all kinds, from kings and greatest artists and scientists in the world, down to some old chums of mine -- mechanics, to whom my laboratory was always open. I showed it to everybody; I talked freely about it.

(No Model.)

N. TESLA.
ELECTRICAL CONDENSER.

No. 464,667.

Patented Dec. 8, 1891.

Fig. 1

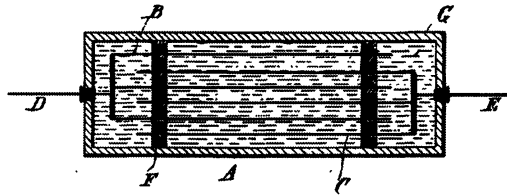
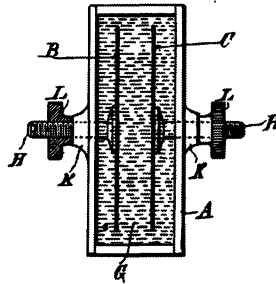

Fig. 2



Witnesses:

Raphael Netto
Frank B. Murphy,

Inventor

Nikola Tesla
by
Duncan & Page
Attorney

(No Model.)

N. TESLA.
ELECTRICAL CONDENSER.

No. 567,818.

Patented Sept. 15, 1896.

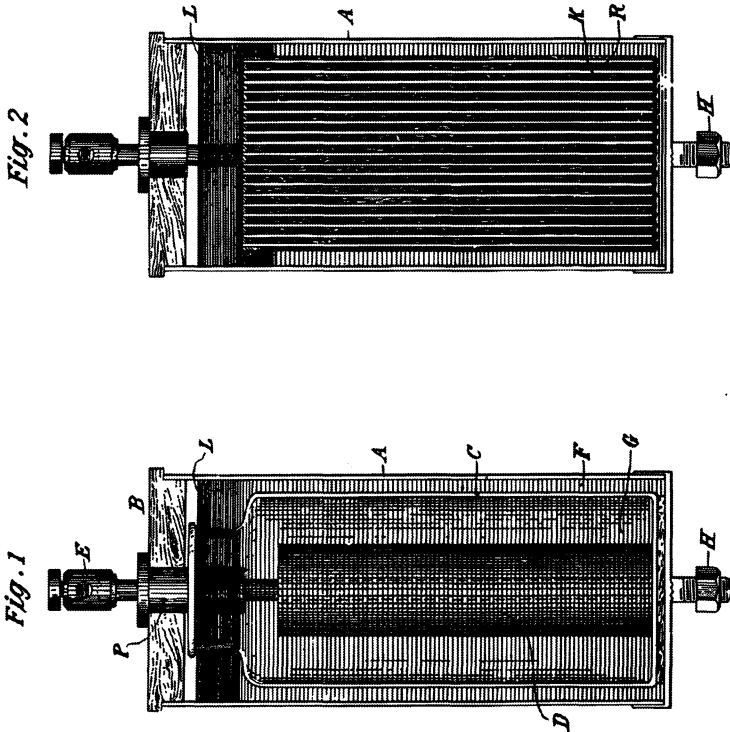

WITNESSES
Raphael Netto
Dwight W. Cooper

INVENTOR
Nikola Tesla
 BY
Herr. Curtis & Page
 ATTORNEYS

Figure 15.

Forms described in U.S. Patent No. 567,818 of September 15, 1896.
Application filed June 17, 1896.

Counsel

When you said, "5,000," did you mean cycles or alternations?

Tesla

I mean cycles. On another occasion I have also operated -- going a little further into showing the reactions of high frequency currents upon magnetic fields -- I have operated motors, and at that time I have stated what frequencies had to be used in order to produce these rotations, which are, of course, due to reactions of the currents on the field. I have pointed out, in the Martin book, that they should be from 5,000 to 10,000.

I would like to proceed, without going into details making this too hard to follow. I would like to have this simply a clean story with only the salient facts pointed out, and not a maze of little details which would complicate it and spoil the harmony. Proceeding, then,

[Fig. 14] shows a form of condenser in which I have boiled out all the air bubbles, and the next drawing [Fig. 15] shows another form.

I have made a notable advance in this condenser, with which I have operated in my laboratory on Houston Street and in experiments at my wireless station in Colorado. This is the most efficient form of condenser known, showing practically no loss whatever. And it is only with this condenser that really very fine results are obtainable because, even if we employ mica condensers immersed in oil, or glass of the best kind coated with tinfoil, we do not get the results which we get with this condenser, and they are obtained by substituting electrolyte for the metallic coatings as before. I used electrolytes which were especially adapted for that, and cheap -- for instance, like a solution of ordinary salt. It is cheap and readily obtainable.

[Fig. 16] shows a type of this kind of condenser in finished form as I used them in my laboratories. There were many of these adapted to be secured on the bottom. They were readily transportable. Occasionally, I took some of these condensers with me when I experimented.

[Fig. 17] shows another improved form of condenser. I do not have a photograph of a finished apparatus and this is a sketch that was made in 1896 shortly before a condenser of this kind was constructed. That was a condenser intended for high electric pressure and the insulation was obtained through the air. It was built for 500 atmospheres air pressure safely. There is a reference in my writings where I point out

the use of compressed air, and therefore there was no creative effort involved in any patent in that direction by Fessenden and others.

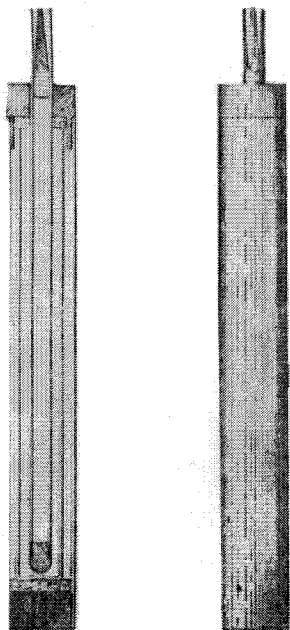

Figure 16.
Improved form of electrolyte condenser as used in laboratories on 35 S. Fifth Avenue and 46 E. Houston Street.

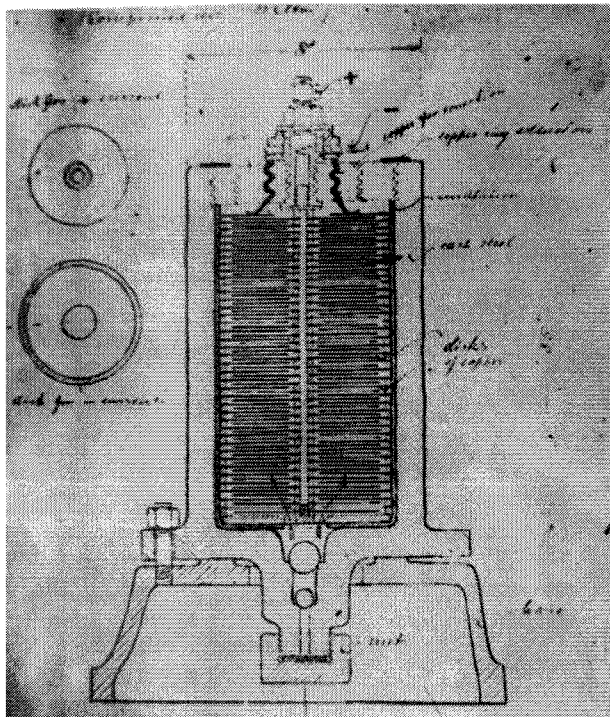

Figure 17.
Form of condenser with air under great pressure as dielectric used at the same period, subsequently patented by others.

The apparatus shown by the drawing [Fig. 18] which I designed and installed was for years employed to practice this process of manufacture. This process is [now] universally adopted; everybody uses it. There are millions and millions involved in it. If I could only get one cent for every apparatus that is manufactured in accordance with my invention, I could erect a building like the Woolworth and not feel the expense.[*] Everybody uses it, but nobody says thanks. That was arranged for what was called a vacuum pressure process.

* Editorial note: At the time of this interview, Tesla had shortly before removed his offices from the Woolworth Building where they had been established for one year.

(No Model.)

N. TESLA.

MANUFACTURE OF ELECTRICAL CONDENSERS, COILS, &c.

No. 577,671.

Patented Feb. 23, 1897.

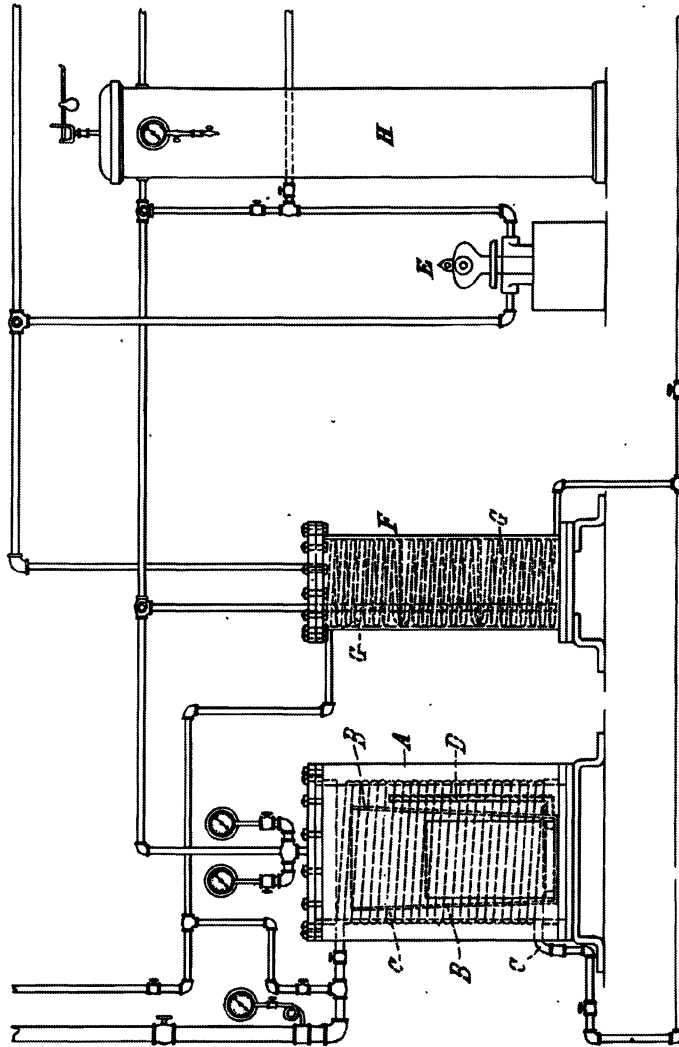

WITNESSES

Edwin B. Stephenson,
Benjamin Miller,

INVENTOR

Nikola Tesla

BY

Ken. Curtis Page

ATTORNEYS.

Figure 18.

Apparatus for manufacture of condensers and coils to exclude air as described in U.S. Patent No. 577,671 of February 23, 1897. Application filed November 5, 1896. The whole manufacture is now dependent on this or similar processes, and many patents have been secured by others.

Steinmetz says,

"No, I have found a better way. I just put the thing in kerosene."

It is thin and penetrates in the inside and, of course, he gets a patent.

I am [next] coming to a chapter in my life which was very fruitful. I was absorbed in the development of a new type of generator. The solution, which enables me to use the high frequency alternator practically, was not yet found at that time. I saw that the high frequency alternator was not usable for any finer work. We were driving toward perfection and that if we attained it, the alternator would be simply thrown away as an absolutely useless instrument. That was my conviction, and I attempted to attain the results which I subsequently reached with the alternator in another way. To this end I built a great many machines of a novel type, which I called oscillators -- mechanical and electrical oscillators -- and it is with these that my best results in the investigations of these phenomena, applicable to wireless in many of its phases, were obtained.

III. Mechanical and Electrical Oscillators

Tesla

The photograph [Fig. 19] shows my earliest experimental oscillator which I used to generate electrical vibrations.

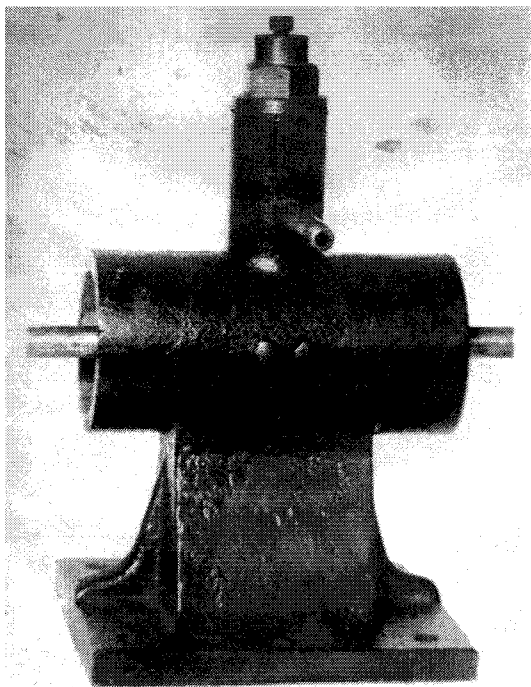

Figure 19.
**Simple mechanical oscillator
used in first experiments.**

My first efforts were to produce this vibratory mechanical motion, then attach to this system an electrical generator; that is, I would attach a conductor to it and vibrate it in a magnetic field. That was the first step in the evolution of the idea. The machine is shown here without any attachment.

The drawing [Fig. 20] illustrates the next advance in the evolution of the idea. I have produced isochronous oscillation, and now I am applying considerable power to the piston to develop energy in this electric system. It is the energy of the mechanical system which produces the electrical energy in the circuit, but the vibration is controlled by the tremendous force of the air spring against which the small impressed force is nothing. In this manner, then, I first obtained isochronous electrical oscillations, which no transmitter made today furnishes except my own.

The drawing [Fig. 21] illustrates the next improvement. I conceived the idea, instead of using a mechanical air spring

(No Model.)

2 Sheets—Sheet 1.

N. TESLA.
ELECTRIC GENERATOR.

No. 511,916.

Patented Jan. 2, 1894.

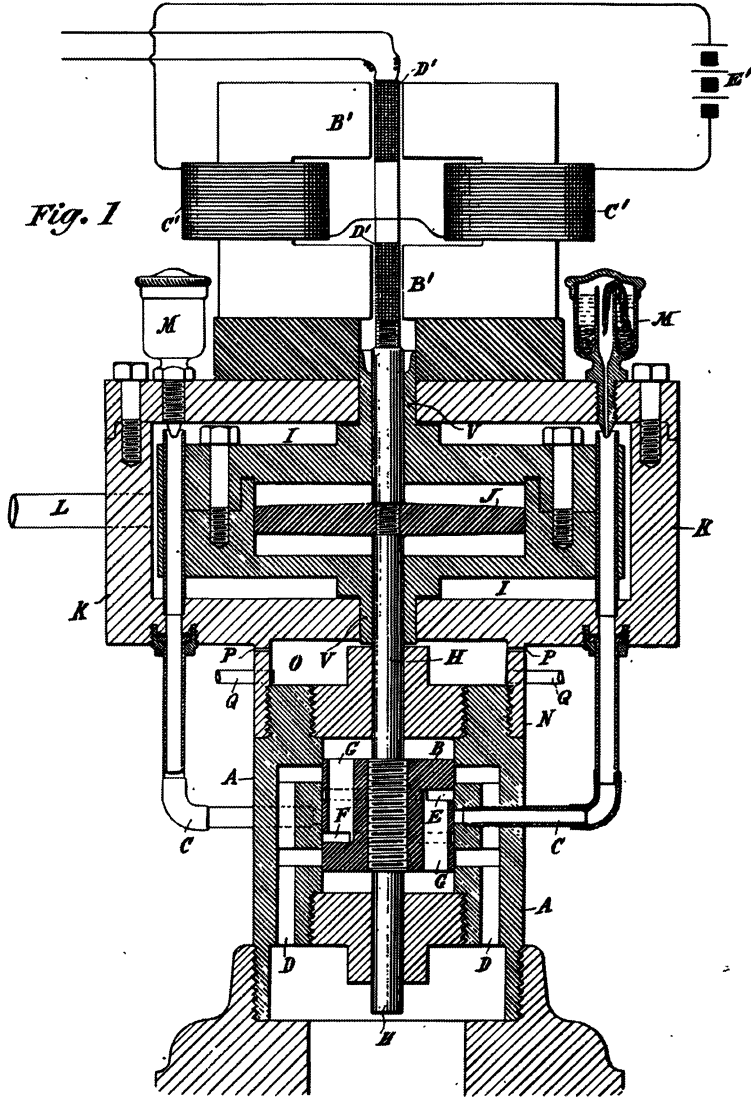

Witnesses
Raphael Neter
R. F. Gaylord

Inventor
Nikola Tesla
 By his Attorneys
Duncan & Page

Figure 20.
 Mechanical oscillator with air spring combined with electric generator as shown in U.S. Patent No. 511,916 of January 2, 1894. Application filed August 19, 1893.

(No Model.)

2 Sheets—Sheet 2.

N. TESLA.
ELECTRIC GENERATOR.

No. 511,916.

Patented Jan. 2, 1894.

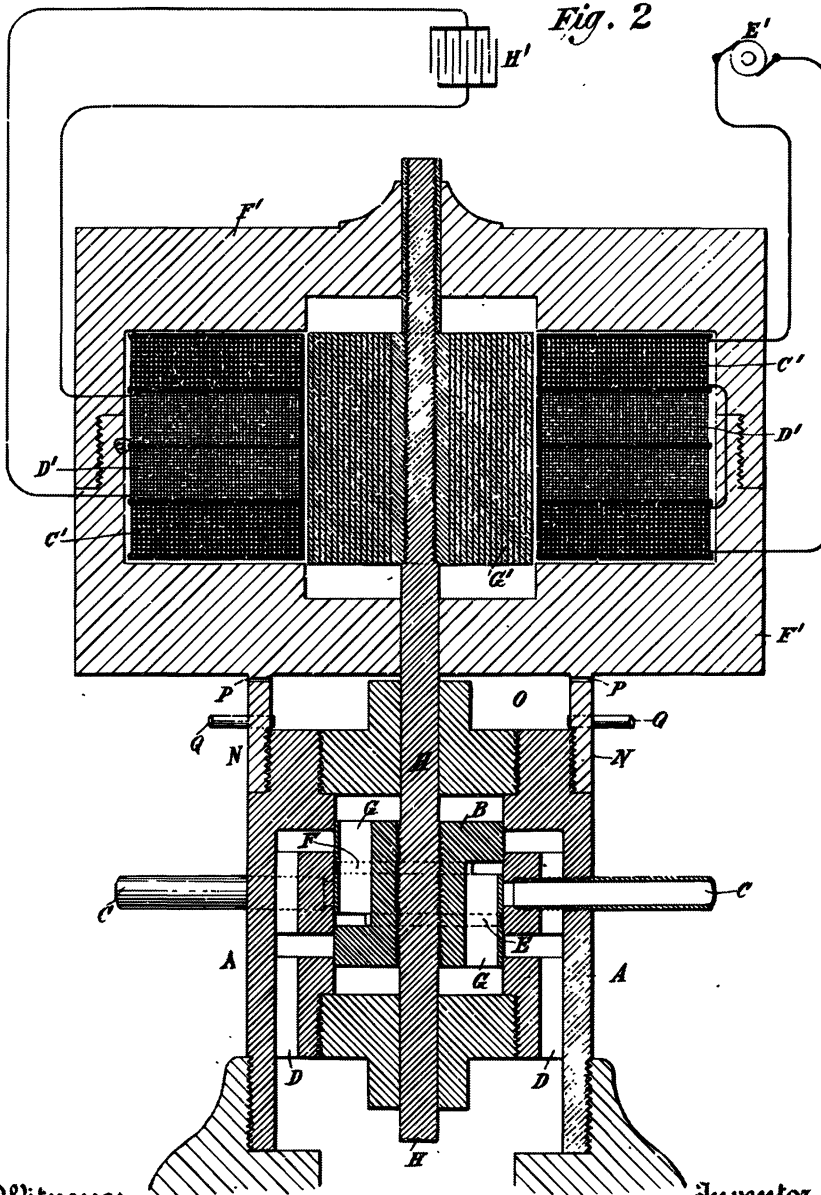

Witnesses
Raphael Netter
R. F. Gaylord

Inventor
Nikola Tesla
By his Attorneys
Duncan & Page.

Figure 21.
Another mechanical oscillator with controlling electromagnetic system described in U.S. Patent No. 511,916 of January 2, 1894. Application filed August 19, 1893.

for exercising the controlling force, to obtain it electrically. Boiling water was employed to keep the temperature of the air spring perfectly constant and the oscillations isochronous. I constructed an electromagnetic field so that it could be used for isochronous control. This invention I also exhibited at the Chicago World's Fair where scientific men, Helmholtz and others, saw it. The magnetic field [of the] core generates currents in the coils. Two coils are used for excitation and two for induction. I connect a condenser to the latter and adjust the period of the electromagnetic system, comprising the condenser and the self-inductance, so that it is just suitable for the conditions under which I wish to operate. Then the magnetic system, having a constant period of vibration, controls the admission of the fluid to the piston, and when I use the currents I find them perfectly isochronous. I can run a clock with them and it will show correct time. The vibrations obtained in this way would not vary one-millionth of a second in a thousand years.

The photograph [Fig. 22] shows another form which I also exhibited at the Chicago World's Fair. There is a round coil, you see, in the field; on the other side is another such coil. I performed very curious experiments with this machine. For instance, among other things, I produced direct currents without commutation.

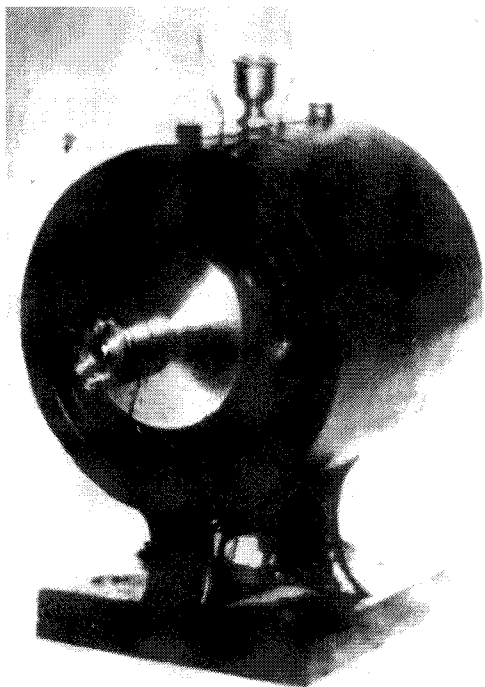

Figure 22.
**Another type of small mechanical
electromagnetically controlled
mechanical oscillator.**

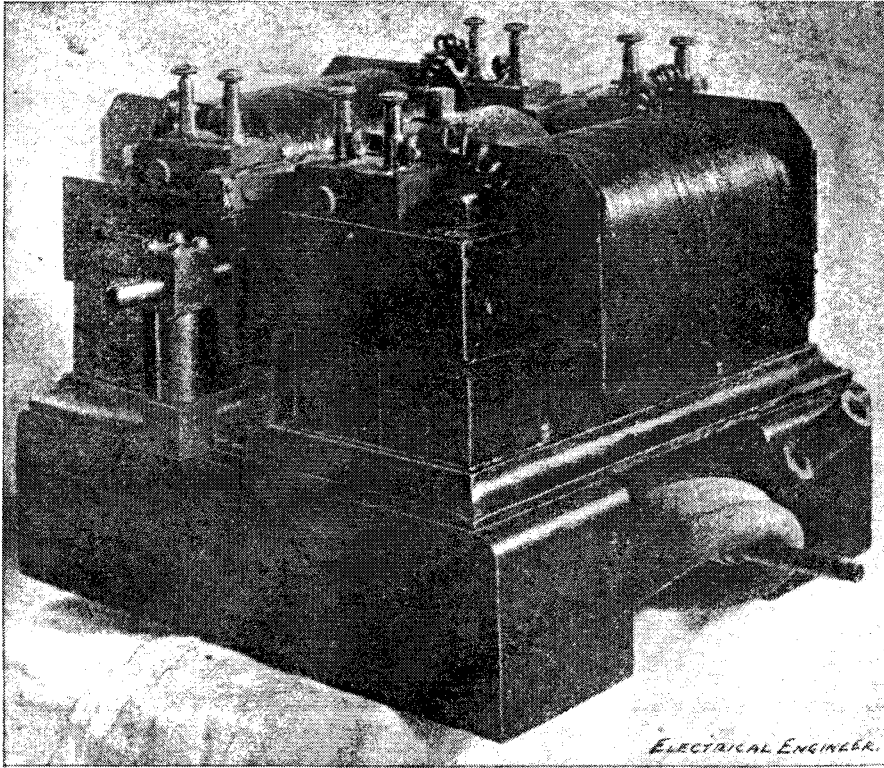

Figure 23.
Large electromagnetically controlled mechanical oscillator for generating isochronous oscillations, used in demonstration before the Electrical Congress at the Chicago World's Fair, August 25, 1893. Illustrated in Martin book, Fig. 312, p. 490.

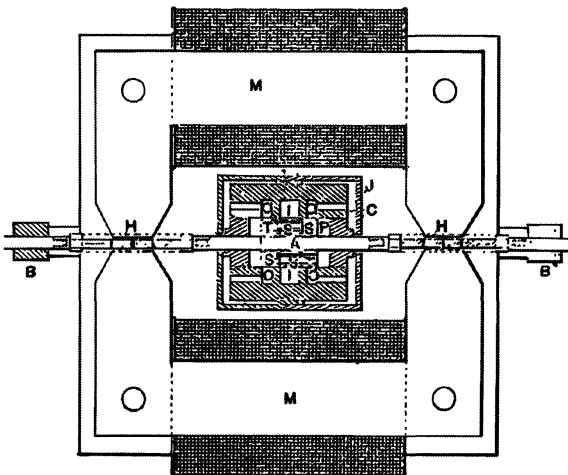

FIG. 313.

Figure 24.
Diagrammatic representation of electro-magnetically controlled mechanical oscillator for generating isochronous oscillations. Shown in Martin book, Fig. 313, p. 491.

Here [Fig. 23] is, I might say, the first commercial oscillator which I designed and constructed and which was exhibited at the Chicago World's Fair. With this, I also performed many experiments. As you will observe, I have a powerful magnet in two parts for producing a strong field on both sides, and in it are conductors which are vibrated by an engine in the center.

That [Fig. 24], as you see, diagrammatically represents the arrangement. Here [at the center] is my little engine, and here [at H and M] are the conductors and the magnets producing a very strong field. I observed very curious phenomena with this machine, which I subsequently turned to great advantage.

We are now coming to a form of machine which was on an industrial scale.

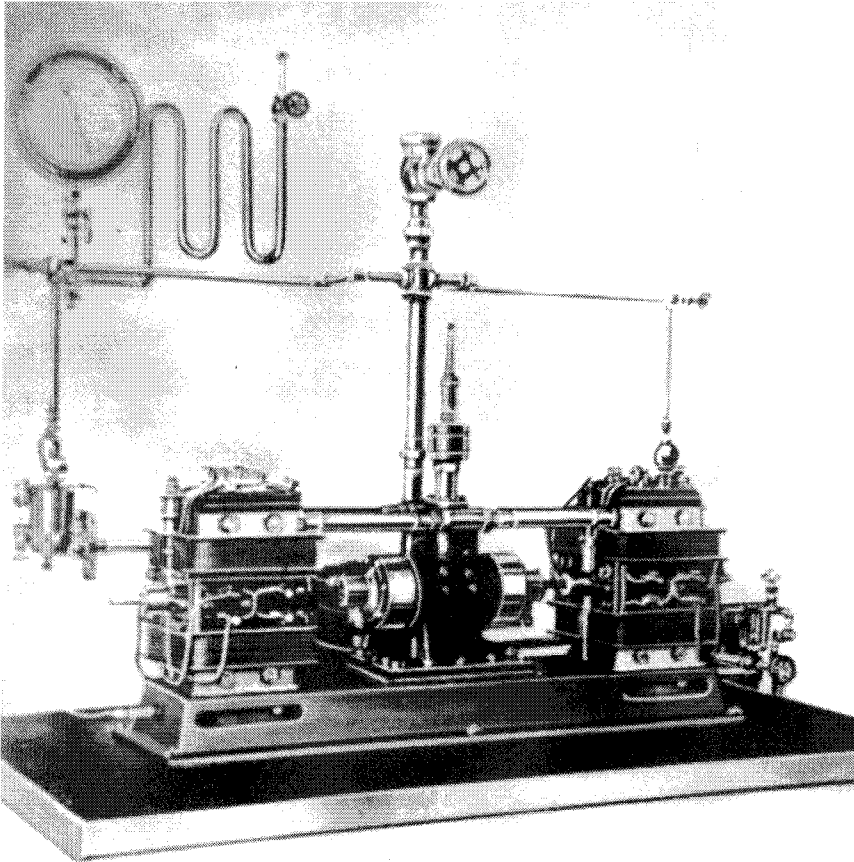

Figure 25.

Double compound mechanical and electrical oscillator for generating current of perfect, constant, dynamo frequency of 10 horsepower. (Article by Martin ["Tesla's Oscillator and Other Inventions"], Century Magazine, April 1895, Fig. 2, p. 921.) (Built in 1893.)

With this one [shown in Fig. 25], I operated normally in my laboratory at 35 South Fifth Avenue. It was primarily installed there. The Babcock and Wilcox people had the kindness of specially constructing a boiler for me which could stand a pressure of 1,000 pounds. This machine was capable of developing up to 10 horsepower. It was, as you see, composed of two magnets or magnetic fields and a compound engine for imparting vibration to the conductors in the fields. It was controlled by an isochronous oscillator and, in addition, I tuned the electromagnetic system when I operated.

Counsel

What frequencies were developed?

Tesla

Those were low frequencies, but I will tell you how I solved the problem of high frequencies.

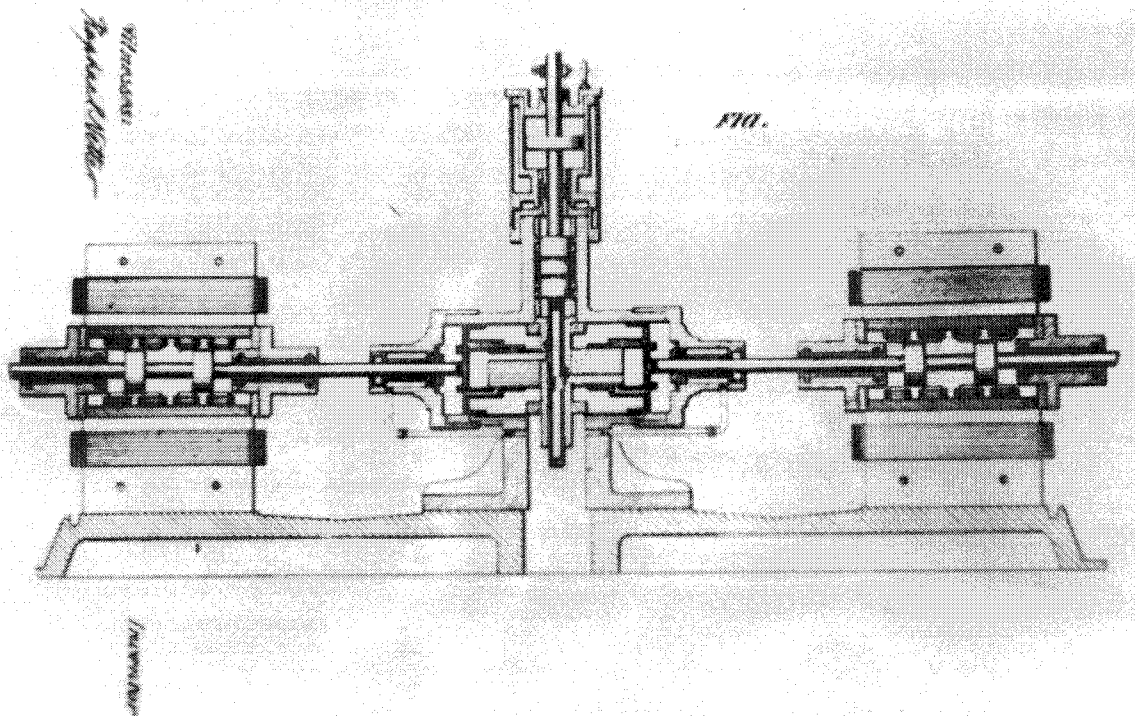

Figure 26.

Diagrammatic representation of double compound mechanical and electrical oscillator for generating currents of perfectly constant dynamo frequency. Shows mechanical and electrical parts.

Counsel

When was that machine developed, Mr. Tesla?

Tesla

This machine was built in 1893 and was operated until May 1895, when a fire destroyed my laboratory. You will appreciate better this photograph [Fig. 25] if I show this drawing [Fig. 26] that was made for the patent specification at that period.

I come now to a large machine which was built in my laboratory on Houston Street. Immediately after the destruction of my laboratory by fire, the first thing I did was to design this oscillator [shown in Fig. 27]. I was still recognizing

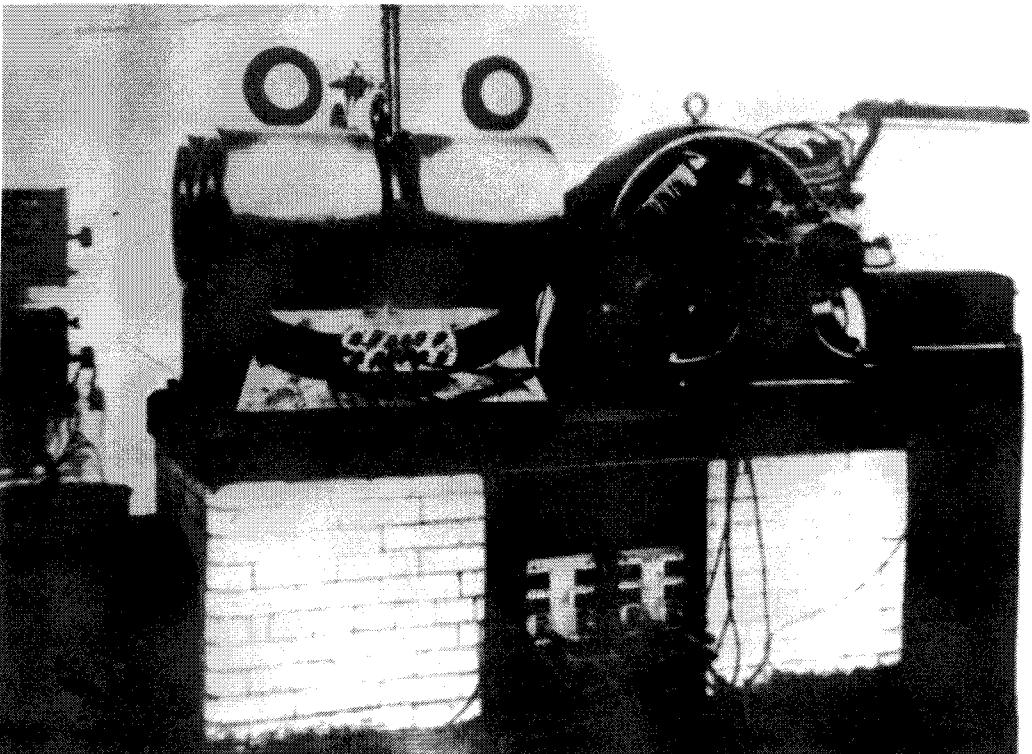

Figure 27.

Large mechanical and electrical oscillator with four vibrating parts installed in the laboratory at 46 E. Houston Street, for furnishing isochronous currents of desired wave frequencies, phases, and beats.

the absolute necessity of producing isochronous oscillations, and I could not get it with the alternator, so I constructed this machine. That was all a very expensive piece of work. It comprised four engines. Those four engines were put in pairs and there was an isochronous controller in the center, and furthermore, that controller was so arranged that I could set two pairs of engines to any phase or produce any beat I desired. Usually I operated quarter phase; that is, I generated currents of 90° displacement.

By the way, now, for the first time you see my apparatus on Houston Street, which I used for obtaining oscillations, damped and undamped as well. But, it is necessary to state that while others, who had been using my apparatus, but without my experience, have produced with it damped oscillations, my oscillations were almost invariably continuous, or undamped, because my circuits were so designed that they had a very small damping factor. Even if I operated with very low frequencies, I always obtained continuous, or undamped, waves for the reason that I designed my circuits as nonradiative circuits. I will explain that later.

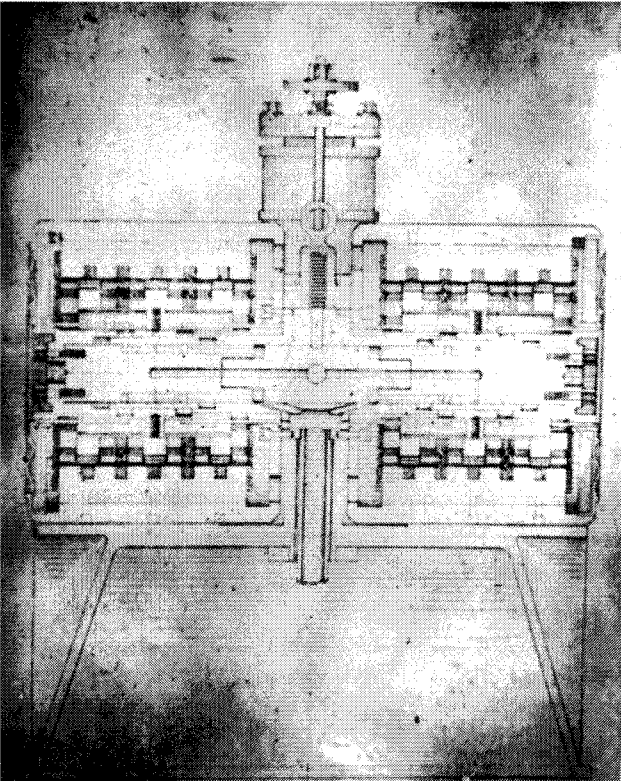

Figure 28.
Diagram showing length
of section of large
mechanical and electrical
oscillator.

In this diagram [Fig. 28] I show the general arrangement of these engines installed in the laboratory at 46 East Houston Street. There were four, with four vibrating parts installed for furnishing isochronous currents of desired wave frequencies, phases, and beats.

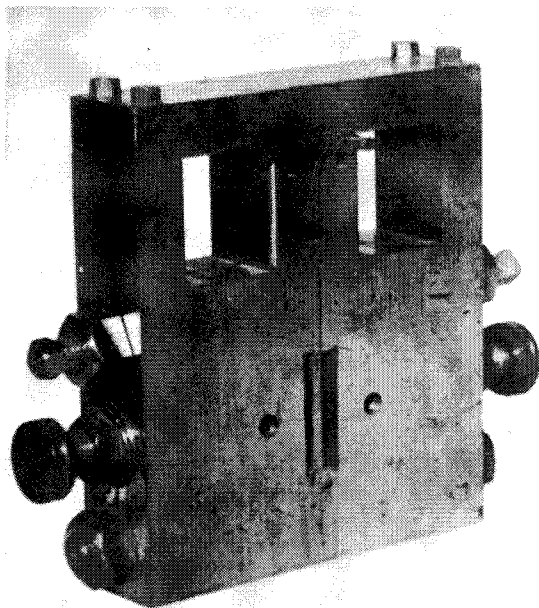

Figure 29.
Small high frequency mechanical and electrical oscillator used in many investigations.

That oscillator [Fig. 29] was one of high frequency for isochronous work, and I used it in many ways. The machine, you see, comprised a magnetic frame. The energizing coil, which is removed, produced a strong magnetic field in this region. I calculated the dimensions of the field to make it as intense as possible. There was a powerful tongue of steel which carried a conductor at the extreme end. When it was vibrated, it generated oscillations in the wire. The tongue was so rigid that a special arrangement was provided for giving it a blow; then it would start, and the air pressure would keep it going. The vibrating mechanical system would fall into synchronism with the electrical, and I would get isochronous currents from it. That was a machine of high frequency that emitted a note about like a mosquito. It was something like 4,000 or 5,000. It gave a pitch nearly that of my alternator of the [first] type which I have described.

Of course this device was not intended for a big output, but simply to give me, when operating in connection with receiving circuits, isochronous currents. The excursions of the tongue were so small that one could not see it oscillate, but when the finger was pressed against it the vibration was felt.

This drawing [Fig. 30] shows the construction in detail. Here is the field coil, here are the conductors in the intense field, the valves for air supply, and the stops for limiting vibration. The stronger the field was excited, the [stronger] the vibrations became, but just the same, while the amplitude changed, the isochronism was not disturbed.

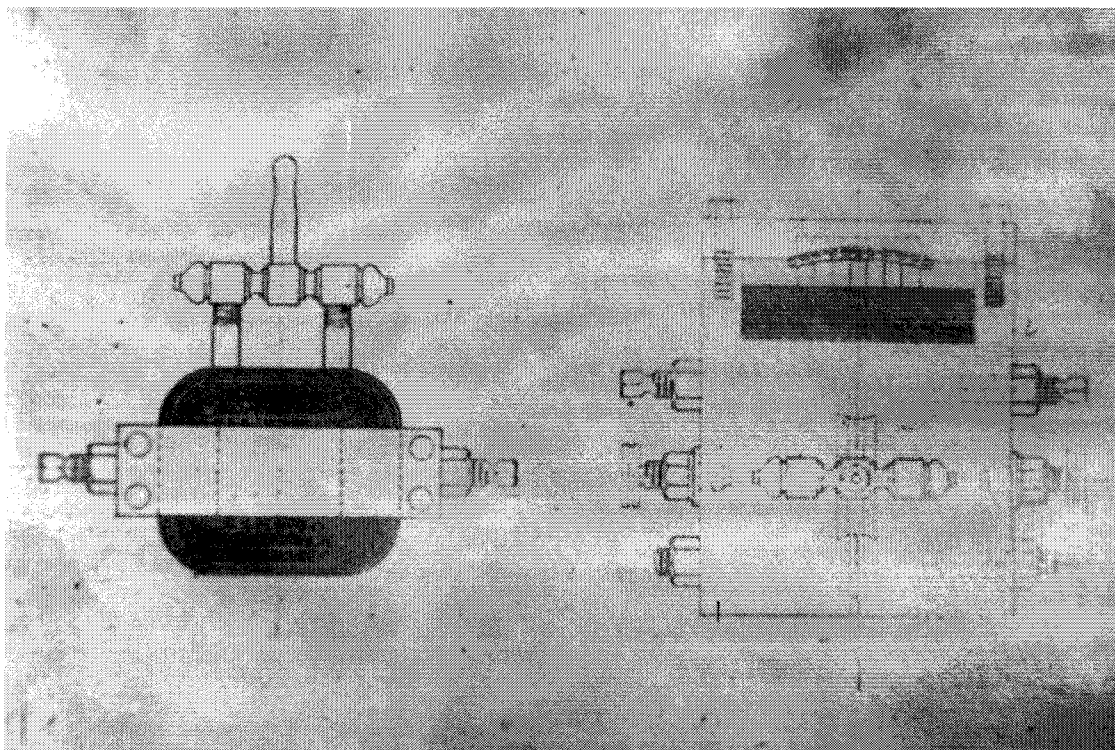

Figure 30.

Diagrammatic representation of small high frequency mechanical and electrical oscillator used in many investigations.

I want to say now why these machines were the means of obtaining the best results in my wireless work. The machine at the Houston Street laboratory with which I could obtain any difference of phase, as well as that machine at 35 South Fifth Avenue, were the means of running a motor in perfect isochronism. That is, if I connected a synchronous motor to these machines and drove it with currents of different phase, I obtained an absolutely uniform rotation -- constant in time -- and when I coupled this motor directly to an alternator, I obtained from the latter currents of absolutely constant frequency, all the more readily as I tuned the circuit of the alternator to the same frequency.

These machines I have described in a general way only. The work has covered years, and it would take a long time to explain all about them. They enabled me to operate in whatever I did with currents of constant frequency, and the small

alternators in my experiments were driven in this way. While this work was going on, I was perfecting various other ways of generating electric oscillations of absolutely constant frequency which were then not producible in the art.

IV. Apparatus for Transformation by Condenser Discharges; Damped Waves

Tesla

This work [Fig. 31] was begun already in 1889. This type of apparatus is identified with my name as certain as the law of gravitation is with that of Newton. I know that some have claimed that Professor [Elihu] Thomson also invented the so-called Tesla coil, but those feeble chirps ne'er went beyond Swampscott. Professor Thomson is an odd sort of man; very ingenious, but he never was a wireless expert; he never could be. Moreover, it is important to realize that this principle is universally employed everywhere. The greatest men of science have told me that this was my best achievement and, in connection with this apparatus [referring to schematics of Fig. 31], I may say that a lot of liberties have been taken. For instance, a man fills this space [break D] with hydrogen; he employs all my instrumentalities, everything that is necessary, but calls it a new wireless system -- the Poulsen arc. I cannot stop it. Another man puts in here [referring to space between self-inductive lines L L] a kind of gap -- he gets a Nobel prize for doing it. My name is not mentioned. Still another man inserts here [conductor B] a mercury[-arc] rectifier. That is my friend [Peter] Cooper Hewitt. But, as a matter of fact, those devices have nothing to do with the performance.

If these men knew what I do, they would not touch my arrangements; they would leave my apparatus as it is. Marconi puts in here [break D] two wheels. I showed only one wheel; he shows two. And he says, "See what happens when the wheels are rotated; a wonderful thing happens!" What is the wonderful thing? Why, when the teeth of the wheels pass one another, the currents are broken and interrupted. That is the wonderful thing that happens? The Lord himself could not make anything else happen unless he broke his own laws. So, in this way, invention has been degraded, debased, prostituted, more in connection with my apparatus than in anything else. Not a vestige of invention as a creative effort is in the thousands of arrangements that you see under the name of other people -- not a vestige of invention. It is exactly like in car couplings on which 6,000 patents have been taken out; but all the couplings are constructed and operated exactly the same way. The inventive effort involved is about the same as that of which a 30-year-old mule is capable. This is a fact.

This is one of most beautiful things ever produced in the way of apparatus: I take a generator of any kind. With the generator I charge a condenser. Then I discharge the condenser under conditions which result in the production of vibrations. Now, it was known since Lord Kelvin that the condenser

(No Model.)

N. TESLA.

METHOD OF AND APPARATUS FOR ELECTRICAL CONVERSION AND DISTRIBUTION.

No. 462,418.

Patented Nov. 3, 1891.

Fig. 1

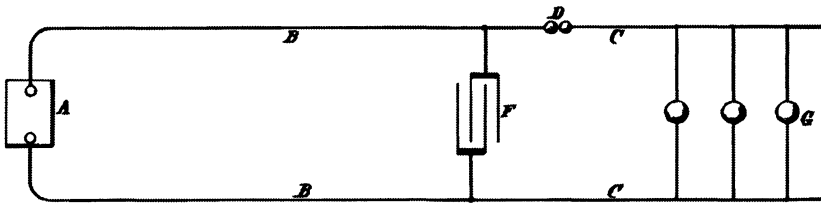
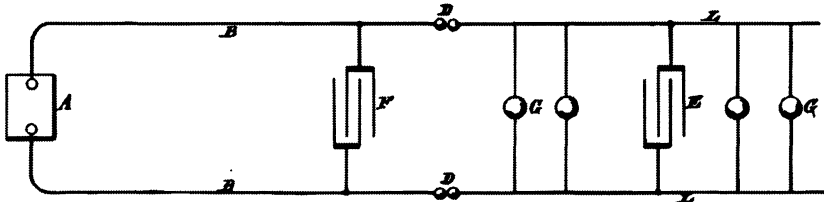

Fig. 2



Witnesses:
Raphael Mitter
Frank A. Murphy.

Inventor
Nikola Tesla
 by *Duncan & Page.*
 Attorneys.

Figure 31.

Method of transformation of electrical energy by oscillatory condenser discharges described in U.S. Patent No. 462,418 of November 3, 1891. Application filed February 4, 1891. Announcement of this invention was made in Tesla's lecture before the American Institute of Electrical Engineers at Columbia College, May 20, 1891, where it was predicted that this apparatus afforded vast possibilities and would play an important part in the future. Illustrated and described in Martin book, Figs. 126 and 127, pp. 191-194.

discharge would give this vibration, but I perfected my apparatus to such a degree that it became an instrument utilisable in the arts, in a much broader way than Lord Kelvin had contemplated as possible. In fact, years afterwards when Lord Kelvin honored me by presenting to the British Association one of my oscillators of a perfected form, he said that it was "a wonderful development and destined to be of great importance."

[Returning to a discussion of Fig. 31], [E] is supposed to be a condenser. That [A] is the generator. Now then, supposing that this is a generator of steady pressure. I can obtain oscillations of any frequency I desire. I can make them damped or undamped. I can make them of one direction or alternating in direction as I choose. At G are devices which operate -- lamps, or anything else. Some experimenters who have gone after me have found a difficulty. They said,

"No, we cannot produce a constant train of oscillations."

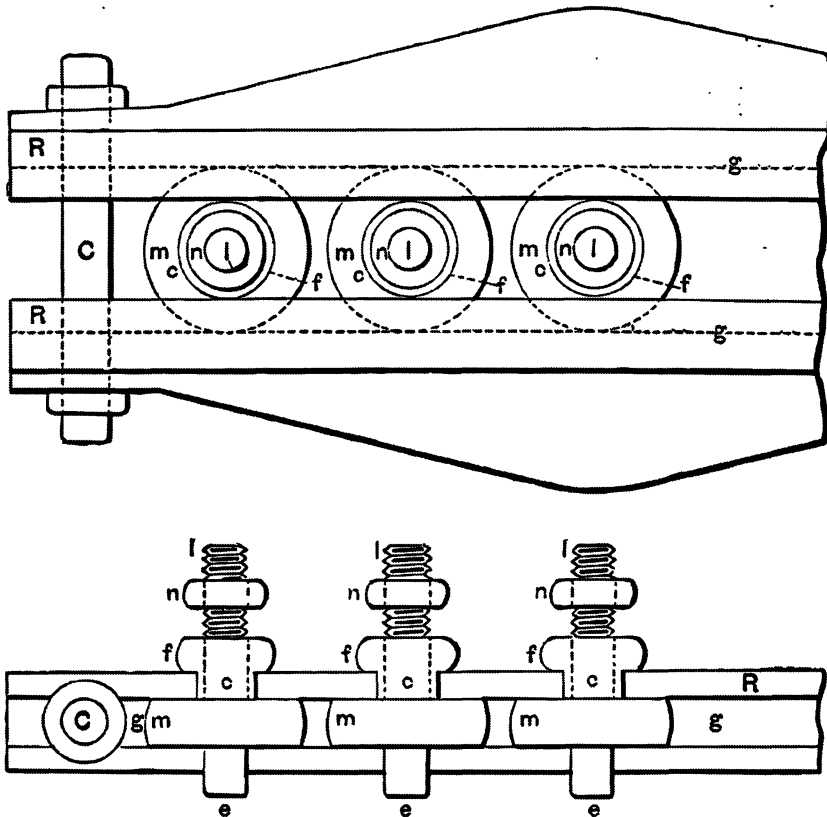

Figure 32.

Quenched spark gap. (Tesla at that time pointed out the future of quenching and showed that oscillations can be maintained without a spark being visible to the naked eye between the knobs.) Illustrated in Martin book, Figs. 135 and 136, p. 211.

Well, it is not my fault. I never have had the slightest difficulty. I produced constant oscillations and I have described how I produced them. Anyone who has no more than my own skill can do it.

This [Fig. 32] is another improvement in that particular device, which was the weakness of the invention and which I tried to eliminate. This device incorporated many spark gaps in series. It had a peculiar feature; namely, through the great number of gaps, I was able, as I have pointed out in my writings, to produce oscillations without even a spark being visible between the knobs. This device is now known in the art as the "quenched spark gap." Professor Wein has formulated a beautiful theory about it, which I understand has netted him the Nobel prize. Wein's theories are admirable. The only trouble is that he has overlooked one very important fact. It is this: If the apparatus is properly designed and operated, there is no use for the quenched gap, for the oscillations are continuous anyway. The radio men who came after me had the problem before them of making a bell sound, and they immersed it in mercury. Now, you know mercury is heavy. When they struck their bell, the mercury did not permit it to vibrate long because it took away all the energy. I put my bell in a vacuum and make it vibrate for hours. I have designed circuits in connection with an enterprise in 1898 for transmission of energy which, once started, would vibrate three years, and even after that the oscillations could still be detected. Professor Wein's theory is very beautiful, but it really has no practical meaning. It will become useless as soon as the inefficient apparatus of the day, with antennae that radiate energy rapidly, [are] replaced by a scientifically designed oscillator which does not give out energy except when it gets up to a tremendous electromagnetic momentum.

Figure 33.

The discharger working in an atmosphere, chiefly consisting of hydrogen, still further weakened by heat. The use of hydrogen in this connection has been claimed as a discovery and patented. Presented in Tesla's lectures before the Franklin Institute and the National Electric Light Association. Martin book, Fig. 167, pp. 307-308.

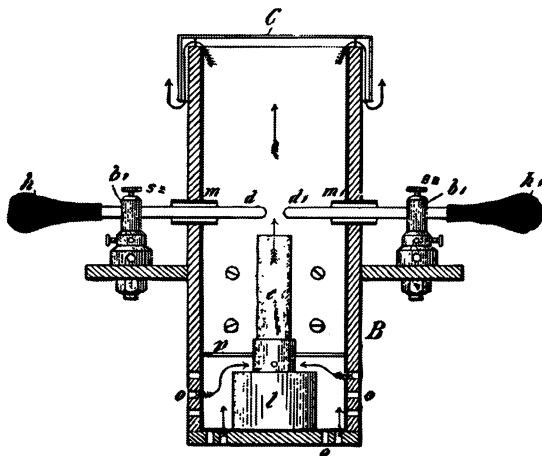

FIG. 167.

In this form of break [Fig. 33], I changed the atmosphere in which the arc was operating. The atmosphere was mostly hydrogen, and with this device I performed my experiments before the Franklin Institute in Philadelphia and the National Electric Light Association in St. Louis. This has been used by Poulsen and it is now called the "Poulsen arc" and "Poulsen system." But, of course, there is no invention in it. I am on record with prior publications, and besides, the hydrogen does not have any other effect except that it lowers the tension under which the device can operate. It has the disadvantage of producing asymmetrical or distorted waves, and the impulses obtained are not best suited for tuning.

This [Fig. 34] is the apparatus used in the Chicago Exposition of 1893, at which time I explained for the first time to Professor Helmholtz my plan for transmitting energy. After I had shown Professor Helmholtz and other scientific men there certain phenomena, he asked me,

"Now, what is all this intended for?"

I told him I was trying to develop an apparatus for transmitting energy without wire for telegraphy, telephony, and other purposes. When I explained to Professor Helmholtz the whole idea, I said,

"Excellency, do you think that my plan is realizable?"

He replied,

"Why, certainly it is, but first you must produce the apparatus."

I started then and there to produce the apparatus.

Counsel

Was that conversation at the Chicago Exposition?

Tesla

Yes. It took place in a pavilion which was built especially for exhibiting my inventions and discoveries. I believe Professor Wedding was there and some other scientists whom I cannot remember now. I showed Professor Helmholtz my vacuum tubes and performed many other experiments.

Counsel

Will you describe this apparatus in a little more detail?

(No Model.)

N. TESLA.

MEANS FOR GENERATING ELECTRIC CURRENTS.

No. 514,168.

Patented Feb. 6, 1894.

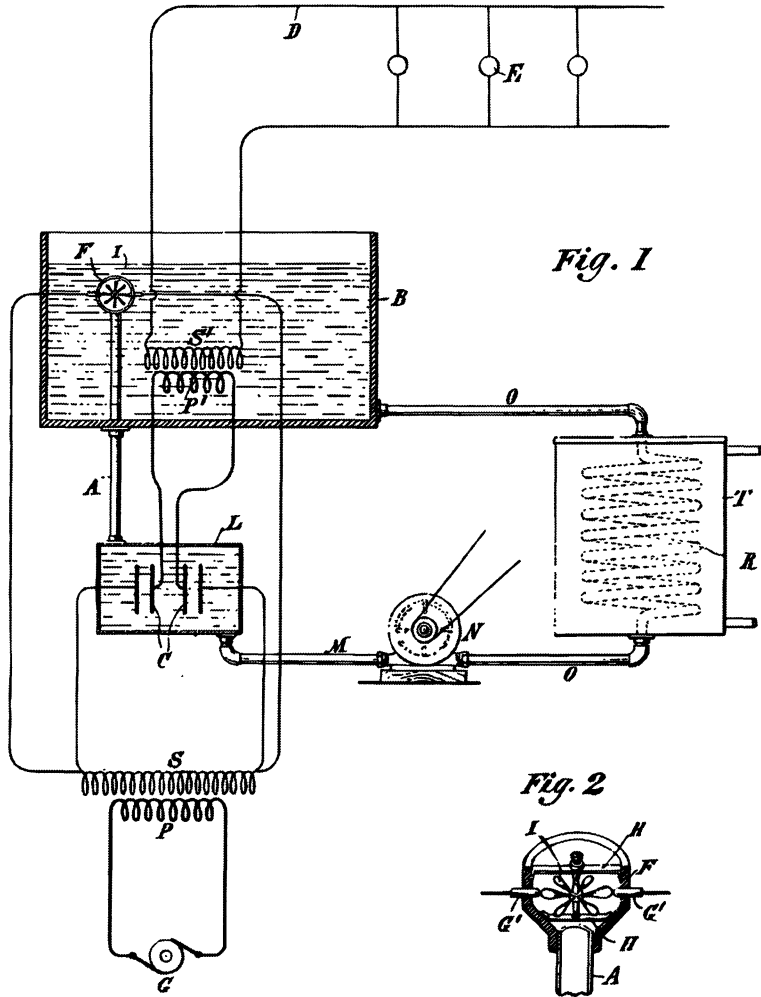

Witnesses
Raphael Netter
James H. Keenan

Inventor
Nikola Tesla
 By his Attorneys
Duncan Page

Figure 34.
 Oscillatory apparatus with interrupter in oil. Exhibited in the Chicago Exposition of 1893 before Helmholtz. Described in U.S. Patent No. 514,168 of February 6, 1894. Application filed August 2, 1893.

Tesla

The apparatus [Fig. 34], as you see, comprised primary and secondary coils immersed in a large tank of oil. The break was automatically effected by means of a turbine. The oil was circulated by a pump, and the current [i.e., stream flow] of oil drove the turbine which effected the make and break. Owing to the fact that the oil used was a very good insulator, rapidly flowing and of great dielectric strength, these make-and-break points were very close together, and the arcs extremely short. The effects were accordingly more intense. Here [T in Diag. 1 of Fig. 34] is a cooler through which the oil was circulated. The oil was forced through the gaps at great speed, and as it flowed out it was supplied again to the tank and the current driving the turbine.

Counsel

That device [Diag. 2 of Fig. 34] you call a turbine?

Tesla

Yes. It had vanes like those of a propeller and constituted a rotary break in the circuit.

Counsel

What was your prime source [of power]?

Tesla

The primary source was an alternator with a frequency of 133 cycles and, if I recollect rightly, the pressure [at the secondary] was about 20,000 volts. I may have had 10,000 volts. I am not sure what it was, but it must have been certainly from 10,000 to 20,000 volts -- within that range.

Counsel

I notice you have two sets of transformers in there marked S and S', have you not?

Tesla

This [S'] is my oscillatory circuit. That [S] is the transformer from which the condenser was charged. Here [at S] we had 20,000 volts, or whatever it was, from the commercial transformer and here [at S'] is my secondary which generated the high frequency currents. The rotary gap is shown in detail [Diag. 2 of Fig. 34].

I had a special reason for showing this. To meet that great man Helmholtz and other scientific men, and to bring

before them for the first time the results of years of previous labor, was an important moment in my life -- particularly because Professor Helmholtz gave me the assurance himself that what I explained to him was realizable, provided that I could produce the apparatus. I was very much encouraged.

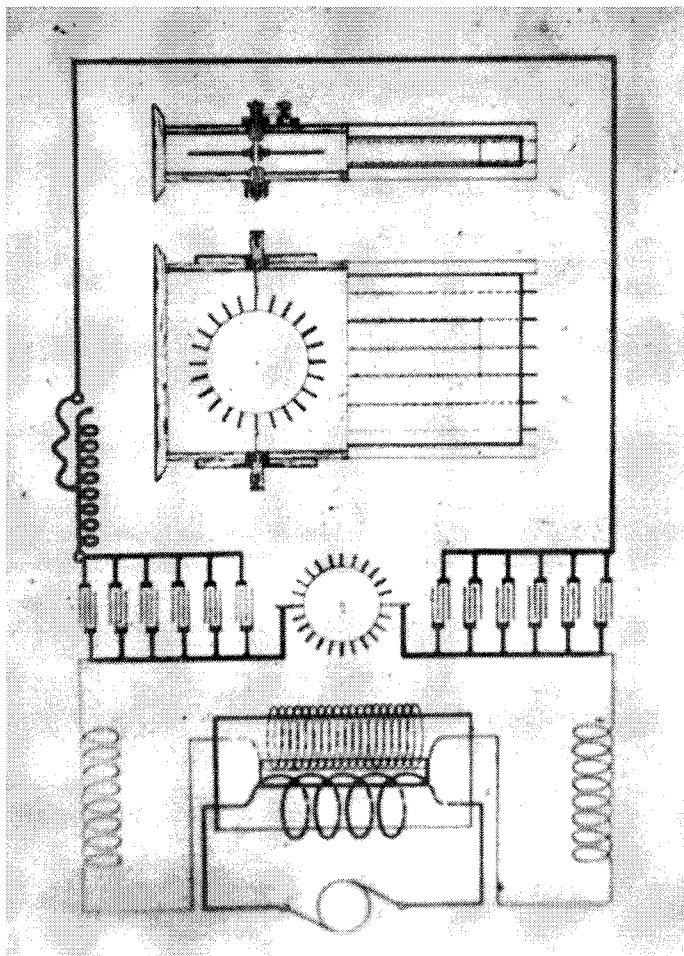

Figure 35.

Apparatus with mechanical break as installed on a large scale in the laboratory at 35 So. Fifth Avenue and subsequently at 46 E. Houston Street. Described in U.S. Patent No. 645,576 of March 20, 1900. Application filed September 2, 1897.

This [Fig. 35] is the apparatus I had at 35 South Fifth Avenue and also Houston Street. It shows the whole arrangement as I had it for the demonstration of effects which I investigated.[*] This cable you see [square loop in top half of Fig. 35] is stretched around the hall. These are my condensers. There is the mechanically operated break, and that is a transformer charged from the generator. That is the way I had it for the production of current effects which were rather of damped character because, at that period, I used circuits of great activity which radiated rapidly. In the Houston Street laboratory, I could take in my hands a coil

* Editorial note: This diagram is not provided in the referenced patent.

tuned to my body and collect 3/4 horsepower anywhere in the room without tangible connection, and I have often disillusioned my visitors in regard to such wonderful effects. Sometimes, I would produce flames shooting out from my head and run a motor in my hands, or light six or eight lamps. They could not understand these manifestations of energy and thought that it was a genuine transmission of power. I told them that these phenomena were wonderful, but that a system of transmission, based on the same principle, was absolutely worthless. It was a transmission by electromagnetic waves. The solution lay in a different direction. I am showing you this [diagram] simply as a typical form of apparatus of that period, and if you go over the literature of the present day you will find that the newest arrangements have nothing better to show.

Counsel

What was the make and break frequency that you got from that apparatus?

Tesla

It was 5,000, 6,000 -- sometimes higher still. I had two oppositely rotating discs which I will show you and with which I could have reached, probably, 15,000 or 18,000.

Counsel

What wave frequencies did you develop?

Tesla

I could operate from a few thousand up to a million per second, if I wanted.

Counsel

What did you actually use?

Tesla

In these demonstrations, which I showed these effects, these most powerful effects that were [in] the sight of New York at that time, I operated with frequencies from 30,000 to 80,000. At that time I could pick up a wire, coil it up, and tell what the vibration would be, without any test, because I was experimenting day and night.

This [Fig. 36] is a form of break which I developed in working with alternators. I recognized that it was of tremendous advantage to break at the peak of the wave. If I used just an ordinary break, it would make and break the current at

(No Model.)

2 Sheets—Sheet 2.

N. TESLA.

APPARATUS FOR PRODUCING ELECTRICAL CURRENTS OF HIGH FREQUENCY.

No. 568,180.

Patented Sept. 22, 1896.

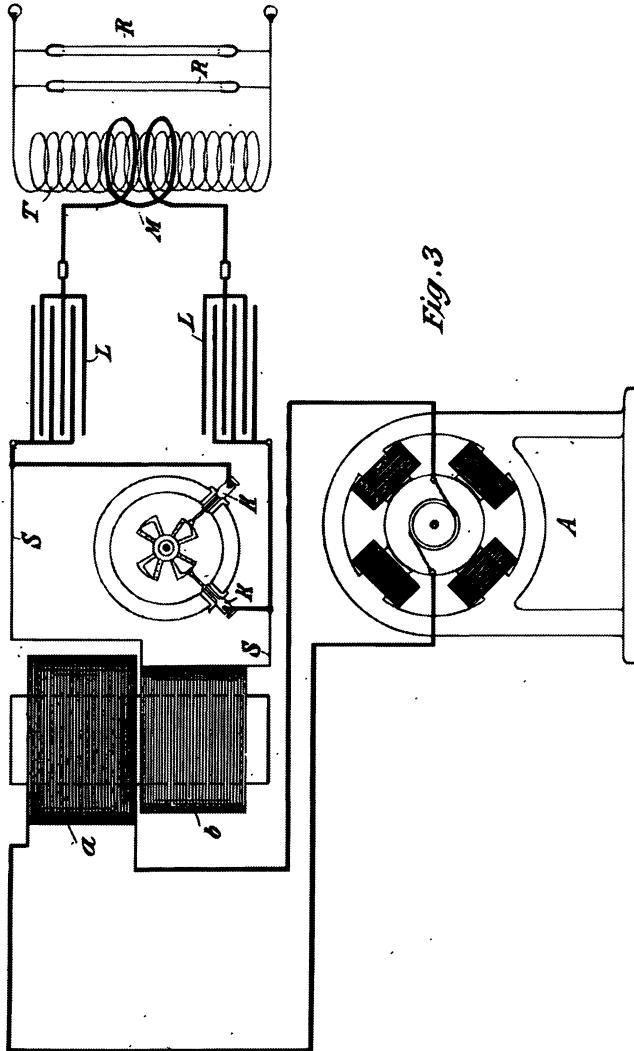

WITNESSES:
Edwin B. Hopkinson.
Benjamin J. ...

Nikola Tesla INVENTOR

BY
Herr, Curtis & Page, ATTORNEYS

Figure 36.
 Isochronous mechanical break used in the laboratory at 35 South Fifth Avenue. Described in U.S. Patent Nos. 568,179 and 568,180 of September 22, 1896. Applications filed July 6 and 9, 1896. (Diagram taken from Patent No. 568,180.)

low as well as high points of the wave. Of this apparatus I had two forms; one in which I drove the break right from the shaft of the dynamo and the other in which I drove it with an isochronous motor. Then, by a movement of these knobs (K K), I would make the adjustments so that the makes would occur exactly at the top of the wave. That is a form of break which is embodied in hundreds of patents and used now extensively.

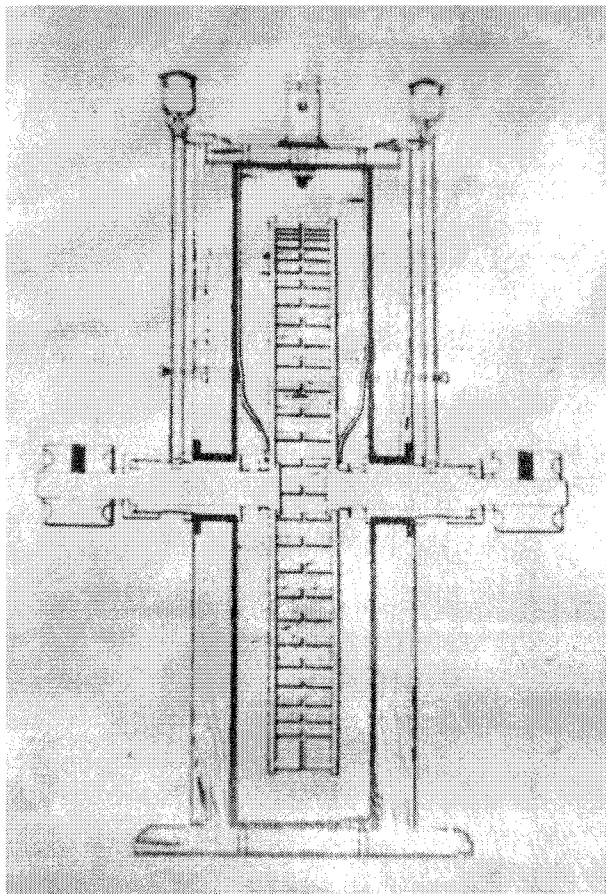

Figure 37.
Mechanical break with two oppositely rotating discs used for the purpose of increasing the number of breaks and alternating the oscillations practically undamped. (Subsequently patented by others.)

Here [Fig. 37] I show an apparatus that was installed in the Houston Street laboratory prior to the other break because I wanted to get as high a number of impulses as possible. The drawing dates from the spring of 1896. It is a break with which I could reach from 15,000 to 18,000 interruptions per second. I used it very much until later I found it was not necessary. That is the innocent device which Marconi thought a great invention.

Counsel

This is also a rotary gap?

Tesla

Yes, and it consists of two discs of aluminum, with teeth of aluminum on the side. They were rotated by two motors in opposite directions, and as they rotated they alternately closed and opened the circuit. In some instances I used an uneven number of teeth on one and an even number on the other so that I could produce as many breaks as I desired. I will show you later an apparatus more perfect than this one, and of a different kind, in which I have 24 stationary contacts, and 25 rotating elements that established the contact and broke it, so that by one revolution I obtained 24 times 25, or 600 interruptions [per revolution].

Counsel

Whenever you say "the break", you mean "a spark gap"?

Tesla

Yes; otherwise I use the term "circuit controller," preferably.

This [Fig. 38] illustrates another development in a different direction. In order to increase the number of breaks, I employed currents of different phase. I had in my laboratory, permanently, a two-phase dynamo and could get phases between; that is, from two phases, 90 apart, I could obtain four phases, 45 apart. Here is an arrangement shown as I had it, working with three phases [60 apart, and could obtain six phases, 30 apart], and later on I had one with four phases [45 apart, and could obtain eight phases 22 1/2 apart]. You see, as I multiplied the number of the phases, I increased the number of the fundamental discharges.

Counsel

What is the date of this apparatus?

Tesla

This I employed already in the 35 South Fifth Avenue laboratory, because I remember that I gave entertainments to several scientific societies and it was then present there. I know on one occasion there was the Society of Architects, and another, the Electrotherapeutic Society, and then I had distinguished men like Mark Twain and Joseph Jefferson -- I gave them a demonstration which was published in Martin's article in the Century Magazine of April 1895, and I know that on these occasions I used a two-phase arrangement. Later on I made it four phase. That apparatus existed, therefore, prior to the destruction of my laboratory in 1895.

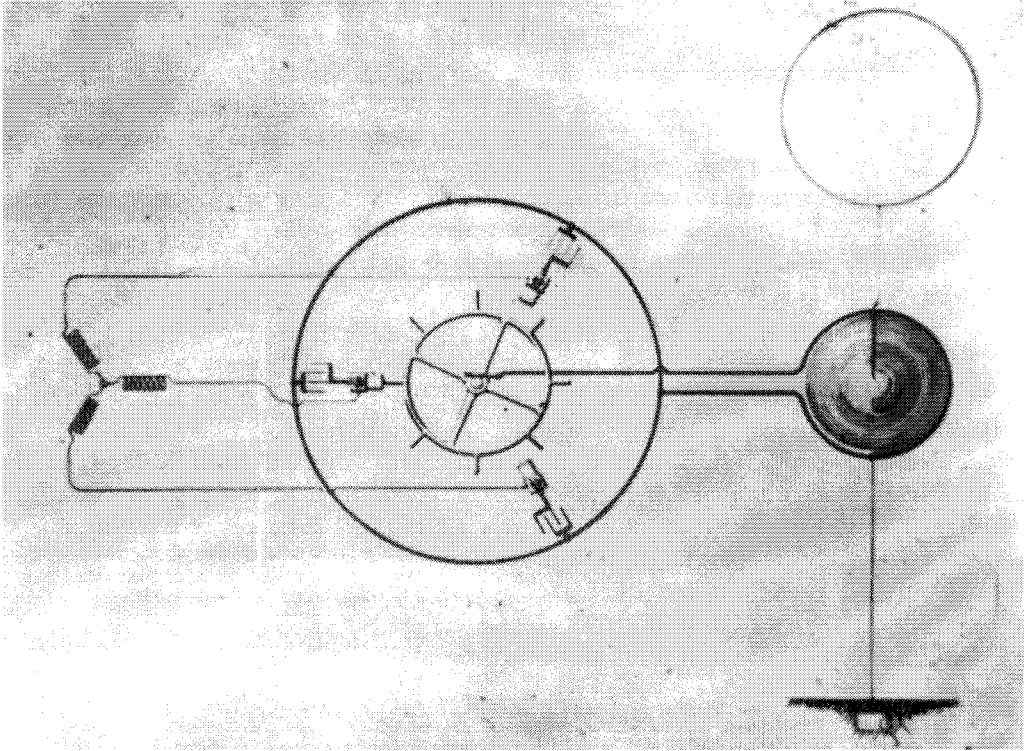

Figure 38.

Use of multi-phase generator with mechanical break. Experiments in the laboratory at 35 So. Fifth Avenue and subsequently.

Counsel

Do you recall any publication in which this diagram was illustrated?

Tesla

I made no publication, and I vividly remember that when I installed my apparatus on Long Island I had an arrangement with four transformers and four phases 45° apart. After I had been using this apparatus there, several years afterwards, I ran across a patent, I believe held by the General Electric Company, describing precisely the same arrangement.[*] It was a similar experience as with that patent of Fessenden on the compressed air condenser. Any time I want to use these improvements all I need to do is to produce my records and that will settle the patents.

Counsel

When was that drawing [Fig. 38]?

* Editorial note: Tesla refers to U.S. Patent No. 996,580 dated June 27, 1911, of Charles Green with assignment to G.E.; application filed September 30, 1907.

Tesla

This is from an old patent drawing which was made by Mr. Netter.

Counsel

But that did not go to patent?

Tesla

No. I have hundreds of inventions that were to be patented but side-stepped. The expense was too great and I could not do it. This form of apparatus with two and four phases was used prior to the destruction of my laboratory in 1895, and it was installed on a large scale with four phases in my plant on Long Island with which I was to telephone around the world, but that is a long story.

Counsel

In that use you made of it at your laboratory, was that connected up as shown there [Fig. 38], to an antenna?

Tesla

I used the apparatus, yes, in connection with the antenna too, but this is from a patent drawing in which an antenna is shown; I mean, I used it in every connection. [Fig. 38] illustrates an antenna with my transmitting circuit, but the apparatus was used in all my work, in all my investigations.

Counsel

And when this was connected in and used in an antenna, did you use it as in other instances -- go off and listen to the notes which you received?

Tesla

Oh, certainly. But I remember that, besides this, I had different kinds of apparatus. Then I had a sensibly damped wave because at that time I still was laboring under the same difficulties as some do this day -- I had not learned how to produce a circuit which would give me, with very few fundamental impulses, a perfectly continuous wave. That came with the perfection of the devices. When I came to my experiments in Colorado, I could take my apparatus like that and get a continuous or undamped wave, almost without exception, between individual discharges.

Counsel

Speaking of your not having perfectly undamped waves at that time, you were referring to that character of circuit?

Tesla

Yes, but with another kind of circuit I could, of course. The advantage of this apparatus was the delivering of energy at short intervals whereby one could increase activity, and with this scheme I was able to perform all of those wonderful experiments which have been reprinted from time to time in the technical papers. I would take energy out of a circuit at rates of hundreds or thousands of horsepower. In Colorado, I reached 18 million horsepower activities, but that was always by this device: Energy stored in the condenser and discharged in an inconceivably small interval of time. You could not produce that activity with an undamped wave. The damped wave is of advantage because it gives you, with a generator of 1 kilowatt, an activity of 2,000, 3,000, 4,000, or 5,000 kilowatts; whereas, if you have a continuous or undamped wave, 1 kilowatt gives you only wave energy at the rate of 1 kilowatt and nothing more. That is the reason why the system with a quenched gap has become popular.

I have refined this so that I have been able to take energy out of engines by drawing on their momentum. For instance, if the engine is of 200 horsepower, I take the energy out for a minute interval of time, at a rate of 5,000 or 6,000 horsepower, then I store [it] in a condenser and discharge the same at the rate of several millions of horsepower. That is how these wonderful effects are produced. The condenser is the most wonderful instrument, as I have stated in my writings, because it enables us to attain greater activities than are practical with explosives. There is no limit to the energy which you can develop with a condenser. There is a limit to the energy which you can develop with an explosive.

A common experiment, for instance, in my laboratory on Houston Street, was to pass through a coil energy at a rate of several thousand horsepower, put a piece of thick tinfoil on a stick, and approach it to that coil. The tinfoil would melt, and would not only melt, but while it was still in that form, it would be evaporated and the whole process took place in so small an interval of time that it was like a cannon shot. Instantly I put it there, there was an explosion. That was a striking experiment. It simply showed the power of the condenser, and at that time I was so reckless that in order to demonstrate to my visitors that my theories were correct, I would stick my head into that coil and I was not hurt; but, I would not do it now.

[Fig. 39] shows a four-phase machine which was furnished me by the Westinghouse Electric Company at the close of 1895. My laboratory burned out in May, and I urged my friend, Mr. Albert Schmidt, who was the Superintendent, to give me this alternator as soon as possible. He worked day and night until he got it out, and he certainly did notable work because while the machine was rated at 30 horsepower, I have run it at 150 horsepower.

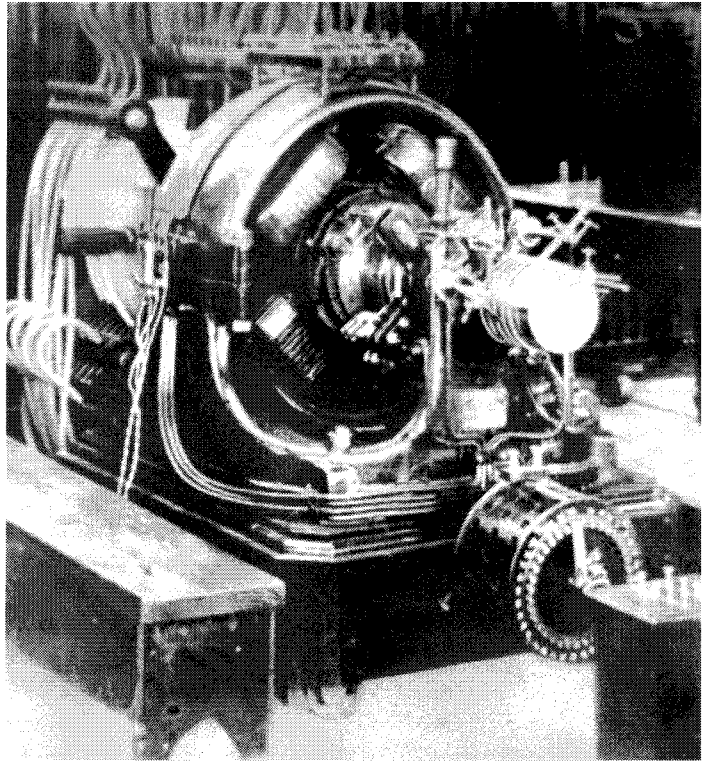

Figure 39.
Apparatus furnishing direct currents of high tension, producing undamped electrical oscillations of high frequency. (This is also shown in [Fig. 27]). Apparatus built in 1895.

By the way, and this is a painful reflection, it was Schmidt and I who developed this type of frame and this general arrangement which is universally adopted now -- a base, with the magnets cast below, split at the center line, and a corresponding upper part. That is now used everywhere. I remember years ago, some of my friends, Messrs. Crocker and Wheeler, started with those long magnets and I told them, "The sooner you throw these away and adopt this construction, the better it will be for you." They have got it now; it is all right.

Counsel

How is this machine [Fig. 39] shown in connection with that?

Tesla

This dynamo [Fig. 39], you see, is a two-phase machine; that is, I develop from it currents of two-phase. Now, there are four transformers, you see them down here [lower left of Fig. 39], that furnish the primary energy. From these two phases I develop four phases. [However,] this involves something else which I have referred to before; namely, an arrangement which enables me to produce from these alternating currents direct currents and undamped -- absolutely undamped -- isochronous oscillations of any period I like.

This is accomplished in the following manner: The secondaries of the four transformers could each develop 44,000 volts. They were specially built for me by the Westinghouse Company. They could, however, be connected in such a way that each would give 11,000 volts, and then I would take these 11,000 volts and these four phases and commutate them by a commutator consisting of aluminum plates, or aluminum segments, which were rotated in synchronism with the alternator. Then I obtained a continuous pressure; that is, direct current of a tension of 44,000 volts, and with these 44,000 volts I charged my condensers. Then by discharging the condensers, either through a stationary gap or through a gap with a mechanical interrupter, I obtained any frequency I desired, and perfectly undamped waves. This arrangement was installed in 1901 in my wireless plant at Long Island, with which I was to telephone around the world.

Counsel

Who built that machine?

Tesla

The Westinghouse Company, [under direction of] Mr. Albert Schmidt, Superintendent. It was especially built for me and furnished to my laboratory on Houston Street.

While I was with the Westinghouse Company, I did two things in addition to bringing my motors to them. I had discovered that Bessemer steel was a much better material for transformers and motors than the soft iron which was previously used. When I came to Pittsburgh, my motors gave results which their motors could not at first produce, and I told them that I had used Bessemer steel. I discovered, in following up the analysis of the steels which were used, that the Bessemer was not steel but really soft iron. The Westinghouse people then adopted my suggestion. At first, Mr. Shallenberger and other electricians there objected very much, but I persuaded them and when the transformers were built we found that we could get 2 1/2 times the output we got before.

The Westinghouse people kept it a secret for a long time and no one understood how they could make such fine transformers, but all they did was to use the Bessemer steel, on my suggestion, instead of the soft iron the General Electric and other people used. Mr. Westinghouse especially requested me to join efforts with Mr. Schmidt and improve the design of his machines, and we did so. We evolved this design, introduced the ready-made coils, which are pressed on the armature, and other improvements. I took a couple of patents out with Mr. Schmidt, and Mr. Westinghouse was very nice about it. I think he compensated me with \$10,000, or something like that, for my suggestions.

Counsel

You have spoken of the use of that machine at Houston Street. In what way was it used?

Tesla

I used this machine, as I said, either to produce alternating currents and then interrupt them with a mechanical break at the high peaks of the wave; or, I used alternating currents and interrupted them with an independent rotating break having a great number of teeth. Or, I generated continuous currents by commutating the high tension alternating currents of the transformer. At that time I had two transformers from which I obtained a constant pressure, charged the condenser, and produced undamped waves of any frequency I wanted. As to the machine here [Fig. 39], that is the way it was arranged. It was for the generation of continuous electromotive force and production of undamped waves -- from 1895 and on.

Counsel

What sort of apparatus was it connected up to for the purpose of absorbing these waves?

Tesla

It was the same as shown here [Fig. 38]. It was connected to the condensers, and these condensers were discharged through a primary which excited the secondary; the antenna was included in the secondary. At other times we discharged the condensers directly so that I could use the antenna without the secondary.

Counsel

In the same way did you note the operation of these waves?

Tesla

We did, of course, only in most cases the instrument of reception was different. When I operated with these continuous, or undamped, waves, generated in this way, I usually went to high frequencies. I did operate [at] a very few thousand, but that gave me a smaller output. Such a machine you have to operate at high frequencies to get power.

Counsel

What do you mean by high frequencies?

Tesla

I mean frequencies of 30,000, 40,000, 50,000, or something like that.

Counsel

And by means of that machine, you put undamped waves of frequency about 50,000 into that antenna at Houston Street in 1895?

Tesla

No, not in 1895. Late in 1895 the machine was furnished and I began to operate in early 1896. That is when I began to operate.

Counsel

Then you did this, that I speak of, in 1896?

Tesla

Yes, from 1896 to 1899, right along.

Counsel

When you used frequencies like that in your antenna, was your antenna tuned or untuned?

Tesla

I could not use it untuned. That would be absurd.

Counsel

What form of device did you use, and where did you use it, for noting the generation of these oscillations or waves in the antenna?

Tesla

I suppose I had hundreds of devices, but the first device that I used, and it was very successful, was an improvement on the bolometer. I met Professor Langley in 1892 at the Royal Institution. He said to me, after I had delivered a lecture, that they were all proud of me. I spoke to him of the bolometer, and remarked that it was a beautiful instrument. I then said,

"Professor Langley, I have a suggestion for making an improvement in the bolometer, if you will embody it in the principle."

I explained to him how the bolometer could be improved. Professor Langley was very much interested and wrote in his notebook what I suggested. I used what I have termed a small-mass resistance, but of much smaller mass than in the bolometer of Langley, and of much smaller mass than that of any of the devices which have been recorded in patents issued since. Those are clumsy things. I used masses that were not a millionth of the smallest mass described in any of the patents, or in the publications. With such an instrument, I operated, for instance, in West Point -- I received signals from my laboratory on Houston Street in West Point.

Counsel

This was then the machine that you used when working with West Point?

Tesla

I operated once or twice with it at that distance, but usually as I was investigating in the city. My work at that time was to prepare for the development of a commercial plant, and with me the question was not to transmit signals, but to see what intensity I could get to put me in position to calculate out my apparatus, the dimensions and the forms, before I began the undertaking. It was nothing but preparatory work for the construction of a commercial plant, and I demonstrated its practicability through my experiments, a plant which was to accomplish much more than all others.

Counsel

What was the horsepower activity in the oscillating circuits when you used this machine?

Tesla

Usually something like 50 horsepower, and I would get, I should say, approximately 30 horsepower in the antenna; that

is, I would get 30 horsepower in the oscillating circuit.

Counsel

I understood a little while ago when you made the statement of using several thousand horsepower put into a condenser, you could take out of the condenser a million horsepower. I wondered if you got the same condition with this machine.

Tesla

Yes; I charged the condenser with 40,000 volts. When it was charged full, I discharged it suddenly, through a short circuit which gave me a very rapid rate of oscillation. Let us suppose that I had stored in the condenser 10 watts. Then, for such a wave there is a flux of energy of $(4 \times 10^4)^2$, and this is multiplied by the frequency of 100,000. You see, it may go into thousands or millions of horsepower.

Counsel

What I wanted to get at was, did that depend upon the suddenness of the discharge?

Tesla

Yes. It is merely the electrical analogue of a pile driver or a hammer. You accumulate energy through a long distance and then you deliver it with a tremendous suddenness. The distance through which the mass moves is small -- the pressure immense.

Counsel

Did you find that that was the best condition for transmitting energy without the use of wire?

Tesla

No, I did not use that method when I was transmitting energy. I used it only in the production of those freaks for which I have been called a magician. If I had used merely undamped waves, I would have been an ordinary electrician like everybody else.

Counsel

You have referred to some delicate receiving instruments. Did you have any trouble with those burning out on account of static?

Tesla

My dear sir, I burned out so many instruments before I discovered what was the matter with them! They burned out instantly until I learned how to make them so that they could not burn out. Yes, that was a great trouble in the beginning.

Counsel

Did you succeed in getting them so they would not burn out?

Tesla

Yes. If lightning struck close by, it would not burn out my instrument that has a millionth of the smallest mass used in the instruments of others.

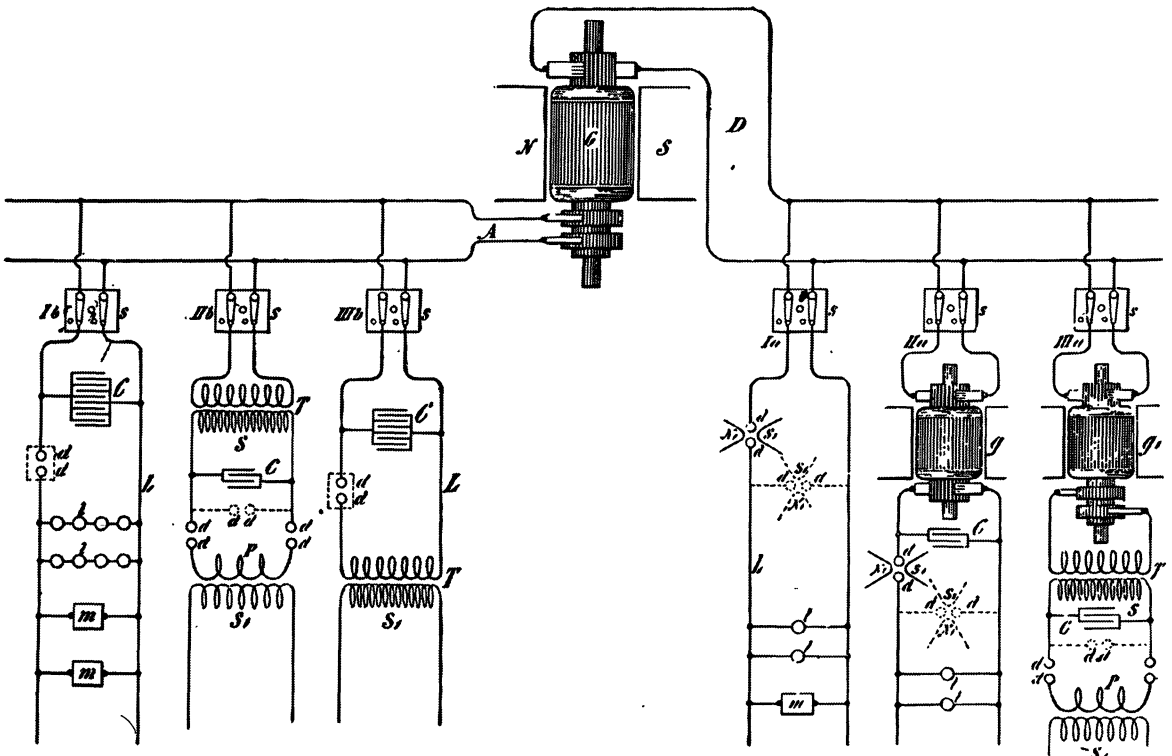

FIG. 165.

Figure 40.

Apparatus and method of conversion by condenser discharges applicable to both alternating and direct currents. Described in lectures before the Franklin Institute and the National Electric Light Association early in 1893. Illustrated in Martin book, Fig. 165, pp. 302-317.

This [Fig. 40] is a systematic representation of the various ways which I gave in my lecture before the Franklin

Institute and the National Electric Light Association, embodying the general arrangements for the obtainment of continuous waves, undamped or damped waves, from direct and alternating current supply. On the one side [right] you have direct, on the other side alternating current supply. Some electricians have had difficulties in operating some of this apparatus. I had none. I can take an ordinary circuit of 50 volts and produce from it absolutely undamped oscillations and never have the slightest difficulty about it.

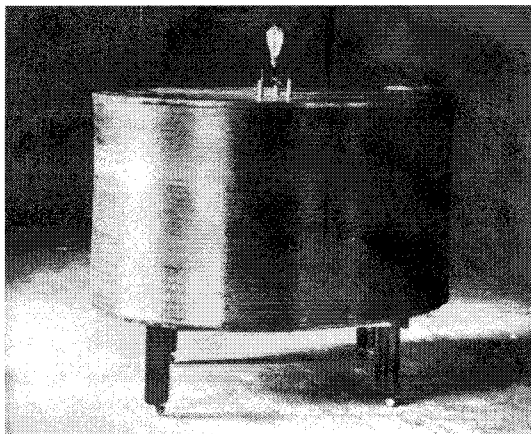

Figure 41.
Illustrating one of the early experiments with a tuned transformer in the laboratory at 35 So. Fifth Avenue.

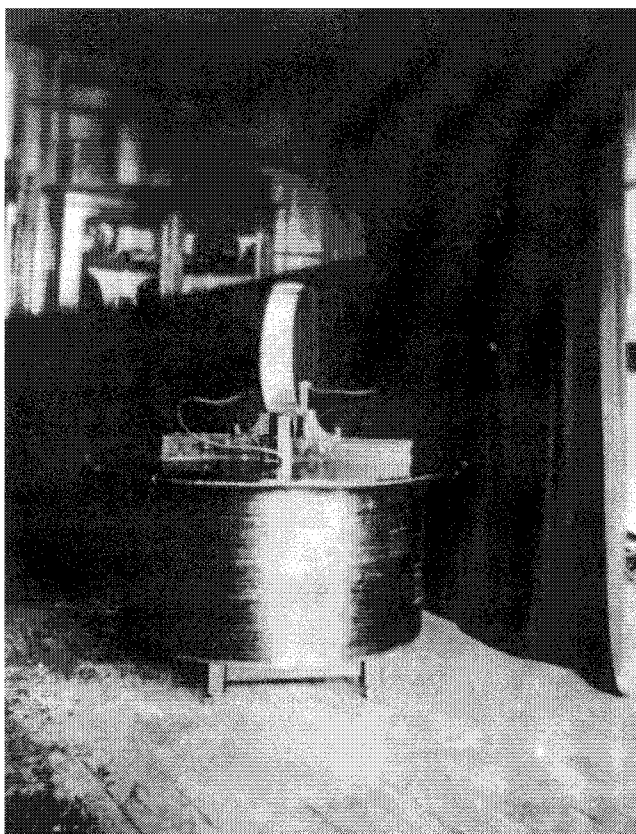

Figure 42.
Another experiment illustrating one of the early experiments with a tuned transformer in the laboratory at 35 So. Fifth Avenue. (Article by Martin ["Tesla's Oscillator and Other Inventions"], Century Magazine, April 1895, Fig. 9, p. 926.)

Now I come to a few pieces of apparatus which I used in the Houston Street laboratory and the South Fifth Avenue laboratory. I have here [Fig. 41] what you might call a tuning coil. I employed usually another secondary and had my condensers on the table. You see one of the coils in action. This is a tuned circuit which responds to electromagnetic waves which are sent through the room.

Counsel

This is being used as a receiver of waves?

Tesla

Yes.

This [instrument shown in Fig. 42] was used in the laboratory on South Fifth Avenue. Here [large circular disc positioned on top of coil] is the tuning table with the condensers, a thick primary, and another secondary wire. Sometimes I would operate with two vibrations and I would tune the first circuit to one and the second to the other. Here [referring to cabinets in back of room] you see some of my historical apparatus. Professor Fairfield Osborn[*] came once to my laboratory and said to me, "Why on earth do you keep it in this laboratory?" I had all of this apparatus, 400 pieces, absolutely priceless, and he offered to take it over to the Museum. But I did not heed his advice, and it is gone.

* Editorial note: H(enry) Fairfield Osborn, Dean, Faculty of Pure Science, Columbia College in the City of New York. Osborn wrote to College President Seth Low in January, 1894, saying in part, "I have especially upon my mind two matters which I think will appeal to you very strongly. The first is connected with Mr. Hill of Nyack, and the second with Mr. Tesla of New York. I have learned recently that Mr. Hill is considered the leading mathematician in this country, and there seems to be little doubt that Mr. Tesla is the leading electrician. They both are in a measure connected with Columbia through Mr. Hill's lectures here, and through the fact that Mr. Tesla at Professor Pupin's and Professor Crocker's invitation gave his first electrical lecture in Columbia. So that we have already established a sympathetic relation with these great men. I spent an afternoon recently with Tesla, and regard him as one of the most distinguished men I have ever met. I happened to meet Professor Crocker shortly afterwards, and learned from him that he had spoken to you in regard to giving Tesla an Honorary Degree. I would like to support this in the most earnest manner. Poulton [Prof. of Biology at Oxford] tells me that Tesla was covered with honors while in England and France. We certainly must not allow any other University to anticipate us in honoring a man who lives under our very walls." In response to this, President Low recommended, in a letter dated February 5, 1894, to the Trustees, that the honorary degree of LL.D. should be conferred on Tesla. The degree was awarded in June, 1894.

Counsel

Where were the waves sent from?

Tesla

The whole room was energized by electromagnetic waves and the receiver responded at any place in the hall. The hall was bigger than this room [shown in Fig. 42], twice as long, and anywhere the intensity of action was the same. These discs [vertical, on top of tuning table] were, I think, about 14 or 15 inches in diameter, and you could see the streamers [shown as white between the discs] anywhere in the room. In a hall twice as long as this, wherever I placed the instrument, it would respond to the electromagnetic waves.

Counsel

In this particular instance you are speaking of, the waves were generated right there at 35 South Fifth Avenue?

Tesla

Yes.

Counsel

Was that the apparatus in which you had the primaries running entirely around the room?

Tesla

Yes. This was shown to many people and societies.

This [Fig. 43] shows the first single step I made toward the evolution of an apparatus which, given primary oscillations, will transform them into oscillations capable of penetrating the medium. That experiment, which was marvelous at the time it was performed, was shown for the first time in 1894. I remember the incident perfectly. I called Mr. Edward Adams, the banker, to come and see it, and he was the first man to observe it and to hear my explanation of what it meant.

This coil, which I have subsequently shown in my patents Nos. 645,576 and 649,621, in the form of a spiral, was, as you see, [earlier] in the form of a cone. The idea was to put the coil, with reference to the primary, in an inductive connection which was not close -- we call it now a loose coupling -- but free to permit a great resonant rise. That was the first single step, as I say, toward the evolution of an invention which I have called my "magnifying transmitter." That means, a circuit connected to ground and to the antenna, of a tremendous electromagnetic momentum and small damping factor, with

all the conditions so determined that an immense accumulation of electrical energy can take place.

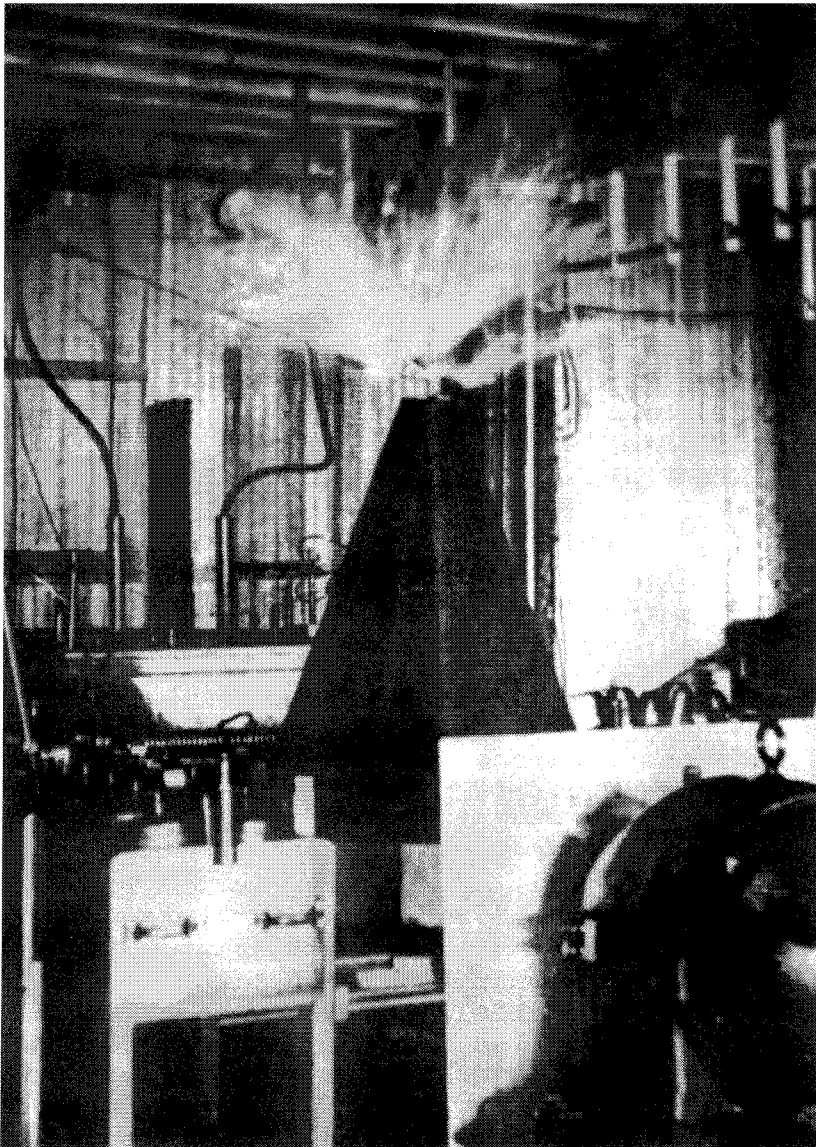

Figure 43.

Apparatus in action illustrating the first step in the evolution of the magnifying transmitter in the laboratory at 35 So. Fifth Avenue. (Article by Martin ["Tesla's Oscillator and Other Inventions"], Century Magazine, April 1895, Fig. 15, p. 932.)

It was along this line that I finally arrived at the results described in my article in the Century Magazine of June 1900. [Fig. 43] shows an alternator; not the alternator that was furnished for my laboratory on Houston Street -- that was another one, [but] at 35 South Fifth Avenue [and] operated on the same principle. Here [lower left] are the condensers,

primary, and all the rest. The discharge there was 5 or 6 feet, comparatively small to what I subsequently obtained. I have produced discharges of 100 feet, and could produce some of 1,000 feet if necessary, with the greatest facility.

Counsel

Mr. Tesla, at that point, what did you mean by electromagnetic momentum?

Tesla

I mean that you have to have in the circuit, inertia. You have to have a large self-inductance in order that you may accomplish two things: First, a comparatively low frequency, which will reduce the radiation of the electromagnetic waves to a comparatively small value, and second, a great resonant effect. That is not possible in an antenna, for instance, of large capacity and small self-inductance. A large capacity and small self-inductance is the poorest kind of circuit which can be constructed; it gives a very small resonant effect. That was the reason why in my experiments in Colorado the energies were 1,000 times greater than in the present antennae.

Counsel

You say the energy was 1,000 times greater. Do you mean that the voltage was increased, or the current, or both?

Tesla

Yes [both]. To be more explicit, I take a very large self-inductance and a comparatively small capacity, which I have constructed in a certain way so that the electricity cannot leak out. I thus obtain a low frequency; but, as you know, the electromagnetic radiation is proportionate to the square root of the capacity divided by the self-induction. I do not permit the energy to go out; I accumulate in that circuit a tremendous energy. When the high potential is attained, if I want to give off electromagnetic waves, I do so, but I prefer to reduce those waves in quantity and pass a current into the earth, because electromagnetic wave energy is not recoverable while that [earth] current is entirely recoverable, being the energy stored in an elastic system.

Counsel

What elastic system do you refer to?

Tesla

I mean this: If you pass a current into a circuit with

large self-induction, and no radiation takes place, and you have a low resistance, there is no possibility of this energy getting out into space; therefore, the impressed impulses accumulate.

Counsel

Let's see if I understand this correctly. If you have radiation or electromagnetic waves going from your system, the energy is wasted?

Tesla

Absolutely wasted. From my circuit you can get either electromagnetic waves, 90 percent of electromagnetic waves if you like, and 10 percent in the current energy that passes through the earth. Or, you can reverse the process and get 10 percent of the energy in electromagnetic waves and 90 percent in energy of the current that passes through the earth.

It is just like this: I have invented a knife. The knife can cut with the sharp edge. I tell the man who applies my invention, you must cut with the sharp edge. I know perfectly well you can cut butter with the blunt edge, but my knife is not intended for this. You must not make the antenna give off 90 percent in electromagnetic and 10 percent in current waves, because the electromagnetic waves are lost by the time you are a few arcs around the planet, while the current travels to the uttermost distance of the globe and can be recovered.

This view, by the way, is now confirmed. Note, for instance, the mathematical treatise of Sommerfeld, [*] who shows that my theory is correct, that I was right in my explanations of the phenomena, and that the profession was completely misled. This is the reason why these followers of mine in high frequency currents have made a mistake. They wanted to make high frequency alternators of 200,000 cycles with the idea that they would produce electromagnetic waves, 90 percent in electromagnetic waves and the rest in current energy. I only used low alternations, and I produced 90 percent in current energy and only 10 percent in electromagnetic waves, which are wasted, and that is why I got my results.

* Editorial note: Sommerfeld, Arnold N., "Über die Ausbreitung der Wellen in der drahtlosen Telegraphie," Annalen der Physik, March 16, 1909 (Vol. 28, No. 4), pp. 665-736.

**V. Apparatus for Transformation by Condenser Discharges;
Continuous Waves**

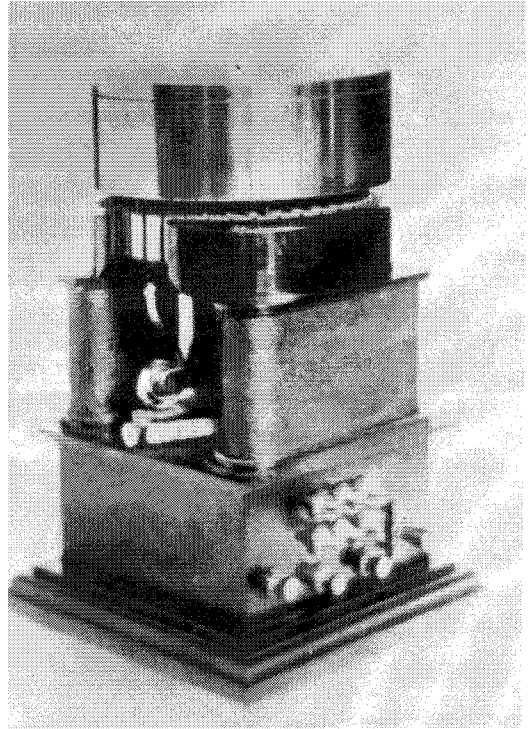

Figure 44.
One of the many forms of
mercury circuit controllers
described in various U.S.
Patents.

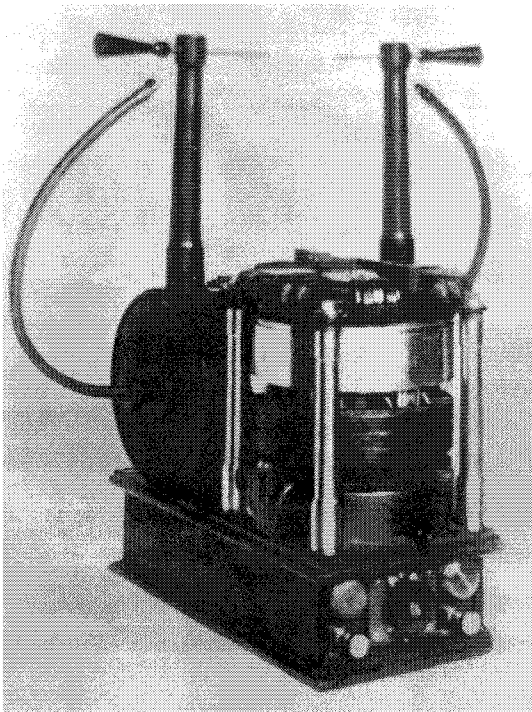

Figure 45.
Hermetically enclosed mercury
circuit controller with com-
pact oscillatory transformer.
Described in U.S. Patent No.
609,245 of August 16, 1898.

Figure 44 (verso).

One of the many forms of mercury circuit controllers. Described in U.S. Patent Nos.:

| | | | | | | | | |
|---------|------------|------|-------|-------------------|----------|----------|------|-------|
| 609,245 | of August | 16, | 1898, | application filed | December | 2, | 1897 | |
| 609,246 | " " | ", " | , | " " | February | 28, | 1898 | |
| 609,247 | " " | ", " | , | " " | March | 12, | " | |
| 609,248 | " " | ", " | , | " " | " | " | " | |
| 609,249 | " " | ", " | , | " " | " | " | " | |
| 609,251 | " " | ", " | , | " " | June | 3, | 1897 | |
| 611,719 | " October | 4, | " | , | " | December | 10, | 1897 |
| 613,735 | " November | 8, | " | , | " | April | 19, | 1898. |

Tesla

This [Fig. 44] shows a further development in the direction of perfecting a way of making and breaking the current, and illustrates one of the simplest forms of my apparatus, which was specially built with a mercury interrupter inside, capable of considerable frequency. That was operated from an ordinary circuit of supply and could stand a current of 20 or 25 amperes. It was a very compact instrument. I had dozens of these instruments, and obtained eight patents on the same; they were all issued in 1898.

The next thing I did was to enclose the mercury break hermetically [Fig. 45]. You see, here [Fig. 46, overleaf] is a motor, especially designed, rotating this pulley.

In this pulley [referring to the cross-sectional diagram] is produced a jet of mercury, and there are teeth running around which make and break the current. The whole is encased hermetically. Here I have a German-silver cup that is nickel plated on the inside, and there is a field magnet outside which holds the mercury jet stationary while the pulley rotates. I could get with this instrument about 2,000 cycles very nicely, and it was a machine that would give an output of about 1 kilowatt. It was a fairly efficient instrument, perhaps 80 percent of the energy of the circuit was obtained in the secondary.

Here [Fig. 47] I come to another device. That was another solution of the problem of producing currents of very high frequency. An alternator was difficult to construct; if one went into too high frequencies, it became inefficient and worthless. But, in this way, I was able to get any frequency up to 200,000 per second, or more, in a perfectly reliable manner, and I could get a couple of kilowatts output very easily.[*] That was especially built for telegraphy, telephony, and similar experiments.

* Editorial note: In the article, "Dr. Nikola Tesla and His Achievements" by Samuel Cohen, appearing in the Electrical Experimenter magazine, February 1917 (pp. 712, 713, 777), figure 4 shows an interrupter having a similar external appearance and it is described as handling 50 horsepower (37 kilowatts).

No. 609,245.

Patented Aug. 16, 1898.

N. TESLA.

ELECTRICAL CIRCUIT CONTROLLER.

(Application filed Dec. 9, 1897.)

(No Model.)

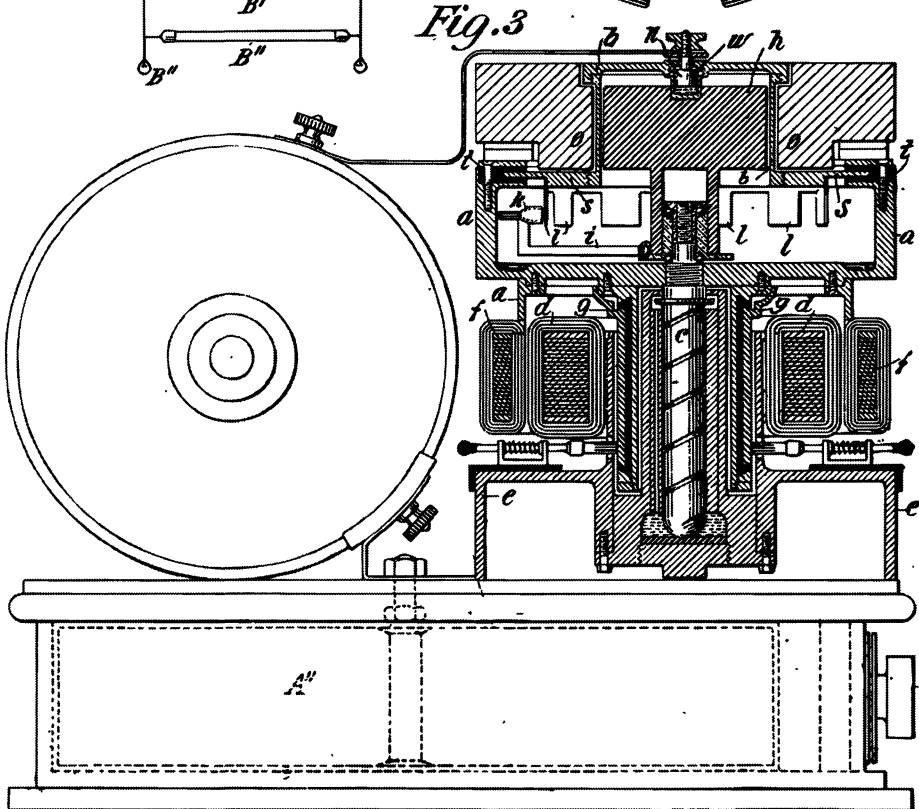
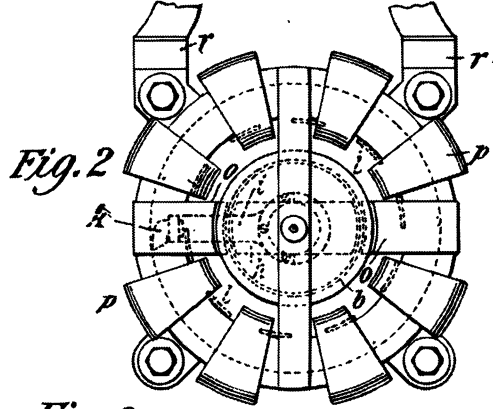
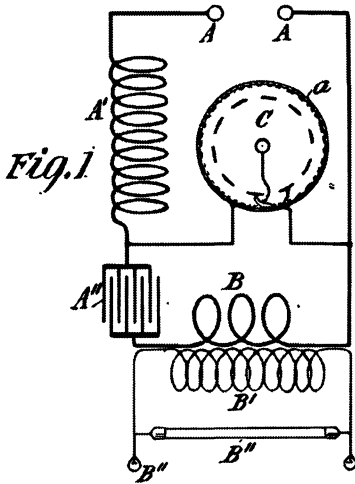

Witnesses:
Raphael Vetter
M. Lamou & Co.

Nikola Tesla, Inventor
by Kerr, Curtis & Sage Attys

Figure 46.
 Diagrammatic illustrations of hermetically enclosed mercury break described in U.S. Patent No. 609,245 of August 16, 1898.

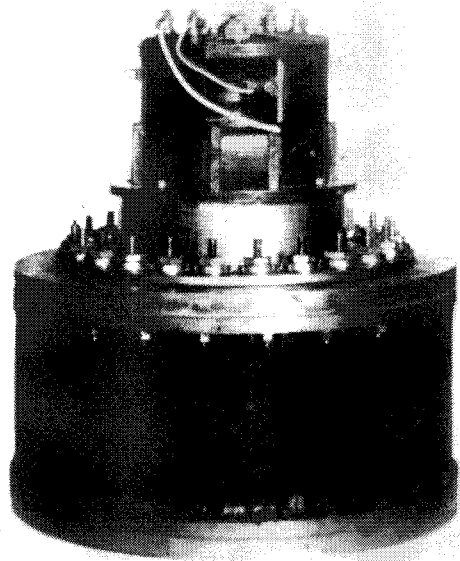

Figure 47.
Large mercury circuit controller of high frequency (telegraphic and telephonic experiments).

The arrangement was simply this. I had a number of studs with cups which were insulated, 24 if I recollect rightly. In the interior was a mechanism that lifted the mercury, threw it into these cups, and from these studs there were thus 24 little streamlets of mercury going out.[*] In the meantime, the same motor drove a system with 25 contact points, so that for each revolution I got a product of 24 times 25 impulses, and when I passed these impulses through a primary, and excited with it a secondary, I got in the latter complete waves of that frequency.

Counsel

What frequency, then, did you get in your secondary?

Tesla

Oh, I could get in this, 600 per revolution.

Counsel

You mean 600 trains?

Tesla

No, 600 waves. Assume then, 600 impulses per revolution and suppose that I rotated it 100 times per second [6,000 RPM]; then I would get 600 times 100, or 60,000 primary

* Editorial note: This controller mechanism is described in Tesla U.S. Patent No. 611,719.

impulses [per second], and in the secondary a frequency of 60,000 complete cycles. The primary impulses were unidirectional. They came from the direct current source, but in the secondary they were alternating -- full waves.

Counsel

How persistent were those waves?

Tesla

They were entirely persistent. I had 60,000 per second absolutely undamped waves; they could not be damped.

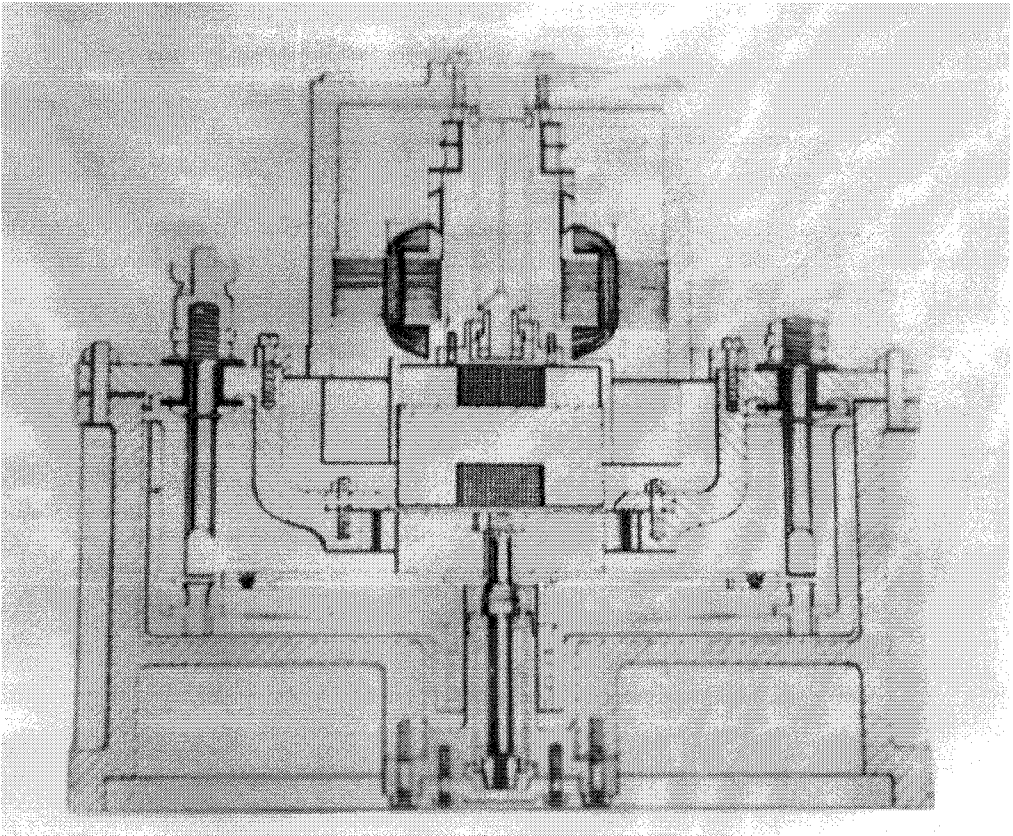

Figure 48.

Drawing -- Interior arrangement of large mercury circuit controller of very high frequency. (1899)

I want to show you [Fig. 48] the general arrangement in such an instrument, except that this does not exactly illustrate the interior of the other one [Fig. 47]. But, you can readily see a pump that takes the mercury up, and then the mercury flows out against this stud, and as these arms rotate they break the mercury stream and interrupt the current.

That [Fig. 48] was another type. I had probably 50 or 60 different instruments; in fact, I spent a little fortune on these devices, but some of them have been very valuable, and I do not know but that they will take an important place in the art. They are used very extensively.

The other day, some time ago, a German concern, in recognition of my inventions, made me a present of a very nicely developed interrupter which they had been manufacturing along the lines of my patents. My patents expired; they used the inventions and built up a business, and felt that at least they ought to give me one instrument, and they did. It was very nice.

Counsel

This then, as operated by you, produced undamped waves. Will you tell us just what use you made of it?

Tesla

Oh, I used it just exactly as I used the high frequency alternators. I would energize the primary circuit, and then in the secondary connect the antenna. You see, with an apparatus about 18 inches in diameter, I could get 2 kilowatts in undamped waves.

Counsel

When was this?

Tesla

These instruments all were made, practically all -- I had perhaps 40 or 50 of them -- prior to 1899. When I came to my plant on Long Island, I did some further work on them, but I used the old casings and simply changed the interior construction.

There was one construction I had, a very fine thing in which I did not produce any streams. It was so devised that the mercury filled these pockets, and I had 24 little droplets coming out of these places. Then, on the other hand, I had curved arms running around and forcing mercury out under small pressure due to a difference in the length of two columns in the curved arm. I had just the drops meeting, and there was no mercury flowing out in reality. There was simply mercury touching mercury, the contacts being at a distance of about 1/64 inch. These devices worked very well indeed. I have this little instrument from Germany -- of course the Germans do everything so thoroughly -- it is very reliable. I can pass through it regularly 20 amperes, and it works well -- no trouble at all. This [Fig. 48] is a little bit different in

construction but, as I say, my patents described many forms. I have spent a lot of gray matter in developing these instruments.

This [Fig. 49] I must show you, because that was a transformer of the high frequency type which I used. I could not employ ordinary transformers, and I built something special. I had my primary on the outside, and inside was the secondary. That enabled me to use thick wires in the two circuits and put them in a loose inductive connection. I had two of these transformers. They were made late in 1896, and I remember that with one of these transformers I showed experiments to Lord Kelvin. He was interested in this form of transformer and I explained to him why I departed from the usual arrangement. That instrument was simply one of the accessories in the equipment of my plant.

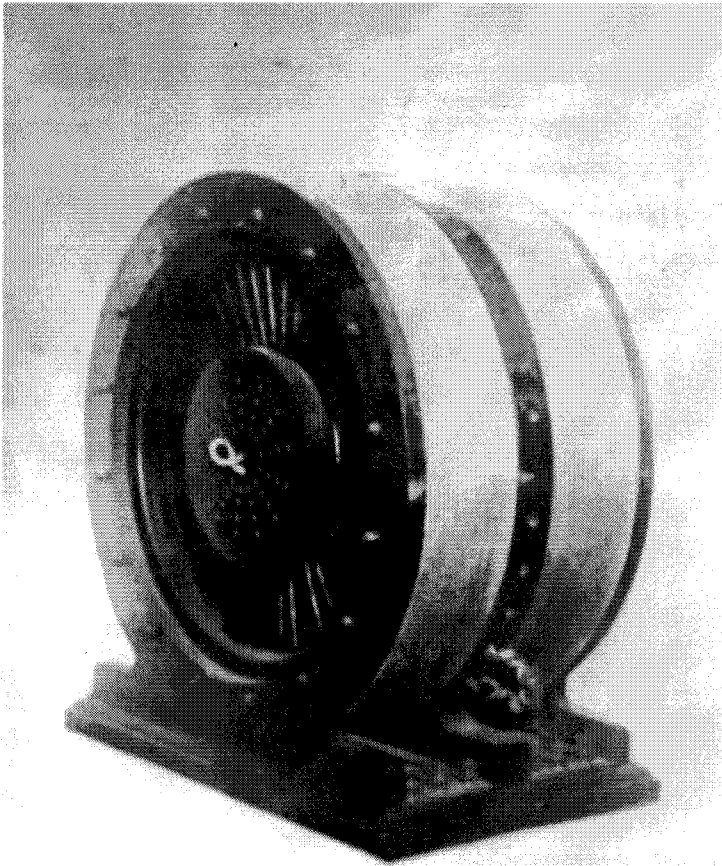

Figure 49.

Special type of high frequency transformer. Houston Street laboratory; later in Colorado. Tesla article, "The Transmission of Electric Energy Without Wires," Electrical World and Engineer, March 5, 1904, pp. 429-431. Made in 1896.

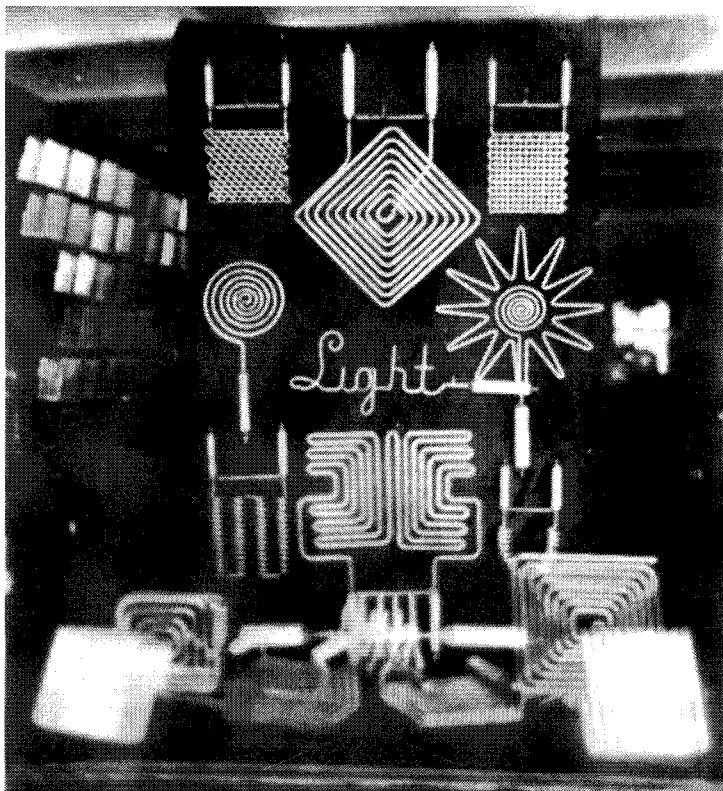

Figure 50.
Illustrating forms of vacuum tubes.

This [Fig. 50] does not refer to wireless telegraphy, but it does refer to wireless transmission of energy. These [upper] are forms of tubes I used, and these [on table] are the forms that I proposed to use in a larger plant when transmitting energy. This is, in fact, the ideal application of the transmission of wireless energy because the lighting can be effected in isolated places at a much smaller cost than is possible by any other method known. I also believe that nowhere as yet has a source of illumination been produced, neither the tungsten or the mercury arc nor anything else, which has the efficiency in light production that my tubes have; but they can only be used to produce light on a large scale, and that project, unfortunately, has not yet been carried out; but I think it will.

This [Fig. 51] is the transmitter which was already so far developed that I obtained discharges of 16 feet and a tension of 4 million volts. The secondary [flat spiral] usually connects to the antenna, and this [coil on vertical stand] is another tuning coil to adjust the oscillations to a low frequency. Now, it is a mere matter of proportioning this circuit to the antenna in order to transmit, with the same apparatus I built in 1895, 1896, and 1897, messages across the Atlantic with the greatest facility. I will agree at any time

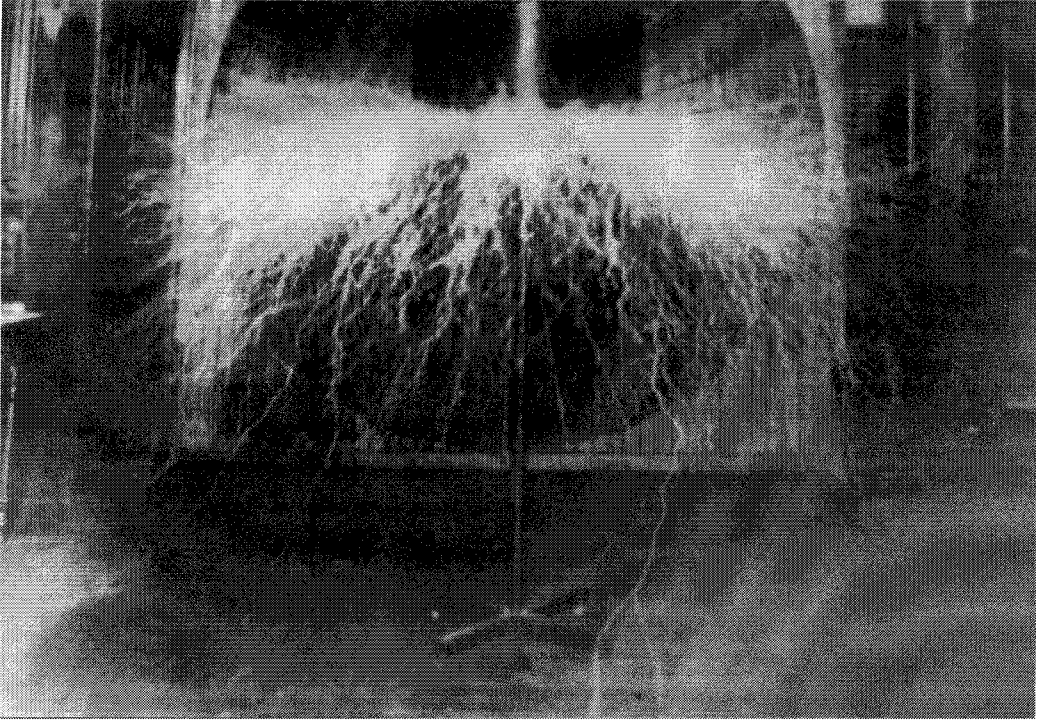

Figure 51.

Resonant wireless transmitting circuit. (Described in *Electrical Review*, New York, March 29, 1899, pp. 193-197, 204, and *Electrical Review*, London, May 5, 1899, pp. 730-733.)

to construct an apparatus exactly as I have described at that time and, without the slightest change, I will effect transmission across the Atlantic as easily as rolling off a log.

Counsel

Is that a spark apparatus?

Tesla

Yes, in this instance it was a spark apparatus; but I operated it also without a spark, with alternating current. I operated it with damped waves or with undamped waves. But remember that I had a system with small capacity, large self-induction -- no outflow of energy. Energy could not radiate; that is the reason why I got this tremendous pressure which you cannot get in an antenna which radiates too much energy in electromagnetic waves.

Counsel

Mr. Tesla, speaking about that apparatus you said that the energy could not get out. How was the transmission then made, as for instance, across the Atlantic, or elsewhere? Is it through these earth currents that you spoke of?

Tesla

Yes, of course, through the earth currents. If I simply generated electromagnetic waves, I would be in the same box that Marconi is in, or anybody else; I would have to use an awful lot of power and I would not be able to get across. I would have to use a bigger apparatus. But, if I adapt this apparatus to the antenna in the way I want to adapt it, there is no difficulty of transmitting across the Atlantic with this very same apparatus.

I understand that the Atlantic Communication Company made recently, in a suit, an experiment -- I believe Pickard [*] told me about it -- [where] they constructed a coil according to my inventions, and then they telegraphed -- I don't know, 200, 300, or 400 miles. When Pickard told me about that, I saw that they did not make the test properly. You see, they should have obtained the low frequency by using more primary energy, by adding more condensers, but they did not do that; they only used the capacity which I specified in my patent, which was only, I understand, 0.04 microfarad. They should have added to the condenser [additional] capacity and got down to a lower frequency with a bigger inductance; then they could have telegraphed across the Atlantic. Why not? The same apparatus is used in all of these plants. These stations, every one of them, have adopted the spiral form. [See Appendix I, Fig. 2.]

Counsel

Pickard did not understand your disclosures, then, did he?

Tesla

Excuse me, he understood them perfectly.

Counsel

But he did not embody them in the apparatus?

Tesla

He did not do the thing as I would have done it, I will admit that; but, then, there are artists, and then there are others.

* Editorial note: Greenleaf Whittier Pickard, grandnephew of poet John Greenleaf Whittier. Beginning in 1903, he investigated using minerals as detectors and is identified with introducing the "crystal" detector. At the time of this interview, he was a research engineer and designer with the Wireless Specialty Apparatus Company.

Counsel

I do not yet get quite clear just what the effect is of keeping the energy from leaking out from the antenna.

Tesla

Well, sir, I have given you the simplest mathematical formula which, of course, experts are perfectly familiar with. You are not. Now, let me explain.

If we put it in an equation, we will have on one side the decrement of the antenna, and on the other the resistance of the antenna multiplied by the square root of the capacity divided by the self-induction.[*]

Counsel

Yes, I understand. I have heard of that formula; but I do not understand how transmission is effected unless there is radiation.

Tesla

This is a very important thing. We will come to that; I will explain it later.

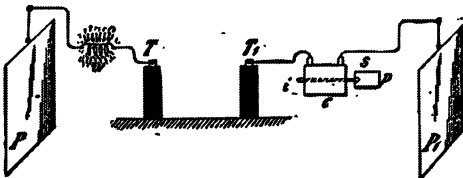

FIG. 175.

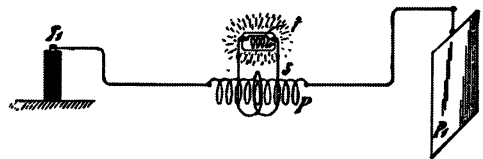

FIG. 176.

Figure 52.

Experiments illustrating transmission and transformation of energy through one wire made in demonstrations before the Franklin Institute and the National Electric Light Association in 1893. Illustrations from Martin book, Figs. 175 and 176, pp. 328, 329.

Here [Fig. 52] are illustrated the first experiments I demonstrated in public, in my lectures in the United States, forming the original striking departures -- the first primary steps I made in operating devices, when I showed this new principle of conversion. I passed a current of high tension through one wire, then I reduced the pressure in a secondary; that is now a very common practice.

* Editorial note: See, for example, Zenneck, Jonathan, Wireless Telegraphy, McGraw-Hill, 1915, p. 165.

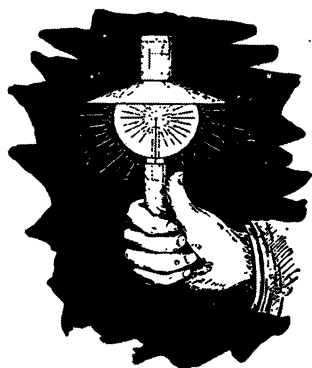

FIG. 190.



FIG. 191.



FIG. 192.

Figure 53.

Some of the most striking experiments with vacuum tubes and lamps shown before the Franklin Institute and the National Electric Light Association in 1893. Martin book, Figs. 190, 191, and 192, pp. 358, 359.

These were the most striking results I showed in the transmission of energy in my lectures before mentioned. You see how far I have gone into the mastery of electrical vibrations in 1893. I stand here [Martin's Fig. 190] in the hall, holding a lamp in my hand, and the energy transmitted lights it. Here again [Fig. 191] I hold a phosphorescent bulb in my hand, and here [Fig. 192] a vacuum tube.

These experiments, I remember, were made in St. Louis. There was a hall with 6,000 or 7,000 people. When I explained how I had shown a phosphorescent bulb to Lord Kelvin in England, and told them that the bulb was going to spring into light, and the current was turned on and it did burst into light, there was a stampede in the two upper galleries and they all rushed out. They thought it was some part of the devil's work, and ran out. That was the way my experiments were received.

VI. Colorado Experiments

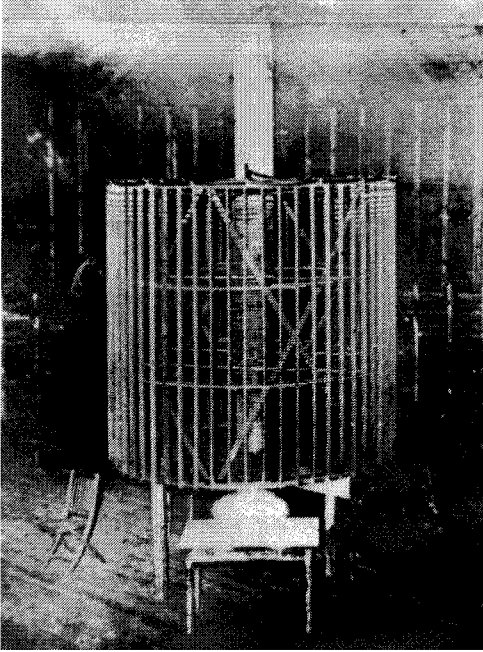

Figure 54 (left).
Experiment showing the lighting of incandescent lamps by energy transmitted through one wire with more powerful apparatus.

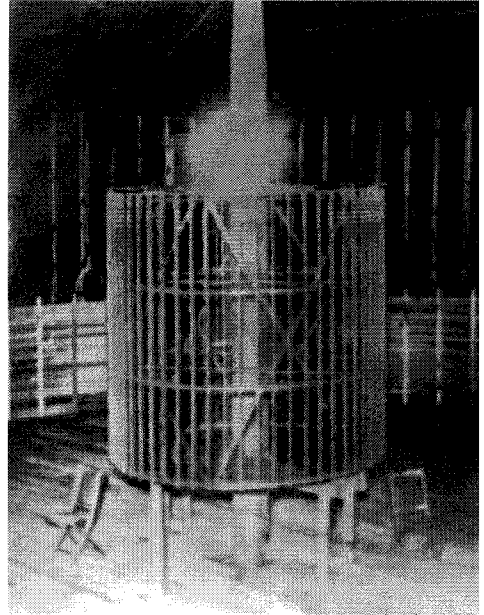

Figure 55 (right).
Still more striking experiment with the same apparatus in which a lamp is lighted at the extreme end of a coil. (Article "The Problem of Increasing Human Energy," Century Magazine, June 1900, Fig. 3, p. 186.)

Tesla

Here [Fig. 54] I show that I have advanced further, much further. This is an experiment in Colorado [*], and as you see, five or six lamps are lighted -- no capacity, just simply a coil into which the current passes. I have not the time to do justice to these photographs now.

This [Fig. 55] is a wonderful result, showing a further perfection. To give an idea of the power of all these oscillations, I put a lamp on the end of a coil, nothing else, and it is lighted to full brilliance just by reason of the fact that it has a minute capacity, only 4 or 5 centimeters [4.4 or 5.5 picofarads]; that is enough to light it.

* Editorial note: For comments on the Colorado experiments appearing in earlier sections, see pp. 32, 61, 62, 74, and 82 (Fig. 49 caption); in later sections, see pp. 130, 137, 145, 146, 163, 167, 170, 172-175, and 179.

Counsel

Where is the other coil?

Tesla

You see it [in the background of] this picture. The coil here is 51 feet in diameter.

Counsel

A wire around the room?

Tesla

No, it is a coil. That [in the picture background] is my secondary. That is the coil which connects to the antenna, you see. But this smaller coil stands free, entirely free, in the center of the big one.

Counsel

Is this apparatus shown here the receiver; that is, is the glow that we see there the indication of received energy?

Tesla

Yes, but that is the energy supplied through one wire. That is, I am now describing various effects. I meant to lead up from the transmission over one [wire] to the transmission

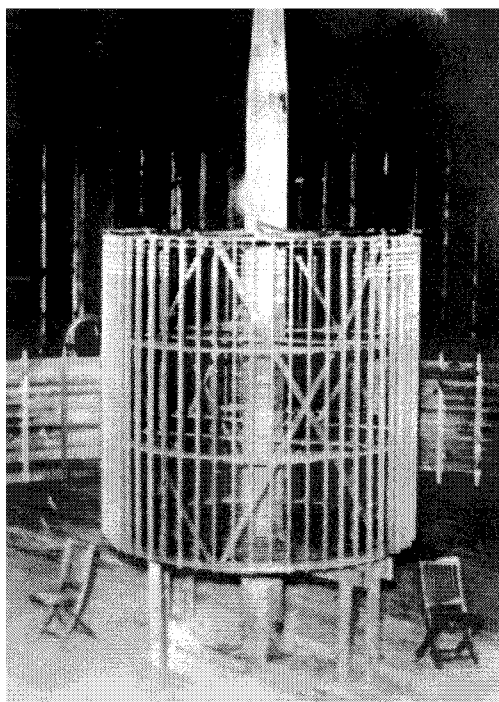

Figure 56.

Illustrating another experiment with the same apparatus in which the coil is not directly connected to the source of oscillations, but receives the effect inductively from a distance. [Note: the wire lead used to connect the resonator to the ground plate is absent.]

through the earth. This is transmission through one wire, but shows what a marvelous oscillation takes place in the circuit when one can light a lamp at the end without any capacity, just a bulb.

I measured the capacity of the bulb. The capacity was 2 or 3 centimeters [2.2 - 3.3 picofarads], at most, and in order to light a lamp with a capacity of 2 or 3 centimeters, you can appreciate what a tremendous vibration that must have been.

This [Fig. 56] is another experiment, another effect. Here is a coil absolutely disconnected from everything else. I transmit electromagnetic energy to it. There is a lamp at the end and that lamp lights. There is no connection to the coil whatever.

Counsel

And from what source does that coil get its energy?

Tesla

From a [primary] circuit that is 51 feet in diameter, and goes all around. Some of these experiments have been described in my article in the Century Magazine, June 1900.

This [Fig. 57] shows the general arrangement of the apparatus. That [middle upper-left], you see here, is a coil 51 feet in diameter; it is my secondary. That is not a thin wire; it is a very thick cable. It is a coil about 9 feet high. This wire goes up to the antenna. Here [lower half] are my condensers, and the transformers behind. There is my self-inductance [with wooden-handle crank], and all the rest.

Now you see [in Fig. 58] another thing. I have a number of coils here. Notice the coil in the center. These are coils which I have tuned to various frequencies; that is, to harmonics. They receive electromagnetic energy by induction, and you see the enormous discharge from the center coil, although it is unconnected and at a distance of many feet from the primary.

Counsel

Were those spark generators?

Tesla

I used the spark method and continuous, or undamped, oscillations. I had for their generation ordinary current of 133 cycles and also a street railway current of 550 or 600 volts, from which I produced undamped waves.

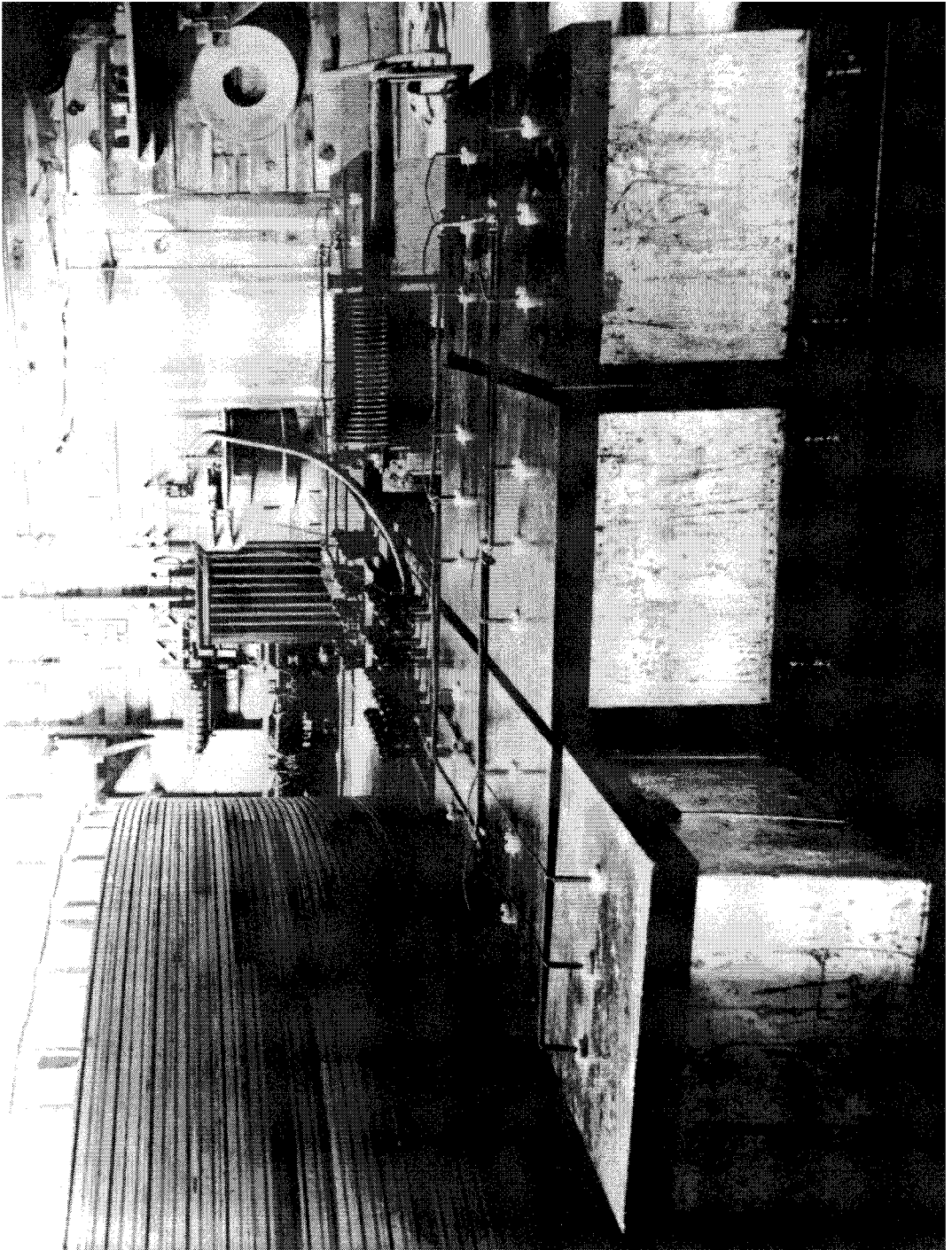

Figure 57.
Oscillating apparatus on large scale with which the preceding experiments were made. Coil at left, 51 feet in diameter, forms part of the magnifying transmitter. (Article, "The Problem of Increasing Human Energy," Century Magazine, June 1900, Fig. 6, p. 188.)

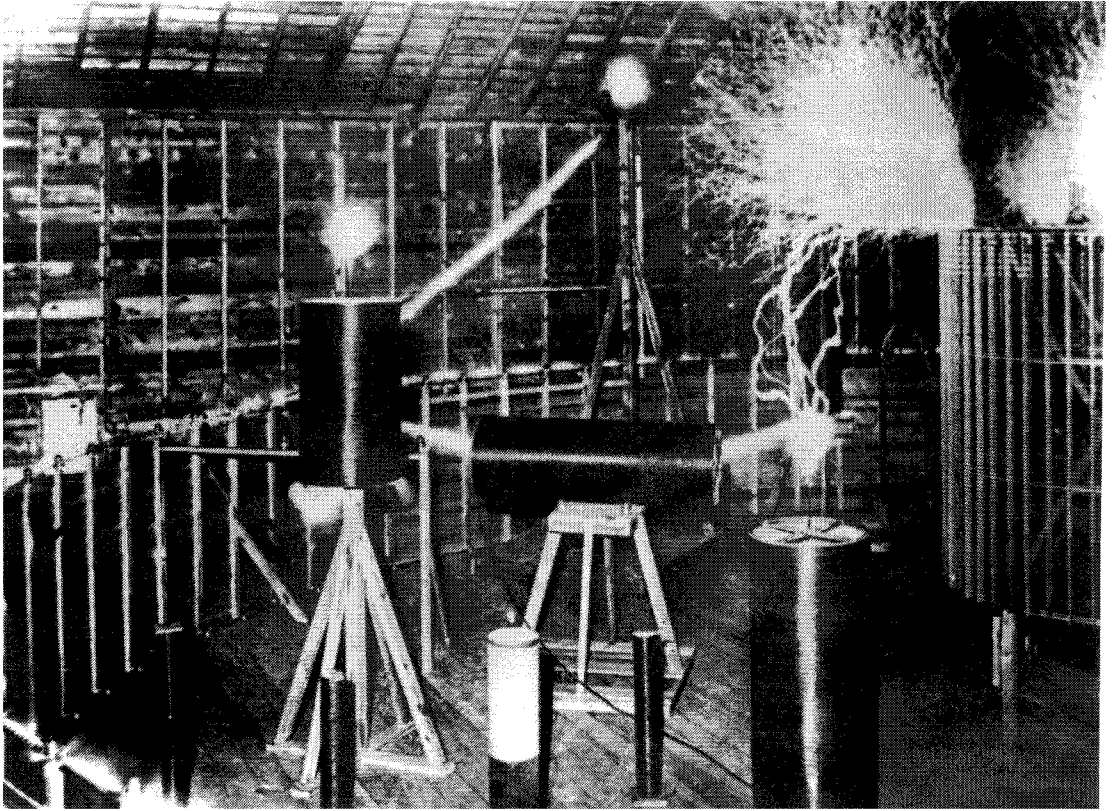

Figure 58.

Experiment with coils tuned to harmonics. (Article, "The Problem of Increasing Human Energy," Century Magazine, June 1900, Fig. 5, p. 187.)

Counsel

And this relates to the experiments that are described in the June 1900 Century Magazine?

Tesla

Yes, those experiments of powerful discharges which I showed you were mostly performed in this way, with a few primary impulses and superimposed quicker vibrations.

Counsel

But they were spark discharges?

Tesla

They were spark discharges because, as I said before, working with damped waves we can produce wonderful effects. Operating with undamped waves, we have to stick to the actual capacity of the machine.

Figure 59.
Transmission of energy with tuned system by induction. (Article, "The Problem of Increasing Human Energy," Century Magazine, June 1900, Fig. 7, p. 189.)



This [shown in Fig. 59] is transmission of energy by induction. Here is a tuned circuit, you see, out in the field with three incandescent lamps and a condenser. The energy is transmitted inductively, from the oscillator. In this case, I have the primary supply circuit, the energizing condenser

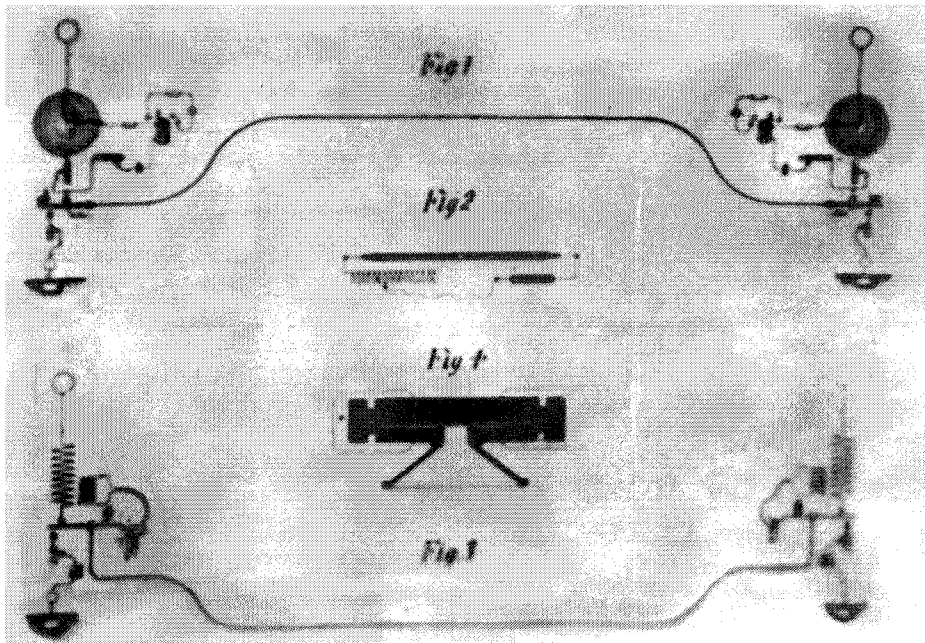

Figure 60.
Application of the one-wire principle to the transmission of telegraphic and telephonic messages. (1896-1897)

circuit, the primary inducing circuit, and the secondary in the field as in the fourth circuit, all tuned -- four circuits in resonance.

Here [Fig. 60], from a drawing for a patent application not pursued, are shown arrangements in single-wire transmission. All of these arrangements date back to 1896, 1897, and 1898.

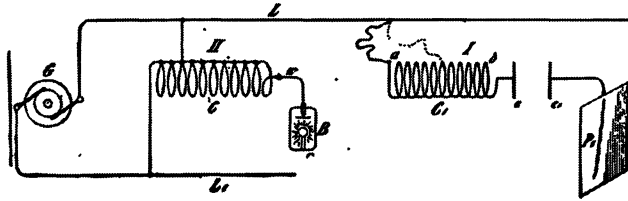

FIG. 184.

Figure 61.

Illustrating experiment with high frequency alternator and tuned circuit having adjustable inductance and capacity as described in lecture before the Franklin Institute and the National Electric Light Association in February and March 1893. Illustrated in Martin book, Fig. 184, p. 344. (See Chapter, "On Electrical Resonance.")

Here [Fig. 61] is a diagram which was published on my lectures before the Franklin Institute and the National Electric Light Association. There I first alliterated and described a complete system of wireless transmission. I show here a generator at one side, a line extending from it, a capacity which is adjustable, as well as an inductance.

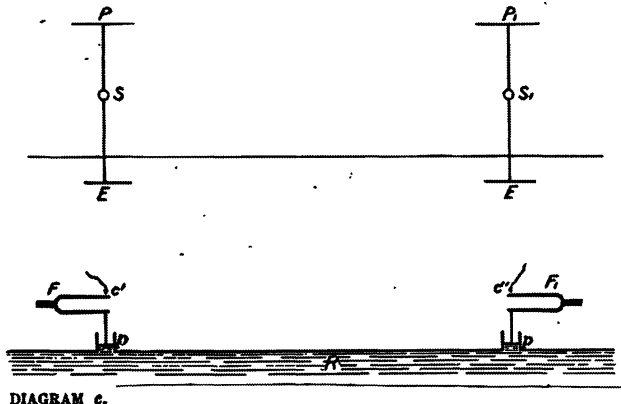

DIAGRAM c.

Figure 62.

Wireless transmission demonstrated, mechanically elucidated, as demonstrated before the Franklin Institute and the National Electric Light Association in February and March 1893. (Article, "The Problem of Increasing Human Energy," Century Magazine, June 1900, Diag. C, p. 206.) Illustrated in Martin book, Fig. 185, p. 348. (See Chapter, "On Electrical Resonance.")

I had, preliminarily to the article in the Century Magazine, to explain, in a popular way, the language of the wireless men; and my friends, R.U. Johnson, and R. Watson Gilder, wanted it explained in the simplest possible manner. This diagram [Fig. 62, top] illustrates the wireless system as I have described it in my lecture and this one, below, its mechanical analogue which I put in for the benefit of the Century Magazine readers.

Figure 63.

Striking experiment in the transmission of energy by electromagnetic waves. Demonstrated in lectures before the Institution of Electrical Engineers and the Royal Institution, London, in February 1892. Illustrated in Martin book, Fig. 164, p. 288.

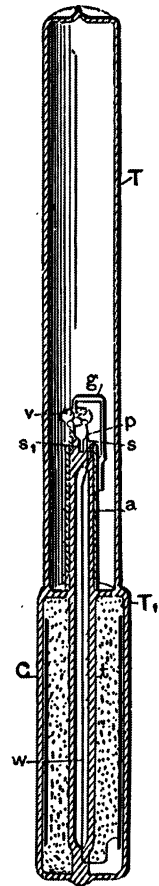

I show two illustrations now. This [Fig. 63], the first one, is to illustrate what I have already partially explained. The experiment was shown before the Institution of Electrical Engineers and the Royal Institution in London in 1892; I will illustrate [next] another experiment which I performed in Colorado in 1899 or 1900. That [Fig. 63] is the time where I take a glass tube, hold it in my hand, with nothing nearby. I create electromagnetic energy in the room, and I operate a little fan in that tube by the electromagnetic waves -- a wonderful thing. The scientists simply did not know where they were when they saw it.

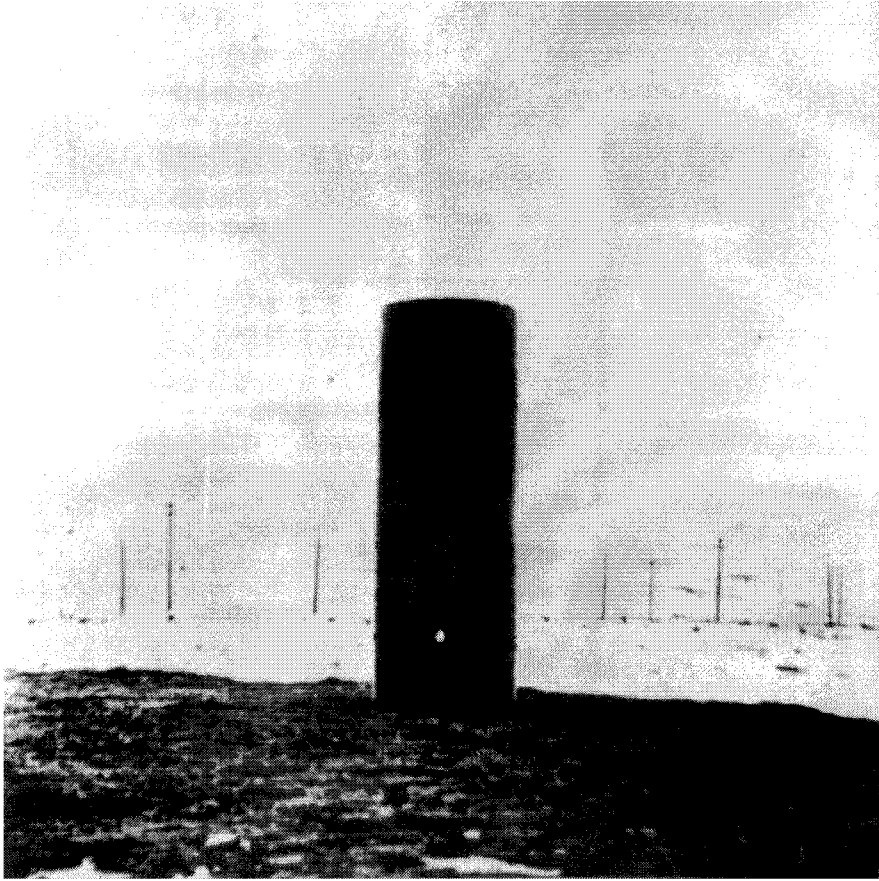

Figure 64.

Another less impressive but infinitely more important experiment in the transmission of energy performed in 1899.

Now I will show you [Fig. 64] the other experiment. How is that experiment performed? Here is a coil, without any antenna, no capacity whatever; just a simple, plain coil. It is placed at a distance from the transmitter and is connected to the ground. I have tuned it so that it forms the fourth circuit of a system of concatenated tuned circuits, and I have another secondary coil here which is likewise tuned, and I light a little lamp. That little lamp is nothing spectacular, nothing that would impress the scientific imagination, but that experiment which I showed you before, while wonderful, was worthless. It never in the world could lead to any development. It was so because of the fact that I employed agencies which were condemned from the very beginning as worthless. But this, here, is a great experiment, marking an epoch in the evolution of the art.

Note that I connect a coil to the ground, impress powerful oscillations on the earth, and draw energy from it. This

coil I can put at the antipodes and, if I have my system properly developed, it makes absolutely no difference whether it is there or 10 feet from my transmitter. That is the difference between the two experiments.

Counsel

When was that last one?

Tesla

That was in Colorado in 1899 -- at the close of 1899, that last experiment. And the other one was in 1892 before the Institution of Electrical Engineers in London.

Counsel

The difference between those two experiments last described was that the first one in 1892 had no grounding?

Tesla

No grounding.

Counsel

In the second, the coil was grounded?

Tesla

In the second the coil was grounded, and the energy was not that of electromagnetic waves, which is wasted; it was the energy of a current through the ground that produced the effect. This transmission was efficient; the other one was worthless.

Counsel

How far was that coil [Fig. 64], in Colorado, from the circuit?

Tesla

That was out in the field. I cannot tell you. The very same experiment was illustrated in the Century Magazine of June 1900 and I know when I wrote it that I gave full particulars.[*]

* Editorial note: Neither the text, nor the caption for Fig. 4, p. 186 of the Century Magazine article of June 1900, carry distance information.

No. 645,576.

Patented Mar. 20, 1900.

N. TESLA.

SYSTEM OF TRANSMISSION OF ELECTRICAL ENERGY.

(Application filed Sept. 2, 1897.)

(No Model.)

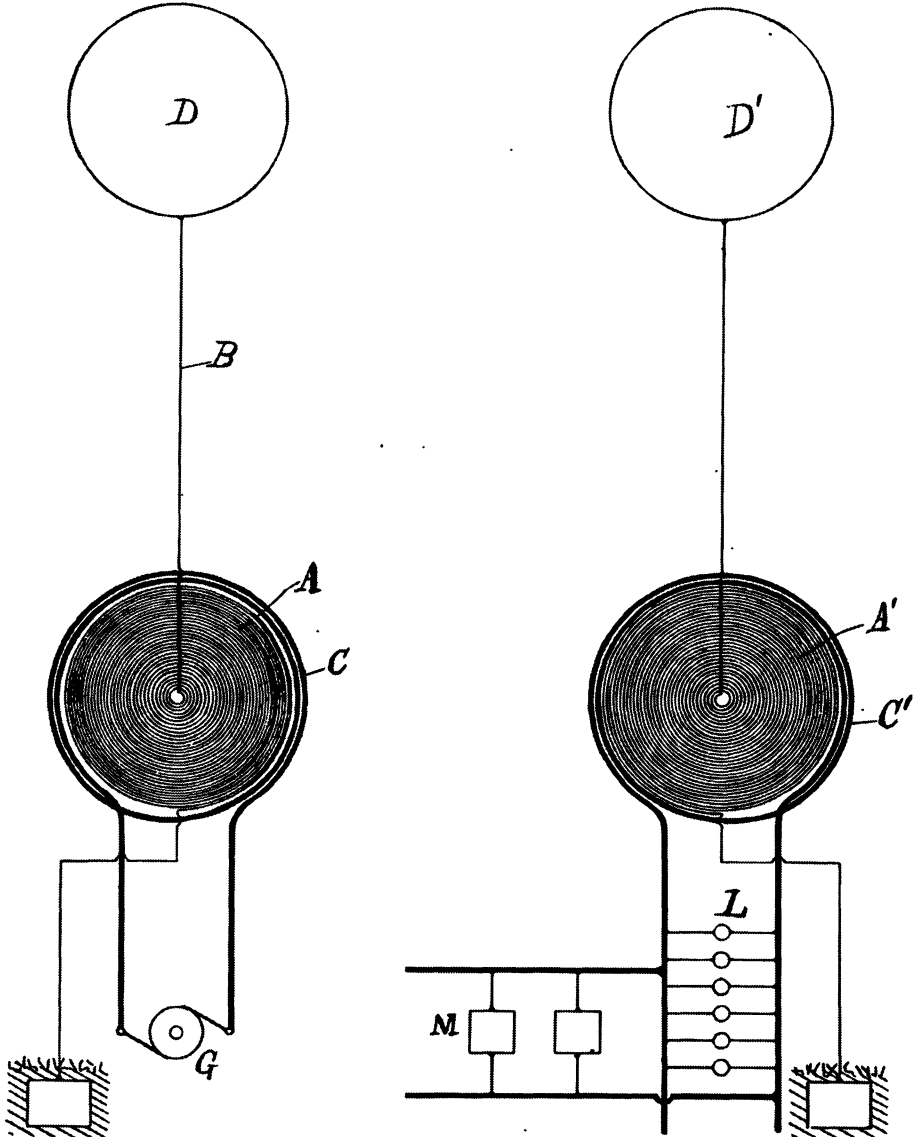

WITNESSES

Dwight N. Cooper
W. Lawson

INVENTOR

Nikola Tesla
 BY
Cur. Curtis & Page
 ATTORNEYS.

Figure 65.
 Perfected system of wireless transmission with four tuned circuits.
 Described in U.S. Patent Nos. 645,576 of March 20, 1900 and 649,621
 of May 15, 1900. Applications filed September 2, 1897.

Here [Fig. 65] is my completed wireless system. That was published first in my Belgium patent in 1898. I clearly remember that the day when I received it I entertained the present King [Albert] in my laboratory [August 1898] and explained to him the system.

There [at left] is my primary source of energy, which produces arbitrary oscillations of any kind. This antenna, you see, is grounded; no break in the connection. These two circuits are tuned to a definite frequency, which was arbitrarily adopted. The dynamo supplies oscillations which have been settled upon beforehand, of low frequency, of course, and the circuit is excited in the manner I have described.

Here [at right] I have the receiving circuit, similarly connected to ground and to an antenna. Then I have a second tuned circuit in which are included the operating devices.

There is an important thing which is not known to engineers, which I want to point out. I have, in the evolution of the whole system, always laid stress that whenever my high frequency currents are employed, no matter how many circuits there are, those circuits are all to be tuned, preferably to the same note.

In one of these patents [i.e., No. 645,576] I described a transmitter giving minutely the dimensions of the coil, of the condenser, and everything in connection with it.

There is one [other] important point. I have insisted on the tuning of all circuits but, you see, often people have maintained that if a certain thing is not done it will not work, and all that. There is no truth in such statements. That circuit, and that, and that one must be attuned; this is an indispensable condition for economic transmission; but it is not essential to tune this fourth circuit. As a matter of fact, in certain instances I have obtained a better result without tuning the fourth circuit than when I tuned it, and I will tell you the reason why. That is not known to engineers.

If you take this fourth circuit [C'] entirely away, and leave only that circuit here, the antenna and the ground connection, then that is the ideal condition for the flow of the current in this receiving circuit. Any other circuit you bring near to that excited circuit with the antenna will draw energy from it and tend to pull down the oscillation in the latter circuit and diminish the resonant rise. No matter what you link to the antenna circuit, and how you link it, the energy you take away from that circuit will always tend, being frictional, to diminish the resonant rise. Now the art consists in reducing as much as possible the energy necessary for the signal, and in that regard the evolution of detectors as

the audion of Dr. De Forest, and of other such devices, is in the proper direction, rational, and good. But the ideal condition requires that you should have here a device which only requires pressure and no current; and once you have a device which does not need any current but merely acts by pressure and has no internal capacity, so that there will be no capacity current in the circuit, then that is the ideal receiver.

There are two ways in which you can operate if you have a receiver of that kind. One is by linking, closely, your working circuit with the primary excited circuit. The other is by linking it loosely, and then working up the pressure by resonance. You will find that you can do much better, if you have such a device, to produce the necessary pressure by turns, than by resonant rise, because if you want to excite it by resonance you have to link only a few lines; start with a very low electromotive force and work it up. But, if you have such a device as I have described, you can obtain any pressure you like by a few secondary turns. I have invented such an instrument and have demonstrated its efficacy.

Quod erat demonstrandum.

But, I usually do tune the fourth circuit. I am simply trying to point out an error existing in the present literature of radio telegraphy and telephony.

Counsel

One moment before you leave that -- you have spoken of the generator as illustrated here of low frequency; what did you mean by that?

Tesla

In my patents, frequencies were specified ranging all the way from about 1,000 per second up to 200,000 or 250,000, as I have set forth in the patents; but I have also indicated that the frequency will depend on what use the apparatus is to be put to. In the apparatus patent, I have stated that there were instrumentalities with which you can generate, if you like, electromagnetic waves. It will give you a very high pressure and a very big current. It is an ideal apparatus for the production of these electromagnetic waves. If you want to transmit electromagnetic waves, use a frequency of 500,000 if you choose; but, if you want to transmit the way I transmit, you will use a very low frequency so that the loss in these electromagnetic waves, which are thought to affect the receiver at a distance, but which have absolutely nothing to do with that receiver, and are only a delusion, should be minimized.

Counsel

Is this system a simplification of the same general principle of transmission as was illustrated by the coil in Colorado which you showed just a few minutes ago?

Tesla

Yes, this is the same apparatus. But, remember that in my patents I described a method, and I also described an apparatus for the carrying out of the method, which apparatus can be used for practicing any method of transmission. You see, those two things are distinct.

Counsel

Here [Fig. 65] you have shown an alternator connected into the primary of the circuit, and you say that this is the same apparatus you used in Colorado. I presume you are going to give a more full description of the Colorado apparatus?

System of concatenated tuned circuits shown and described in Tesla U.S. Patent No. 568,178 of Sept. 22, 1896, and corresponding arrangements in wireless transmission

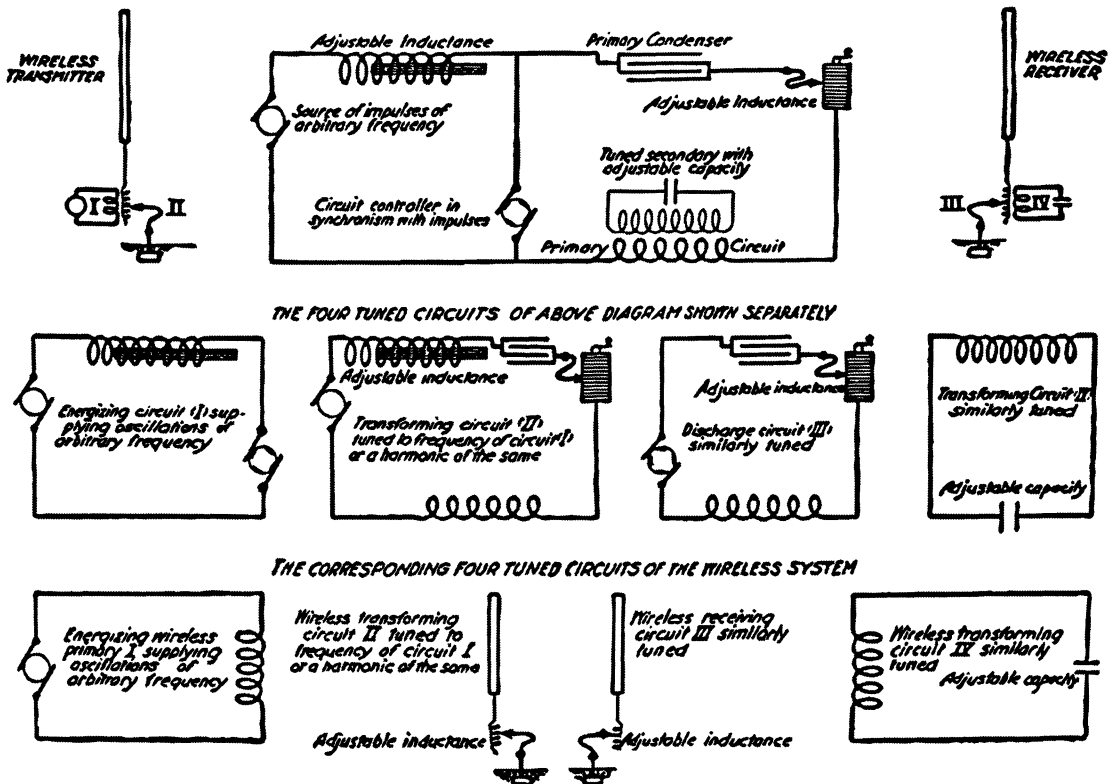

Figure 66.

Diagrams illustrating the system of four-tuned circuits as applied to wireless transmission. Described in U.S. Patent No. 568,178 of September 22, 1896. Application filed June 20, 1896.

Tesla

I will dwell on that later.

Here [Fig. 66] is something important, which I have tried to illustrate in a diagram. This diagram represents the system which I described in my patents of 1896, in which I showed four circuits in attunement, and I will endeavor to illustrate how these circuits are the exact equivalent of the wireless circuits.

You see, here on the top I have titled, "System of concatenated tuned circuits shown and described in U.S. Patent No. 568,178 of September 22, 1896, and corresponding arrangements in wireless transmission." The first circuit which I have here is composed of a controller, a source of impulses of arbitrary frequency, and an adjustable inductance. I have drawn that circuit separately, and you see it here; that is my first circuit, "Energizing circuit (I)," supplying oscillations of arbitrary frequency.

The second one is the circuit including the source, the adjustable inductance, this coil, and this primary. I have shown this circuit separately and marked it "Transforming circuit (II)" tuned to the frequency of circuit I, or a harmonic of the same.

The third circuit is formed by the primary, the self-inductance, and the controller, and it is shown as "Discharge circuit (III)" similarly tuned.

And then here is the fourth and last circuit with an adjustable capacity, shown as "Transforming circuit (IV)" similarly tuned.

Now, if you look at wireless diagrams and bear in mind that I have, first of all, established the equivalency between two-wire and one-wire transmission, that I have then gone a step further and established the equivalency between the transmission through one wire and the transmission through the earth, which is wireless, then you will readily see that these wireless arrangements which are popular now, are merely an imitation of my arrangements, are in fact, exactly the same. Here [top left] is a wireless transmitter, comprising a primary circuit I, in which current impulses of arbitrary frequency are produced, corresponding to the circuit (I) in this figure.

Here is the secondary tuned circuit connected to an antenna and to the ground, including an adjustable inductance, exactly as here; that is circuit II, which corresponds to this circuit (II) in my arrangement.

Then there is on the receiving side again the antenna circuit with an adjustable inductance, corresponding to my circuit (III) with the adjustable inductance and this capacity.

And then there is finally the fourth tuned circuit like my circuit (IV) with adjustable condenser. All is therefore a perfect, exact equivalent of the arrangements I described long ago.

This four-circuit arrangement has been claimed by others, but they overlook that I have patented that on September 22, 1896; and more than that, they overlook the fact that my Belgian patent, showing the exact arrangement of my American patent, was issued in 1898, prior to any suggestion by Ferdinand Braun, or Marconi, or other men who have come subsequently. Therefore, if these are the facts, my statement of them cannot be interpreted as slighting my fellow workers; I point it out merely as impersonal facts, and if these men have claimed that they originated this system it was merely due to ignorance on their part.

Now, it is important to give you a clear idea of the differences between the apparatus I produced and the contemporary apparatus. I have selected just these diagrams [Fig. 67] to give you, in a few words, the exact differences between the system I have developed and the system illustrated below in this diagram, which is typical of the systems that had been used prior to my invention.

This upper diagram is taken from my patents, and this lower drawing from a patent of Marconi which appeared in 1901. Certainly, it is proper to compare his arrangements with mine because they were used at the time when I brought out these principles.

As you see, here in this figure on the right, is my conductor connected to the ground and to the antenna, with absolutely no break in it. This other [in Marconi patent drawing] is a conductor connected to the antenna and the ground with a break in it. It cannot compare with mine because that break means resistance and diminution of the resonant rise. Furthermore, note the difference that I have here -- the primary energy passing into a transformer, and that these two circuits are tuned. There is no primary or a transformer in this Marconi arrangement. It is a wasteful system to begin with.

At the receiving end, as you see, I have again an antenna and a self-inductance in series with the ground and no break. He has a wire connected to the ground and to an antenna, a break or device of high, very high resistance with which it is absolutely impossible to obtain any practical results.

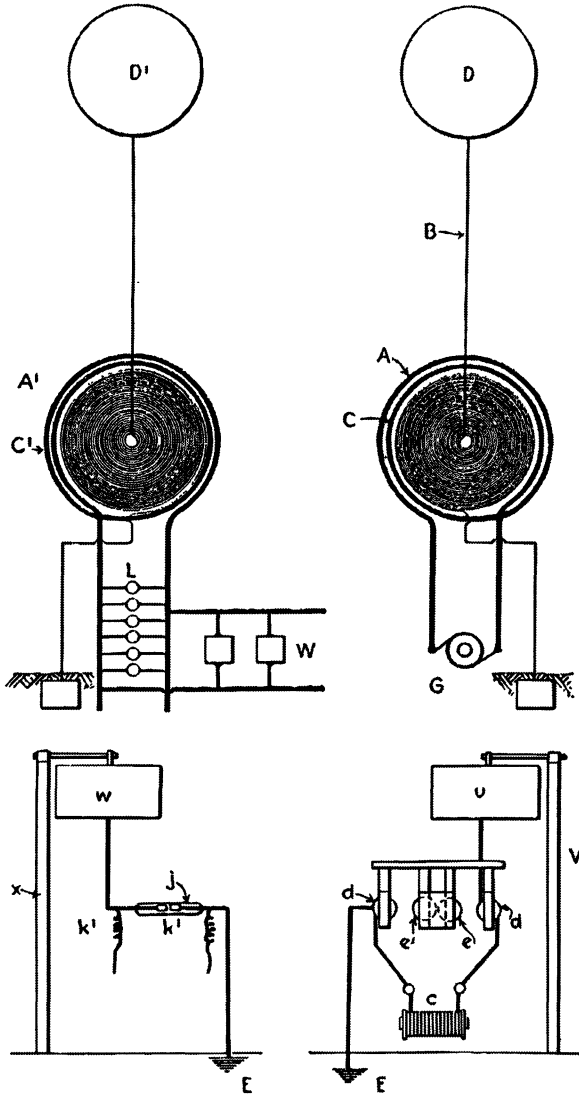

Figure 67.
 Diagram showing the salient differences between the apparatus described in these patents and the typical Hertz wave arrangements of that period described in the Re-issue Patent of Guglielmo Marconi, No. 11,913 of June 4, 1901.

My system is a system which can be perfectly attuned, and it will transmit to this antenna, here [at left], hundreds of thousands of times, millions of times, the energy which his device can transmit to his receiver.

Furthermore, my system is a system which is exclusive, which can be tuned and rendered private; that of Marconi cannot be tuned. Moreover, his transmitter generates electromagnetic waves of very high frequency, which are absorbed in the

air and penetrate only a few miles, while mine produces current waves which pass to the opposite point of the globe with the greatest facility, and can affect instruments at any distance.

If you take these two contemporaneous diagrams, and examine the subsequent developments, you will find that absolutely not a vestige, not a vestige of that apparatus of Marconi remains, and that in all the present systems there is nothing but my four-tuned circuits. Everybody is using them.

In changing this to my system, there is where the great step in wireless has been made. But, as a matter of fact, this came gradually. When my experiments with the magnifying transmitter were published in the Electrical Review [New York, Mar. 29, 1899], there is where the radio men recognized the necessity or the advantage of going to lower frequency. They started out with very high frequencies, and you will hear it asserted that prior, say, to 1901, there were frequencies of 2 million used. There is no truth in that. Long before 1901 the radio men had followed my lead, and they had gradually reduced their frequencies; and when in 1900 I published these results in the Century Magazine and showed that these were obtained with a frequency of 50,000, there was a stampede for these frequencies. [T]hese frequencies have been adopted by all experts before 1901, so that there is no truth in the statement that very high frequencies had been used subsequent to that date. It was only in the very beginning that very high frequencies were employed, but they were gradually abandoned, until in 1900 everybody began to use low frequencies.

Counsel

Was this system of yours used in anything but experimental work?

Tesla

Why, there is no other system that is [emphasis in original] used. Every wireless message that has ever been transmitted to any distance has been transmitted by this apparatus; there is no other way. Mr. Marconi came here, when he announced that he had made a transmission across the Atlantic. I congratulated him. I said to my secretary,

"I cannot understand how Marconi could obtain these results. His apparatus cannot do this; he must use my apparatus."

My secretary said,

"How can Marconi use your apparatus when here is his statement that he had tried it and it did not work?"

But, when you examine the publications of a year later, you will note Marconi comes out with the statement that he had used these four circuits, and the only excuse that he has put up is that he did not know that these four circuits had to be attuned. That was his excuse. And in the meantime, he had been using this apparatus. Every message that has ever been transmitted to any distance, by telegraph or telephone -- wireless, has been by the use of these instrumentalities and no others.

Counsel

Your experimental [work], as I understand, was on a considerable scale. Describe the size and use of those experiments.

Tesla

They were only experimental in the sense that they were preparatory steps to the construction of a big plant which I undertook to erect. You see, my apparatus of 1896, exhibited in my laboratory, was sufficient to flash a message across the Atlantic; but I was preparing for a very big undertaking, and as the things then looked I was capable of putting that undertaking financially through; I had excited the interest of a great man. But, when the radio business assumed the phase of stock jobbing, that great man said to me,

"I could not touch it with a 20-foot pole,"

and there I remained stuck with my project and unable to carry it through. But, I undertook the design and construction of a plant for telephony around the world, and just as certainly as you can hear my voice across this small space, you would hear my voice across the whole globe if I had completed that plant.

Counsel

You have spoken of these stations, elsewhere, as not commercial. I spoke of your experimental stations. In what way do you use the word "commercial"?

Tesla

Why, I mean commercial in the sense that you are transmitting messages for a charge.

Counsel

These stations that you constructed -- and let us refer to your Colorado station -- was the construction and operation on a scale adapted to commercial work?

Tesla

Yes, it was not only adapted, but better adapted than any plant that has since been built. I had in my Colorado plant a current of 1,000 amperes in the antenna. The biggest radio plants today develop something like 200 or 250 amperes in the antenna. Remember, also, that my current was under a great tension. My current was under a tension of 3 1/2 or 4 million volts, others only 30,000 volts; so you can imagine the enormous difference between the energy of the vibrations which I produced and those in the present plants.

I had a capacity of 500 or 600 centimeters [i.e. 550 or 660 picofarads], but this capacity was charged to 4 million volts; they have a capacity of, maybe, 18,000 or 20,000 centimeters [i.e., 0.020 or 0.022 microfarad], whatever it is, but they charge it only to 30,000 volts. You know the energy of a system depends on the square of the potential. If I used a capacity, say, one-tenth of that and I charged that capacity to a thousand times greater potential, I have an immeasurably greater energy in my system. [T]his is only possible, as I said, through the observance of the rules which I have already explained, which enable me to economize in the production of electromagnetic waves, to suppress them as much as possible, and to intensify the current which can perform work at any point of the globe.

Counsel

Going back for a moment, what was the longest distance over which there was actual radio transmission?

Tesla

I have already stated that the greatest distance that I ever transmitted was from Houston Street to West Point.

Counsel

Does that include Colorado also?

Tesla

Oh, at Colorado there was a difference. In Colorado I demonstrated --

Counsel

I do not want to get these things mixed up; are they the same thing?

Tesla

No, not the same thing. This system of [Fig. 67, upper diagram] is the system I have described.

Counsel

Was that used out in Colorado?

Tesla

Oh, the Colorado apparatus was on the same principle, but looked different.

Counsel

Referring to this [Fig. 67, upper diagram], was this used only here in New York?

Tesla

Only here in New York.

Counsel

That is what I want to get clear in my mind.

Tesla

Only here in New York, and with this apparatus exactly as described in my patent I transmitted from my laboratory on Houston Street to West Point, and that was the biggest distance that I ever transmitted.

Counsel

In the Colorado apparatus, did you have a spark gap in the transmitting set?

Tesla

Oh, I sometimes had a spark gap, but not in the antenna. The antenna circuit was always grounded without any break.

Counsel

But your oscillator there was a spark oscillator?

Tesla

Oh, sometimes, yes. But, pardon me; in my patents I described both a dynamo and my transformer, and those two things are equivalent.

Counsel

I understand that, but I am speaking about what you actually used in Colorado.

Tesla

In Colorado I used the spark gap method because I could not get from any high frequency machine any such amount of energy. That is the point. But I used damped and undamped waves -- both.

Counsel

I have read in some of your writings that you went to Colorado to further experiment with certain apparatus which you had tested to your own satisfaction at sea level. What was the reason that you went to Colorado to continue those same experiments?

Tesla

I built the Colorado experimental station preliminarily to the installment of a large plant on Long Island, which I was designing at that time. I had some friends who were willing to back me up financially, but I did not care to take the responsibility. I told them that I could do it without any further experiment but, in order to satisfy myself of everything, I preferred to go to Colorado, spend \$50,000 out of my own pocket, demonstrate the proposition, and then go to the financiers who were willing to trust me and say,

"I am now prepared to build."

Counsel

I was not asking for the personal reason as much as the scientific reasons. What I wanted to get at, was that demonstration undertaken in Colorado for the purpose of getting the higher altitude of the air?

Tesla

No, it was nothing of the kind. I simply went there because in Colorado my system of power transmission was introduced. All around the plants in the mountains, my three-phase system, and the induction motors were employed. All the mines surrounding Cripple Creek and Telluride were operated by them, and I had friends there who were only too delighted to give me all the power I wanted, and not charge anything for it. And furthermore, the climate was praised up very high. Of course, when I came to Colorado Springs I discovered that 30,000 consumptive were there, out of 35,000 inhabitants. And then I

made a remark, for which I was nearly chased out; I said that Colorado Springs was a nice place but only two kinds of people ought to go there -- those who have the consumption and those who want to get it. I was nearly chased out.

My experiments [on Houston Street] showed that at a height of 5 miles the air was in conduction to transmit the energy in this way, but my experiments in Colorado showed that at a height of 1 mile it is plenty enough rarefied to break down under the stress and conduct the current to the distant points.

I have to say here that when I filed the applications of September 2, 1897, for the transmission of energy in which this method was disclosed, it was already clear to me that I did not need to have terminals at such high elevation, but I never have, above my signature, announced anything that I did not prove first. That is the reason why no statement of mine was ever contradicted, and I do not think it will be, because whenever I publish something I go through it first by experiment, then from experiment I calculate, and when I have the theory and practice meet I announce the results.

At that time I was absolutely sure that I could put up a commercial plant, if I could do nothing else but what I had done in my laboratory on Houston Street; but I had already calculated and found that I did not need great heights to apply this method. My patent says that I break down the atmosphere "at or near" the terminal. If my conducting atmosphere is 2 or 3 miles above the plant, I consider this very near the terminal as compared to the distance of my receiving terminal, which may be across the Pacific. That is simply an expression. I saw that I would be able to transmit power provided I could construct a certain apparatus -- and I have, as I will show you later. I have constructed and patented a form of apparatus which, with a moderate elevation of a few hundred feet, can break the air stratum down. You will then see something like an aurora borealis across the sky, and the energy will go to the distant place.

That is very simple. An apparatus which permits displacing a certain quantity of electricity in the terminal -- we shall say so many units -- will produce an electric potential at a distance of 5 miles, and the fall of electric potential per centimeter will be equal to the quantity of electricity divided by the square of the distance.

Now, I have satisfied myself that I can construct plants in which I may produce, per kilometer of the atmosphere, electric differences of potential of something like 50,000 or 60,000 volts, and at 50,000 or 60,000 volts that atmosphere must break down and will become conductive.

So that, when I had explained this principle to Lord Kelvin, he became absolutely convinced that I could do it; but Helmholtz was convinced from the very beginning that I could do it. It took argumentation, however, and demonstration by experiments, to convince Lord Kelvin.

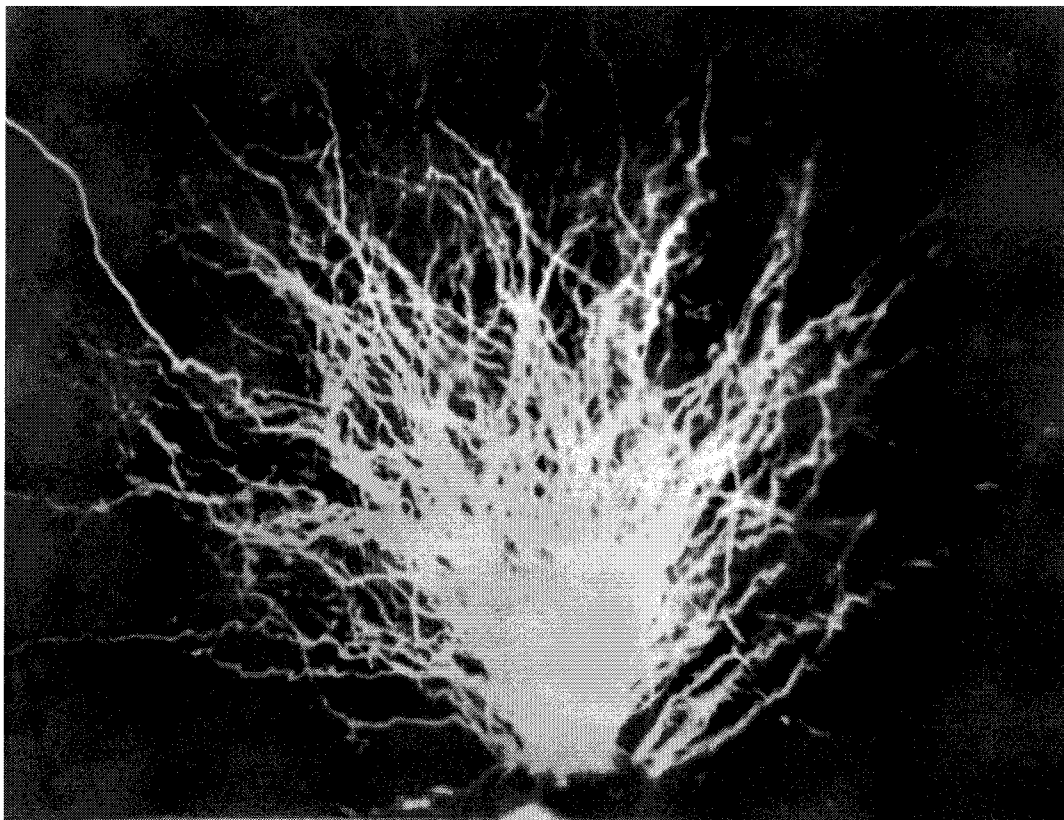

Figure 68.

Powerful discharge from a transmitter constructed in accordance with principles set forth in U.S. Patent No. 1,119,732 of December 1, 1914.

Here [Fig. 68] I have a photograph to just give you a striking illustration of some of these effects. This thing that you see here is a large ball [pointing to the bottom of the photograph], on top of a cylindrical conductor, lifted above the roof. The roof was removable made in two parts, which could be slid apart. The ball could be pushed up and down and lifted to a certain height as I needed it. The experiment shows just that kind of arrangement which I have illustrated in previous diagrams and with which I reached enormous potentials. So great was the pressure that the ball discharged into the air and I have been able to follow for a 100 feet some of these streams. That will give you an idea what a tremendous display it must have been. The current passing through this ball was about 1,000 amperes and the display, seen from a distance, was such that people might have thought the building afire, and many times they did think so.

Counsel

What was the voltage of it?

Tesla

In this experiment, the voltage might have been something like 7 or 8 million volts, but I want to tell you, though, that I am referring to the maximum potential. The moment you get these enormous streamers the potential drops. I mean that was the breaking potential.

Counsel

You had to store the energy in the condenser for a certain length of time and then let it out all at once?

Tesla

Yes, that is a natural process -- in a small interval of time.

Counsel

You could not have kept this display up merely from the energy of the alternator itself?

Tesla

No, sir, I could not have kept that energy up, but I will tell you the secret of all these wonderful displays. It is now perfectly well understood, but at the time when I did this work it was not understood. Consider a gun, for instance, a large gun which hurls a projectile of a ton a distance of 18 or 20 miles. There is a German gun now that fires at 28 miles. If you figure the horsepower at which guns deliver energy, you will find that it amounts to from 6 to 12 or 15 million horsepower. That is, the biggest gun may develop energy at the rate of something like 15 million horsepower, if my recollection of calculations I made is correct. With the methods I devised, with my transformer, it is not at all difficult to get rates of energy many times that, and I have, for instance, figured that in the plant on Long Island, which I put up, under certain conditions, if I wanted to operate, I could have just reached a rate of 1 billion horsepower.

That wonderful thing can be accomplished through a condenser. The condenser is the most wonderful electrical instrument, as I have stated before. You store less energy in the condenser than in the gun but, whereas a gun will discharge the projectile with a velocity of 2,000 feet per second, which means that the energy is delivered in, say, 1/50 of a second, a condenser can discharge the energy in 1 millionth

of this time. Thus, if you store in the condenser energy at the rate of 100 kilowatts, and then discharge it in oscillations of 250,000 per second, it means that you have to multiply these 100 kilowatts with 1 million; therefore, you have a 100 million kilowatt rate as the current discharges. So, all these effects which were produced, and which elicited, of course, great wonderment of the profession, were always produced by damped waves, because with the undamped waves it would not have been possible to attain any such activities.

In the plant in Colorado, my problem was to learn how to construct the apparatus and how to handle these enormous forces which it was necessary to control in a big industrial plant. In these effects, I took a scientific interest and these photographs were intended to show to the world that it was not a dream, what I was doing. That was the sole purpose, but I would not do that in a commercial plant. It was simply to show the marvelous power that could be developed with the apparatus I had perfected.

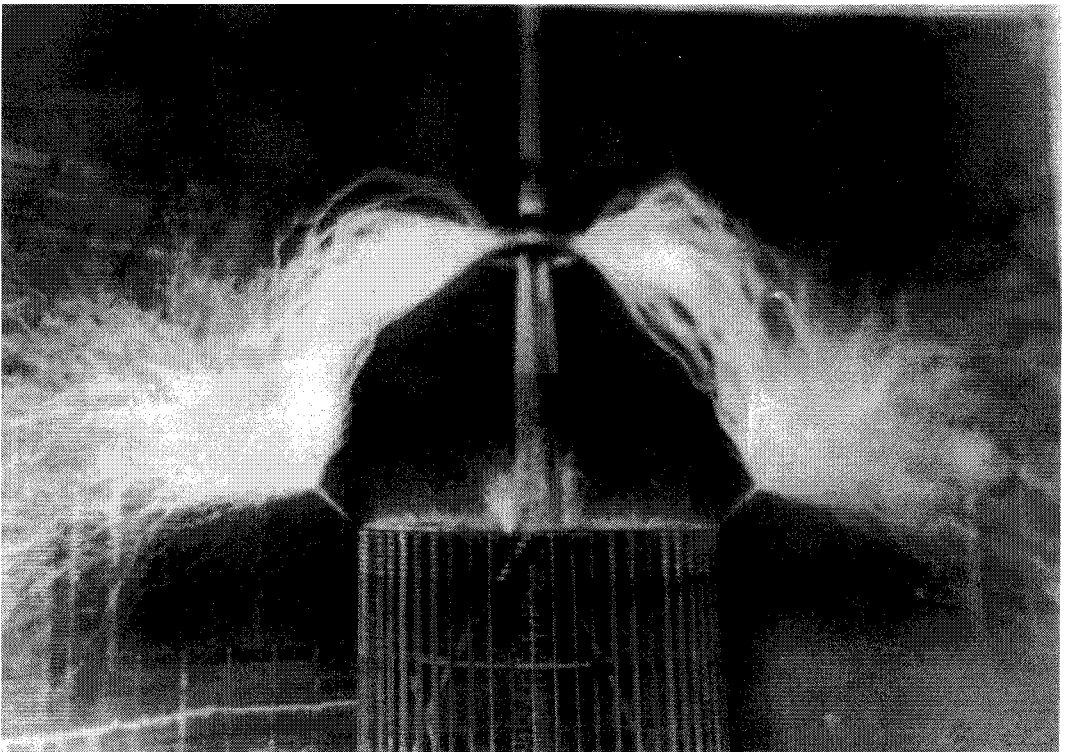

Figure 69.

Experiment bearing out the importance of the principles of design embodied in the transmitter described in U.S. Patent No. 1,119,732 of December 1, 1914.

I thought that with a few photographs of this kind [Fig. 69] I would throw light on the apparatus. Here, you see [top center], is a cylindrical antenna. This antenna was put up in 1899 and was a landmark for several years. Everybody has seen it. Therefore, when I am told that other people have used cylindrical antennae before, that cannot be true because I have done that in 1899 -- always in public and everybody has seen it.

As you see, this bit of curve behind, that is my self-induction in series with the antenna, which generates this alternating force, and there is another self-induction coil, and the whole circuit tuned to resonance. The antenna is not connected now. That is a perfectly insulated capacity, but the current passes into it, leaping through a great distance, something like 12 or 15 feet, with a tremendous display on both sides.

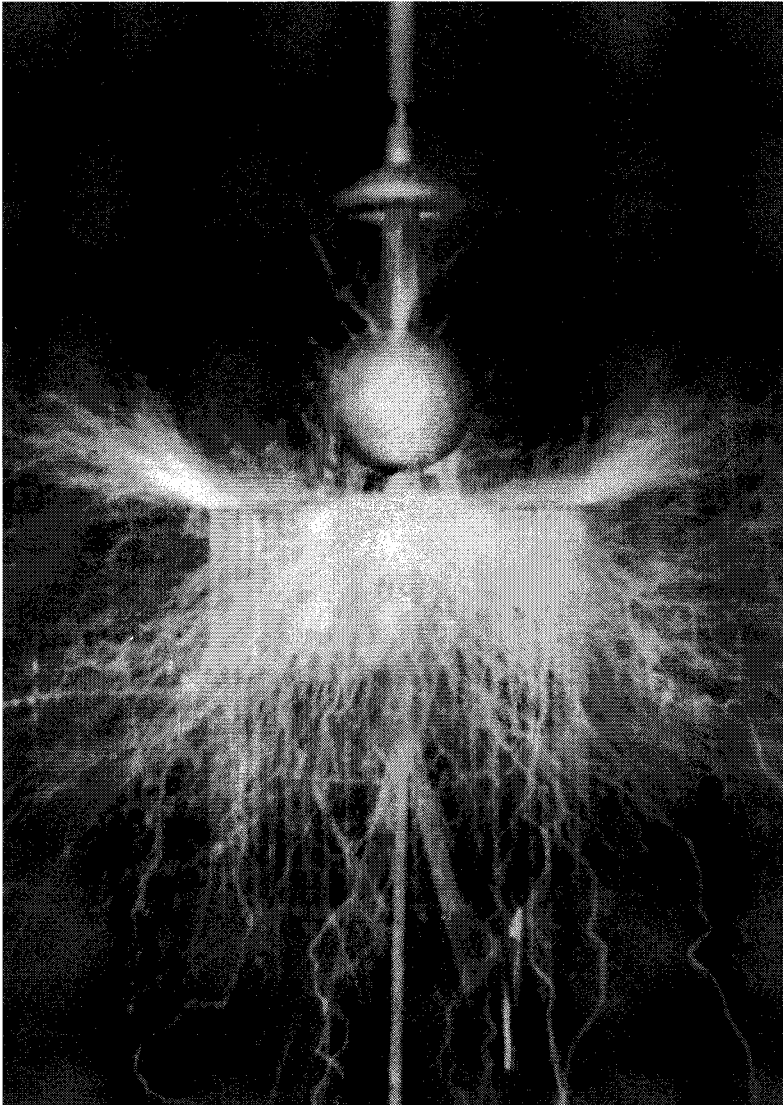

Figure 70.
Another experiment conveying an idea of the great quantity of electricity set in movement, as borne out by mechanical analogue.

This [Fig. 70] was illustrated and explained in my article in the Century Magazine of June 1900, page 191. This is an experiment which is wonderful, and I want you to understand its meaning. Here I have a ball, a very large ball, connected to the circuit.

Counsel

That is made of what?

Tesla

This ball is of wood, covered with metal, because the electricity does not go into it, and it does not get hot, so it is perfectly safe to employ wood. Around here is a bent 2-inch pipe -- a bare pipe. I put it there because if I did not do so my insulation would immediately catch fire; therefore, I had to protect it. In this experiment there is a distance of about 60 feet from here to there [*], and through this pipe electricity escapes into the air.

To explain this phenomenon, imagine, presently, that you had a big water main, say a main that supplies the city, and on that main a gate valve, and before that valve a reservoir which could stand a great pressure. Suppose that you turn the pressure on this main and that the water cannot flow out; then there will be full pressure on that reservoir, but if you open the valve wide, the moment it is opened the pressure will go down to nothing if the main is large. Therefore, in the reservoir before the valve, there will be no pressure. Here is the electrical main. This pipe [Fig. 70], out of which the electricity escapes in a powerful stream, is the open water main -- a large main through which the water can freely flow out. This ball here is the reservoir on the end of the pipe, a reservoir which can stand a tremendous pressure, and notwithstanding that this main is open, and that all the electricity, probably 800 amperes, can flow out readily, nevertheless the pressure on the open main is so great that this reservoir bursts under the stress and you see streams coming out of the ball. That is a wonderful thing. It shows the volume of the discharge.

Counsel

Has that any relation to the aurora borealis effect that you referred to awhile back [at p. 110]?

Tesla

No, sir; not at all. This is simply a scientific experiment.

* Editorial note: Points referred to not known.

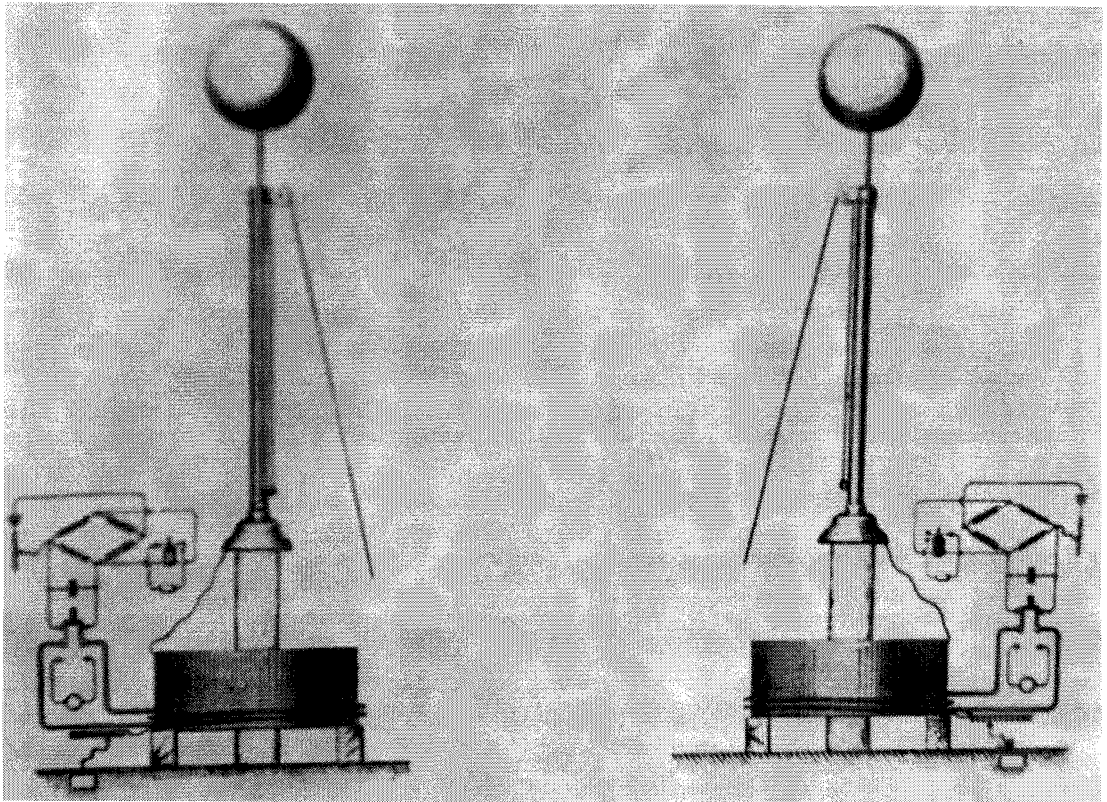
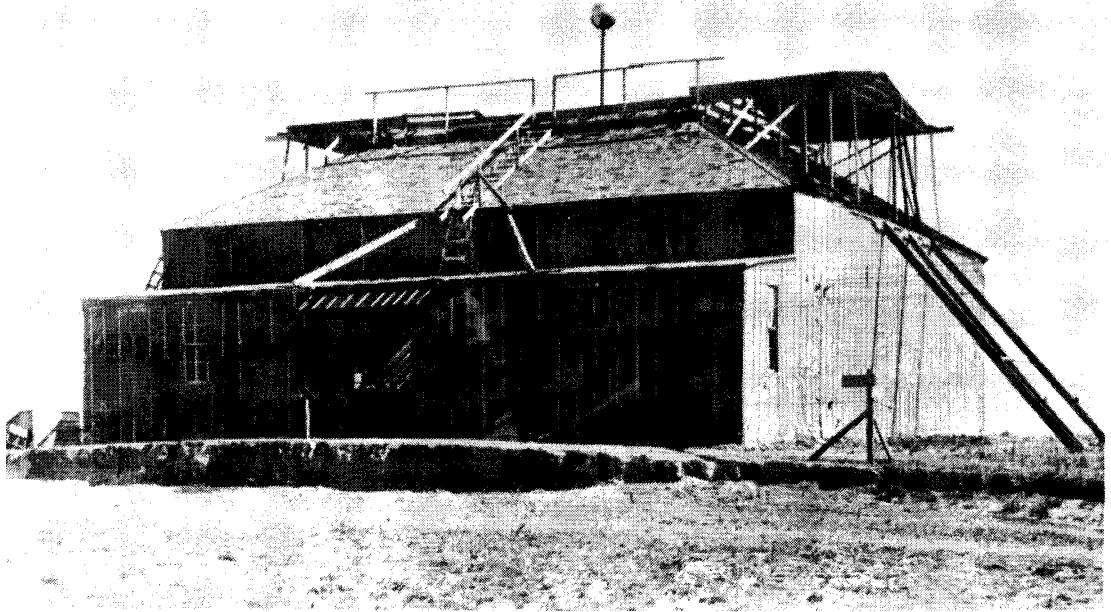

Figure 71 (verso, top).

Distant view of experimental wireless station at Colorado where these experiments were performed. The terminal protruding above the roof is adjustable.

Figure 72 (verso, bottom).

Diagram showing the general arrangement of transmitting and receiving circuits with adjustable capacities as used prior to 1900 and subsequently.

There [Fig. 71] is a view from a distance of my plant at Colorado Springs. You see here the removable roof, through which I could pull this capacity up and down. There is a pipe of 8 inches in diameter, and on top of it is a ball. That was my capacity. That is the capacity from which you have seen the streamers come out in one of the previous photographs [Fig. 68].

This [Fig. 72] is simply intended to show how I operated these adjustable capacities. Here is a pipe, and a ball on top of it, an arrangement of a transmitter and receiver. These capacities lifted up and adjusted. This is a drawing of 1897 or 1896, possibly.

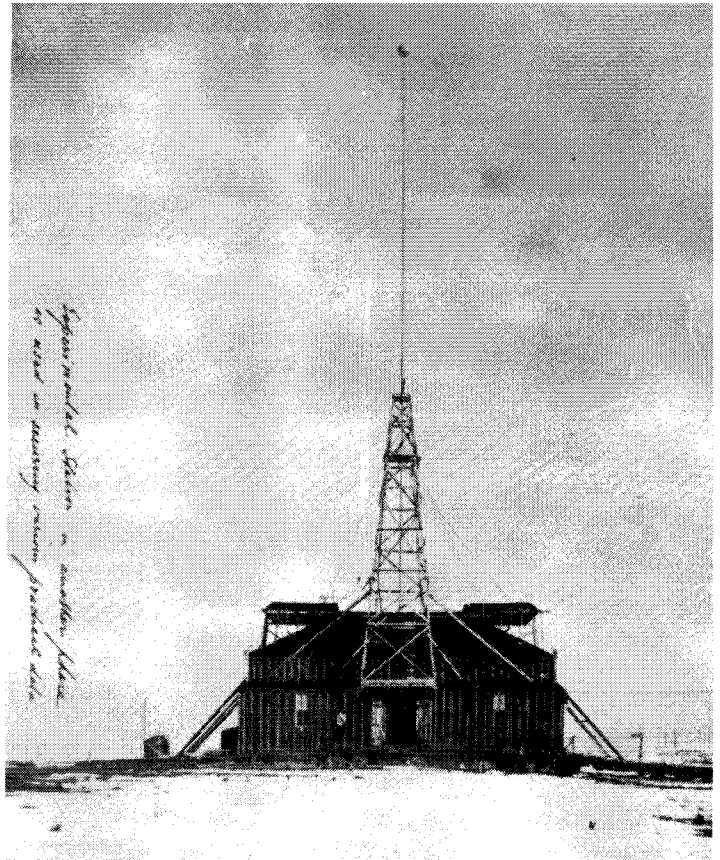

Figure 73.

A distant view of the experimental station at Colorado in a phase of development showing the cylindrical antenna, 168 feet in height.

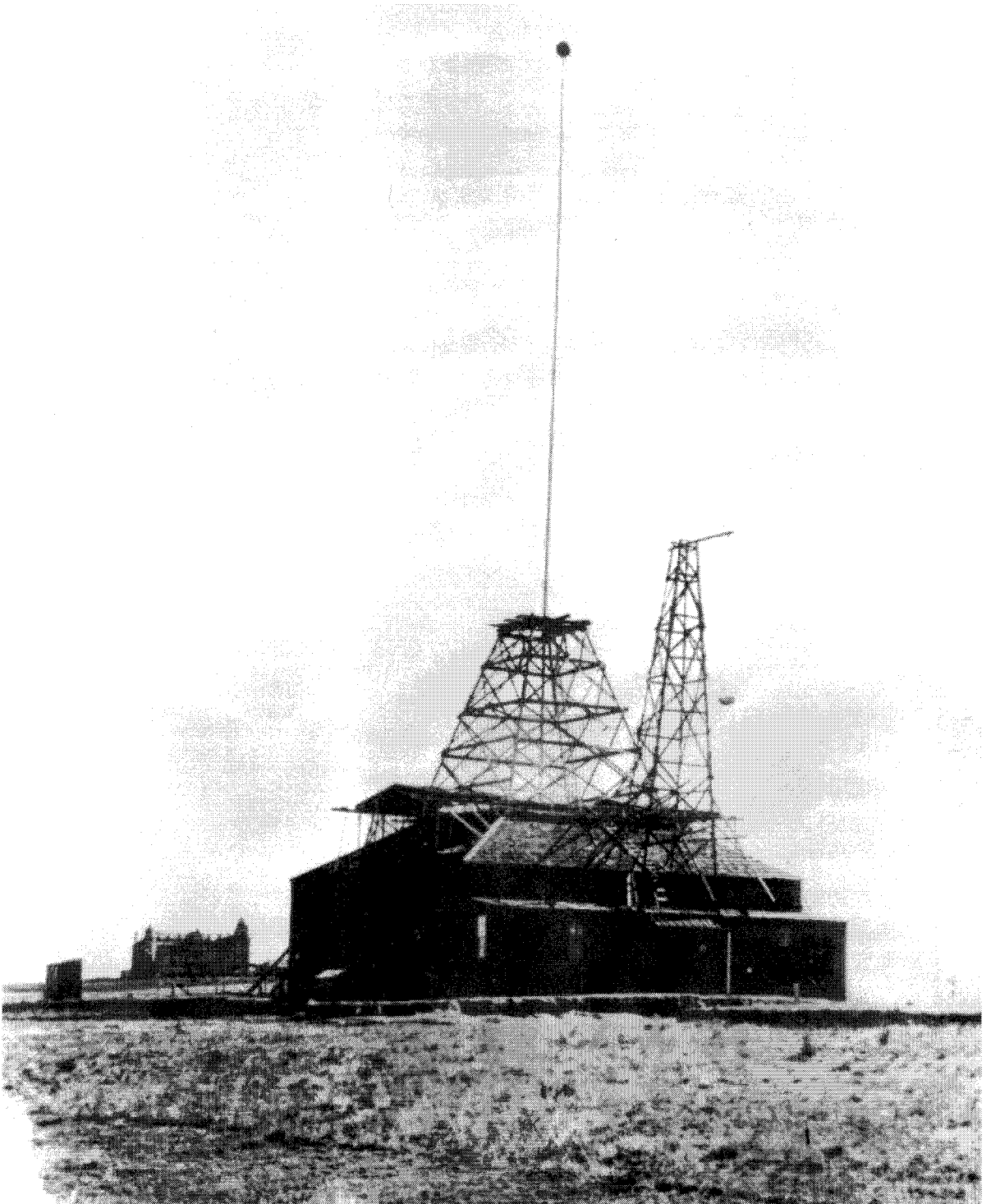

Figure 74.
Another distant view of the experimental station at Colorado showing the structure used to determine rate of incremental capacity with reference to earth.

Here [Fig. 73] is another view from a distance. This is the cylindrical antenna reaching a height of 168 feet.

I take the liberty of pointing to this little structure on the side [Fig. 74, shorter mast at right]. [Note] this ball suspended here. That is just an experiment which I was making in the measurement of capacity, determining the rate of increment of the capacity with reference to the earth.

Counsel

When was that put up in that form? Does that represent some change over the earlier photograph?

Tesla

No, it does not represent change. It represents simply various steps in my experiments. As I proceeded in my investigations, I was gradually increasing the antenna and studying the effects I was getting, but I always remained true to the principle to arrange my conductors on a radius of large curvature so as to enable me to work up very high potentials with low surface densities. Now, for instance, you will find illustrated in patents cylindrical structures of wires. I know of an illustration showing a cylindrical antenna made up of wires, but when I figure the density of distributed charge I find that it was an ozonator; it was not an antenna such as my own. It generated ozone. The densities on this thing were enormous, even with low potentials. I have kept my large curvatures, my large surface, so that nowhere would I get an excessive density. Nevertheless at night, this antenna, when I turned on the full current, was illuminated all over and it was a marvelous sight.

Counsel

When you used the higher potentials?

Tesla

Yes.

Counsel

This was a column you say 168 feet high?

Tesla

Yes.

Counsel

And the diameter of that column was what?

Tesla

I think the first pipe was 10 inches or 11 inches, and then it gradually diminished in a few sections.

Counsel

And the size of the ball on top?

Tesla

The ball on the top [was], I think, 32 inches [in diameter].

Counsel

What was the column itself made of?

Tesla

Ordinary iron pipes.

Counsel

Wrought iron pipes?

Tesla

Wrought iron pipes, yes.

Counsel

What was the ball made of?

Tesla

The ball was of wood covered with metal.

Counsel

And the column was insulated with what from the ground?

Tesla

That was supported on a special tree of fir. I went to the lumber men and tried various woods and could not find anything until I discovered a magnificent piece of a certain kind of fir. I took samples, tested them, and found that they were very highly insulating. I tested the fiber and found it was prodigiously strong and amply sufficient to support the antenna. As a matter of fact, it carried it for 4 years.

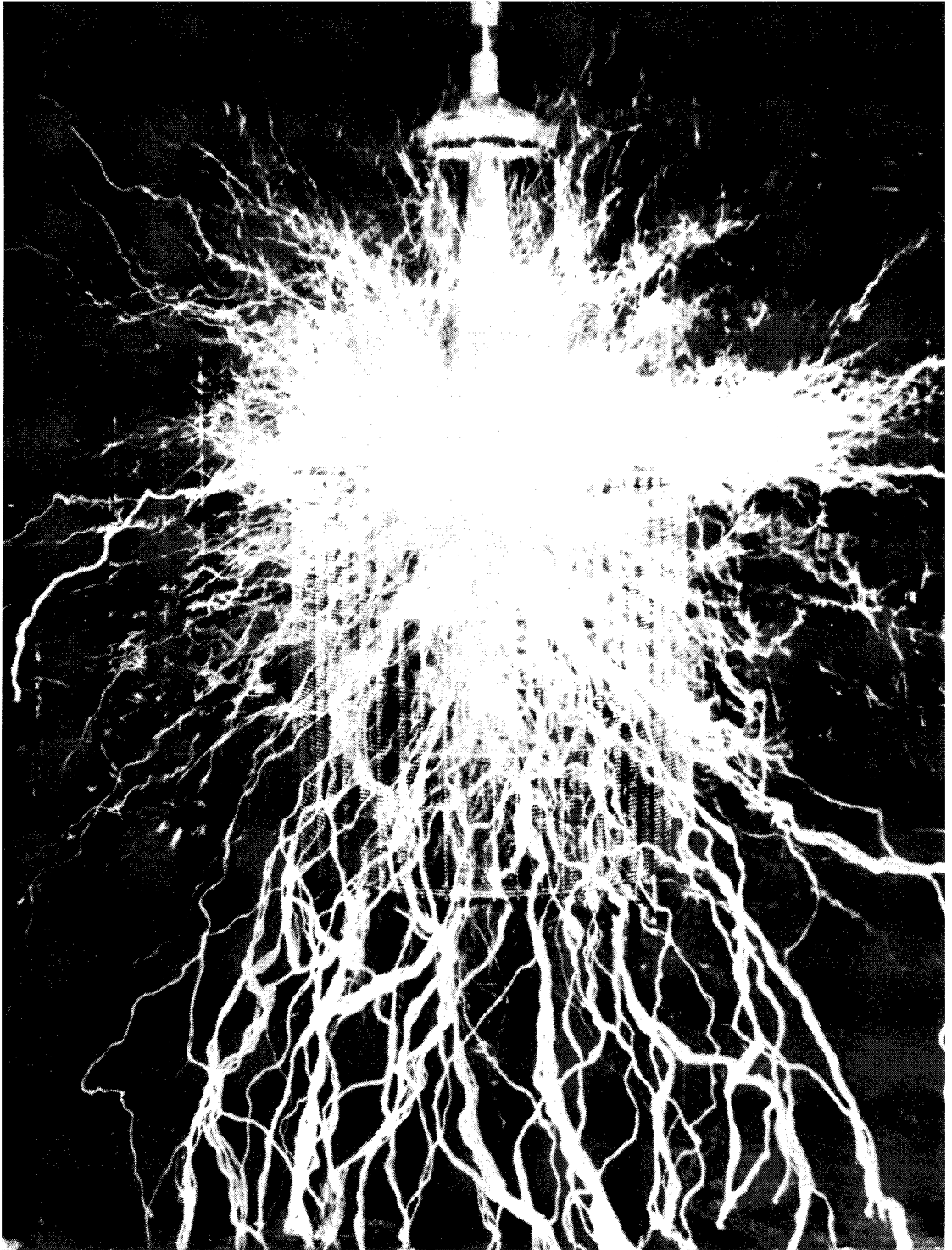

Figure 75.
Discharge of a powerful transmitter under a pressure of 12 million volts,
70 feet from end to end. (Article, "The Problem of Increasing Human
Energy," Century Magazine, June 1900, Fig. 10, p. 192.)

Counsel

When was it completed in this case?

Tesla

In November -- probably late November, 1899.

That photograph [Fig. 75] is illustrated in my article in the Century Magazine of June 1900, and it shows a remarkable display. When I sent these photographs to such men as Lord Kelvin, Sir William Crookes, Sir James Dewar, Roentgen, Lenard, Slaby, and others, some of them cabled me expressing their wonderment at how I produced these effects.

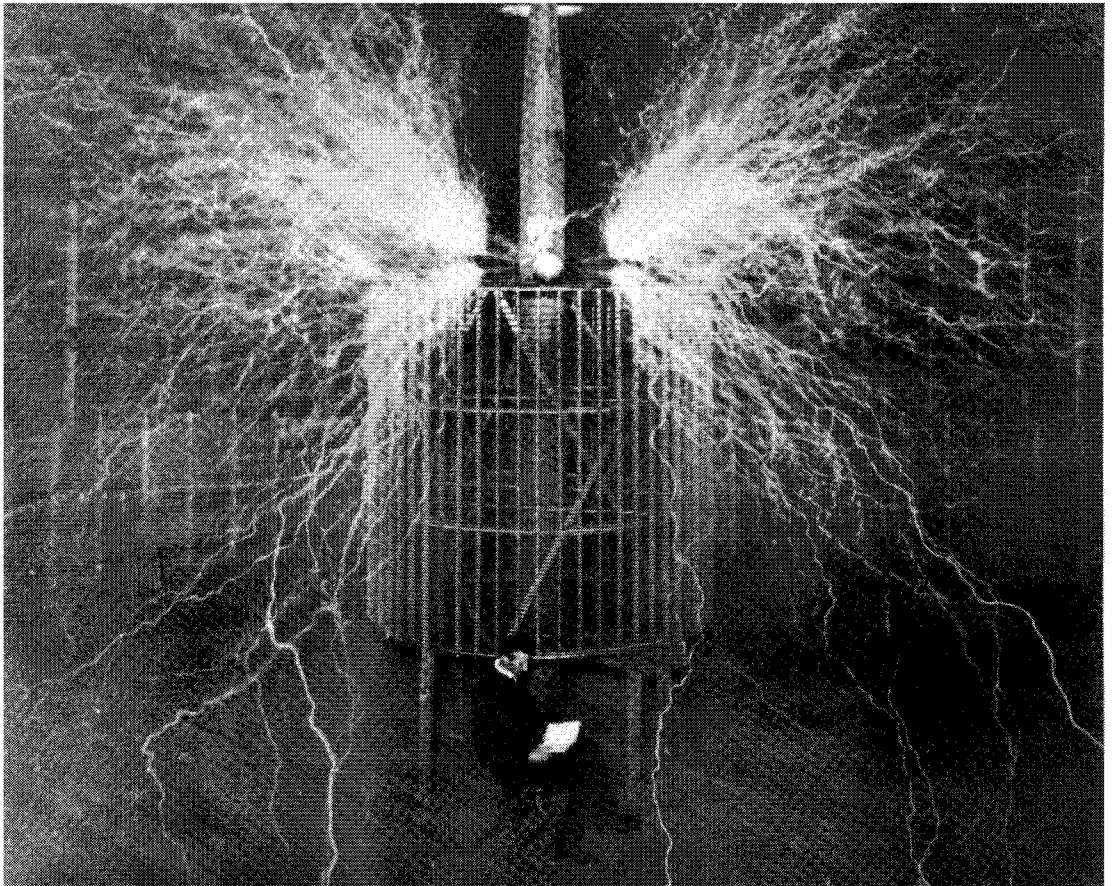

Figure 76.

Another discharge remarkable for symmetry at Colorado plant.

Here [Fig. 76] is another one. There is the fir tree which I obtained, and on top of it is the antenna peculiarly supported; namely, as it is explained in one of my patents. It is imperative to support a system of that kind on places of low electrical density. If I do not support it on places of low electrical density, then the first thing that will happen

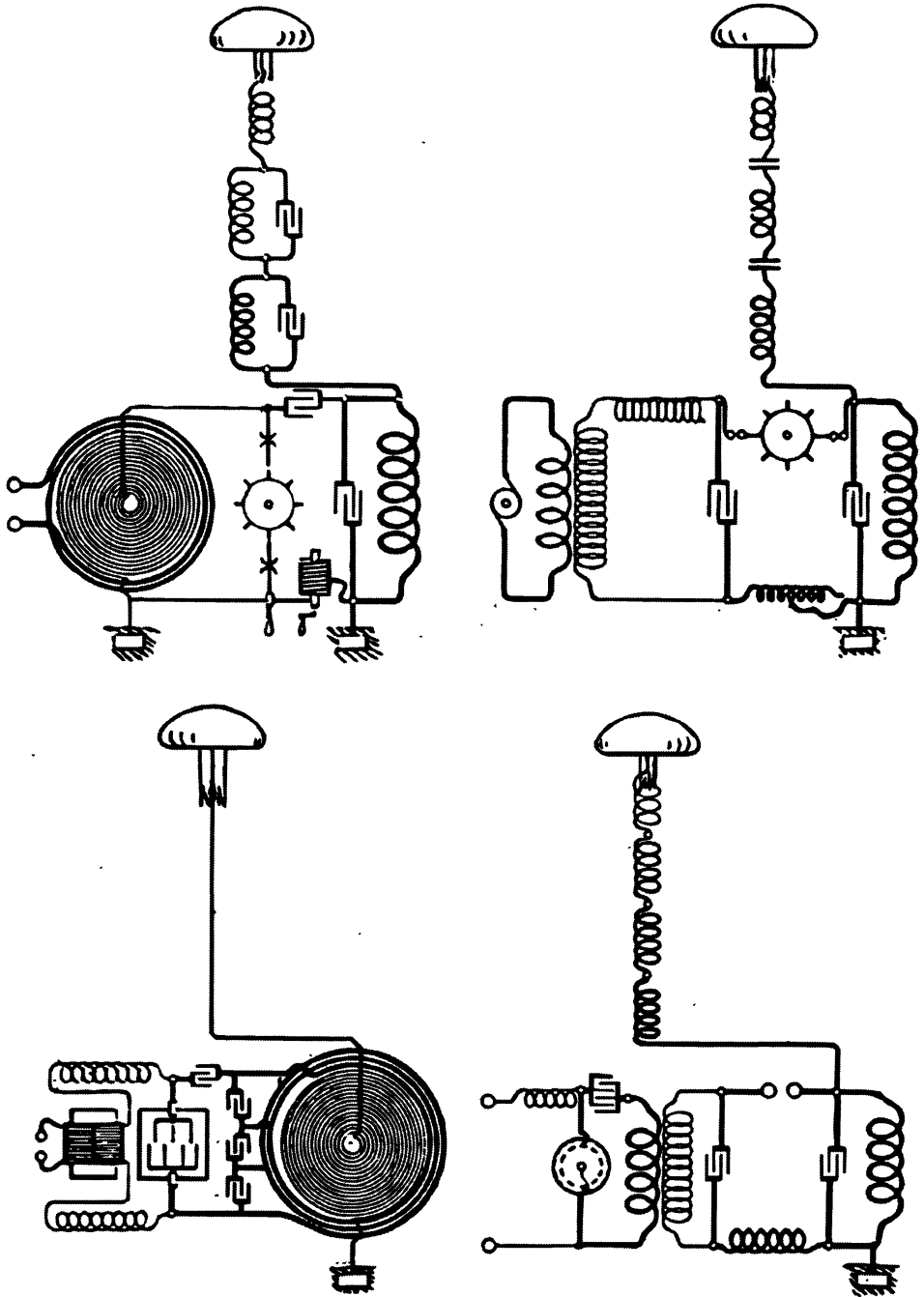

Figure 77.
Diagram illustrating use of sectional circuits. Suggested in St. Louis lecture. Employed in Houston Street laboratory and in Colorado.

will be surface conduction enabling the current to flow to earth, and before one knows the antenna will be grounded and everything destroyed. But, by providing a sort of roof, I get on the under side a support on which the electrical density is nothing, and then the support is absolutely safe, even in rain, because it keeps dry, and it is always in contact with a conducting surface of low electric density.

There [Fig. 77] is another improvement which I carried out in the laboraories on South Fifth Avenue and Houston Street, and which I also employed in Colorado. That is, the employment of sectional circuits. I had sometimes as many as 20 of these sections. There are specific results which can be obtained with these sectional circuits, but the technical literature is full of illustrations which are erroneous, showing apparatus that clearly could not work. That is a special subject on which I have spent a great deal of time, and in this short account of this work I can do no more than just say that these various sections are tuned either to the same or to different frequencies. I sometimes tuned them to compound frequencies and then worked with the fundamental tone, corresponding to the Fourier harmonic. Professor Stone has also done a great deal of work in that direction. I do not know who of us would be prior in records.

VII. Theory and Technique of Energy Transmission

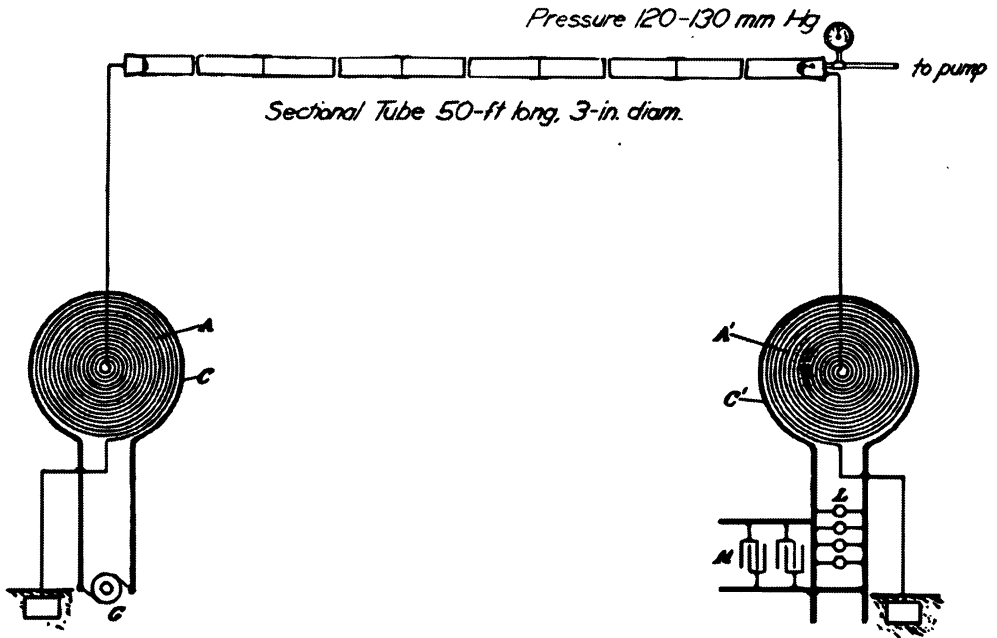

Figure 78.

Experimental demonstration in the Houston Street laboratory, before G.D. Seeley, Examiner in Chief, U.S. Patent Office, January 23, 1898, of the practicability of transmission of electrical energy in industrial amounts by the method and apparatus described in U.S. Patents No. 645,576 and No. 649,621. Applications filed September 2, 1897.

Tesla

This [Fig. 78] is a diagram representing the arrangement of apparatus as in a practical experiment which I performed before G.D. Seeley, Examiner in Chief, U.S. Patent Office, on the 23rd of January, 1898. This experiment illustrates a great departure I had made a little prior to that date. Up to the end of 1896, I had been developing the wireless system along the lines set forth in my lecture which is in the Martin book, particularly in the chapter on Electrical Resonance, pages 340-349. As I stated then, if that plan of mine was practicable, distance meant absolutely nothing; distance merely came into consideration when you flashed rays, electromagnetic or Hertzian waves, or some agency of that kind. By the plan I had conceived, if it was realizable, it was just as easy to telegraph or telephone across the entire globe as it is across this room.

Developing along these lines, my effort was first to have the biggest possible capacity because I had shown that, theoretically, the effect would be dependent upon the quantity of electricity displaced. The quantity of electricity displaced is proportionate to the capacity. Therefore, in order to realize my scheme, it seemed necessary to employ the biggest possible capacities that could be practically constructed; that was my idea at the beginning.

But I knew also that even with a big capacity, if I connected it to the ground, through a generator, there still would be a frequency high enough to cause a considerable loss of energy in the production of the Hertz or electromagnetic waves; consequently, I had to employ also a very large inductance. Thus, my system was based on the proposition that I employ a very large inductance and a very large capacity and, furthermore, that I raise the potential of the source so high, by resonance, as to displace a quantity of electricity big enough to affect sensibly not only the near portions of the globe, a distance of 100 miles or so, but the whole globe.

In [my] Houston Street laboratory, I had already satisfied myself that it could be done. But in experimenting with these high potential discharges which I was always producing, I discovered a wonderful thing. I found, namely, that the air, which had been behaving before like an insulator, suddenly became like a conductor; that is, when subjected to these great electrical stresses, it broke down and I obtained discharges which were not accountable for by the theory that the air was an insulator. When I calculated the effects, I concluded that this must be due to the potential gradient at a distance from the electrified body, and subsequently I came to the conviction that it would be ultimately possible, without any elevated antenna -- with very small elevation -- to break down the upper stratum of the air and transmit the current by conduction.

Having discovered that, I established conditions under which I might operate in putting up a practical commercial plant. When the matter came up in the patents before the Examiner, I arranged this experiment [shown in Fig. 78] for him in my Houston Street laboratory.

I took a tube 50 feet long, in which I established conditions such as would exist in the atmosphere at a height of about 4 1/2 miles, a height which could be reached in a commercial enterprise, because we have mountains that are 5 miles high; and, furthermore, in the mountainous regions we have often great water power, so that the project of transmitting it, if the plan was rational, would be practicable.

Then, on the basis of the results I had already obtained, I established those conditions, practically, in my laboratory.

I used that coil which is shown in my patent application of September 2, 1897 (Patent No. 645,576 of March 20, 1900), the primary as described, the receiving circuit, and lamps in the secondary transforming circuit, exactly as illustrated there. And when I turned on the current, I showed that through a stratum of air at a pressure of 135 millimeters, when my four circuits were tuned, several incandescent lamps were lighted.

Counsel

What did you use as the source of energy in your primary transmitting circuit, at the time you demonstrated this apparatus to Examiner Seeley?

Tesla

I used a break, a mechanically rotating break, which was charging a condenser 5,000 times a second, as I described in my patent Number 645,576 of March 20, 1900.

Counsel

What was the voltage that was generated?

Tesla

The voltage was about 4 million volts.

Counsel

You say you used a break, which I understand to be a rotary spark gap. What was the original source of power?

Tesla

The original source of power was an alternator which I employed regularly there, from which I could get about 30 horsepower in ordinary experimentation. It was a machine of a frequency of about 60 cycles.

Counsel

And that was connected in circuit with the condenser and a gap in the well-known way of your oscillators?

Tesla

Yes.

Counsel

Then you got from that, by means of a rotary gap, about 5,000 sparks?

Tesla

Yes, 5,000 per second, and I transferred [these] to a frequency of 200,000 to 250,000 per second. Pardon me for saying, I had arranged for the Examiner to make this demonstration with a high frequency alternator; but just as the work was pressing I tried it and could not get the necessary tension with it, otherwise I would have used the alternator. But in this other way, I could get the 4 million volts I needed; that is the reason why the experiment was made with this kind of apparatus.

Counsel

And you had a wave frequency of what?

Tesla

Between 200,000 and 250,000. That was simply wave frequency; that did not mean anything here because I was transmitting through a conductor. I was not radiating energy into space.

Counsel

Was that a glass tube?

Tesla

Yes, 2 or 3 inches in diameter, and joined with rubber. Then there was a pipe that led to the pump, and I had a manometer to show accurately the pressure in the tube. I calculated it so that it corresponded to a definite height of about 5 miles. Because I had mentioned in my patent 5 miles, I did not want to retract that statement. It was simply to show that this was practicable.

We shall come immediately to something which will put all this in a different light.

Here [referring to Fig. 79] is the earth. Radio engineers do not realize this truth, but when they do they will immediately get a different view of the whole radio transmission and will design their apparatus accordingly. [I]n fact, they will do exactly what I did. It was a revelation to me.

The earth is 4,000 miles radius. Around this conducting earth is an atmosphere. The earth is a conductor; the atmosphere above is a conductor, only there is a little stratum between the conducting atmosphere and the conducting earth which is insulating. Now, on the basis of my experiments in my laboratory on Houston Street, the insulating layer of air, which separates the conducting layer of air from the conduct-

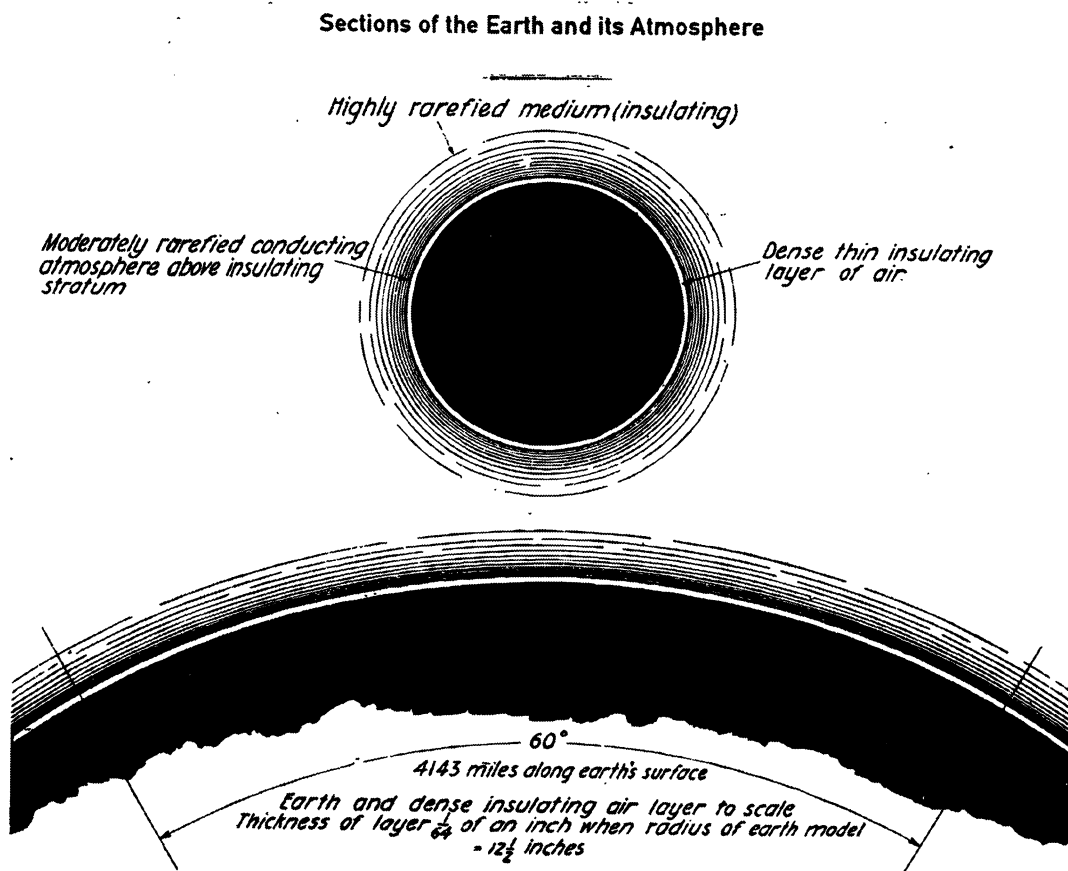

Figure 79.

Diagram explanatory of the transmission of electrical energy by the method described. First put before Lord Kelvin in the Houston Street laboratory, September 1897.

ing surface of the earth, is shown to scale as you see it here. Those [radii lines] are 60° of the circumference of the earth, and you may notice that faint white line, a little bit of a crack, that extends between those two conductors. Now, you realize right away that if you set up differences of potential at one point, say, you will create in the media corresponding fluctuations of potential. But, since the distance from the earth's surface to the conducting atmosphere is minute, as compared with the distance of the receiver at 4,000 miles, say, you can readily see that the energy cannot travel along this curve and get there, but will be immediately transformed into conduction currents, and these currents will travel like currents over a wire with a return. The energy will be recovered in the circuit, not by a beam that passes along this curve and is reflected and absorbed, because such a thing

is impossible, but it will travel by conduction and will be recovered in this [emphasis in original] way. Had I drawn this white line to scale on the basis of my Colorado experiments, it would be so thin that you would have to use a magnifying glass to see it.

Counsel

Will you pardon me for interrupting again. You spoke some time ago about getting all of the energy from your transmitting into your receiving station by this method of yours. I do not understand how you can get all of it.

Tesla

Oh, that is hardly true; I am speaking as a matter of principle. You never can get all the energy, because there is no such thing as perfect apparatus.

Counsel

I did not mean it in that sense. I understand that there is, of course, always some loss, but my conception was that when you created the disturbance in the electrical condition of the earth at your transmitting station, that that extended out in all radial directions.

Tesla

Yes, it did.

Counsel

And therefore how, at any given station, can you get more than a very small fraction of that energy?

Tesla

Pardon me, you are mistaken.

Counsel

That is what I want you to explain. I must be mistaken, because my conception does not fit in with your statements.

Tesla

All right, I will explain that.

In my first efforts, of course I simply contemplated to disturb effectively the earth, sufficiently to operate instruments. Well, you know you must first learn how to walk before you can fly. As I perfected my apparatus, I saw clearly that

I can recover, of that energy which goes in all directions, a large amount, for the simple reason that in the system I have devised, once that current got into the earth it had no chance of escaping, because my frequency was low; hence, the electromagnetic radiation was low. The potential, the electric potential, is like temperature. We might as well call potential electric temperature. The earth is a vast body. The potential differences in the earth are small, radiation is very small. Therefore, if I pass my current into the earth, the energy of the current is stored there as electromagnetic momentum of the vibrations and is not consumed until I put a receiver at a distance, when it will begin to draw the energy and it will go to that point and nowhere else.

Counsel

Why is that, on your theory?

Tesla

I will explain it by an analogue.

Suppose that the earth were an elastic bag filled with water. My transmitter is equivalent to a pump. I put it on a point of the globe, and work my little piston so as to create a disturbance of that water. If the piston moves slowly, so that the time is long enough for the disturbance to spread over the globe, then what will be the result of my working this pump? The result will be that the bag will expand and contract rhythmically with the motions of the piston, you see. So that, at any point of that bag, there will be a rhythmical movement due to the pulsations of the pump.

That is only, however, when the period is long. If I were to work this pump very rapidly, then I would create impulses, and the ripples would spread in circles over the surface of the globe. The globe will no longer expand and contract in its entirety, but it will be subject to these outgoing, rippling waves.

Remember, now, that the water is incompressible, that the bag is perfectly elastic, that there are no hysteretic losses in the bag due to these expansions and contractions; and remember also, that there is a vacuum, in infinite space, so that the energy cannot be lost in waves of sound. Then, if I put at a distant point another little pump, and tune it to the rhythmical pulses of the pump at the central plant, I will excite strong vibrations and will recover power from them, sufficient to operate a receiver. But, if I have no pump there to receive these oscillations, if there is nowhere a place where this elastic energy is transferred into frictional energy (we always use in our devices frictional energy -- everything is lost through friction), then there is no loss,

and if I have a plant of 1,000 horsepower and I operate it to full capacity, that plant does not take power, it runs idle, exactly as the plant at Niagara. If I do not put any motors or any lamps on the circuit, the plant runs idle. There is a 5,000 horsepower turbine going, but no power is supplied to the turbine except such power as is necessary to overcome the frictional losses.

Now the vast difference between the scheme of radio engineers and my scheme is this. If you generate electromagnetic waves with a plant of 1,000 horsepower, you are using 1,000 horsepower right along -- whether there is any receiving being done or not. You have to supply this 1,000 horsepower, exactly as you have to supply coal to keep your stove going, or else no heat goes out. That is the vast difference. In my case, I conserve the energy; in the other case, the energy is all lost.

Counsel

Mr. Tesla, does that not presuppose that the fluid must be incompressible?

Tesla

I should say so, and electricity, whatever it is, certainly it is incompressible because all our experiments show that.

Counsel

Now, if you were giving that a name, what principle would you say was involved by which the radiation loss, where there is no receiver, becomes a gain or a conservation where there is a receiver?

Tesla

There is no radiation in this case. You see, the apparatus which I devised was an apparatus enabling one to produce tremendous differences of potential and currents in an antenna circuit. These requirements must be fulfilled, whether you transmit by currents of conduction, or whether you transmit by electromagnetic waves. You want high potential currents, you want a great amount of vibratory energy; but you can graduate this vibratory energy. By proper design and choice of wave lengths, you can arrange it so that you get, for instance, 5 percent in these electromagnetic waves and 95 percent in the current that goes through the earth. That is what I am doing. Or, you can get, as these radio men, 95 percent in the energy of electromagnetic waves and only 5 percent in the energy of the current. Then you are wondering why you do not get good

results. I know why I do not get good results in that way. The apparatus is suitable for one or the other method. I am not producing radiation in my system; I am suppressing electromagnetic waves. But, on the other hand, my apparatus can be used effectively with electromagnetic waves. The apparatus has nothing to do with this new method except that it is the only means to practice it. So that in my system, you should free yourself of the idea that there is radiation, that energy is radiated. It is not radiated; it is conserved.

Counsel

Right in that connection, and to illustrate your theory, I would like to know whether you consider that the radiation from any wireless station is wasted or conserved, or whether the effect produced by any of them today is due to this conductive action, so far as it is effective.

Tesla

Absolutely -- the effect at a distance is due to the current energy that flows through the surface layers of the earth. That has already been mathematically shown, really, by Sommerfeld. [See editorial note p. 75.] He agrees on this theory; but as far as I am concerned, that is positively demonstrated. For instance, take the Sayville antenna. Professor Zebeck took me out and gave me the particulars. I went over the calculations and found that at 36 kilowatts they were radiating 9 kilowatts in electromagnetic wave energy. They had, therefore, only 25 percent of the whole energy in these waves, and I told Professor Zebeck that this energy is of no effect -- that they produce, by the current, differences of potential in the earth, and these differences of potential are felt in Germany and affect the receiver; but the electromagnetic waves get a little beyond Long Island and are lost.

I have an idea that [you] will get the best picture of the process in my system of transmission if you will imagine that the earth is a reservoir, say, of fluid under pressure -- that is the potential energy -- and at my plant, operating a distant tuned circuit, I must open a valve and enable that energy to flow in. It is exactly that way. The energy is all conserved, whether it is vibrating or purely potential. Whatever the transmitter does in the receiver, the effect is simply to open a valve, as it were, and permit energy to flow in.

Now, of course, the hardest thing to understand, if one is not a specialist in that line and has not spent years, as I have, in experiments and thought in that direction, is how can a plant like that be economically operated when we know that there are mountain peaks everywhere? Those peaks are

antennae; they are likewise charged. Well, it took me a long time to find that out. To give you an idea, let us take a big, enormous mountain like the peak of Tenerife. That is a big mountain that rises out of the sea and goes up to 17,000 or 18,000 feet. Naturally, that is a tremendous antenna, everybody will think. Without calculating, without passing through the experience I have gone through, you will say that peak alone will take away more energy than all the antennae you can put up all over the world. That is not so.

The peak of Tenerife has no more capacity than something like 100 centimeters [110 picofarads], and it will be charged to a very low potential, whereas my antenna could be charged to a very high potential. I can show that the mountain would not absorb much energy, not 0.0001 percent of that my antenna would. I could put my antenna right close to the peak, and it will take 10,000 times more energy.

You must simply realize that the earth is, so far as it is mechanically looked upon, like a rough ball; but when you look at it electrically, it is a polished ball. Lord Kelvin has already, in his papers on atmospheric electricity, of which he kindly sent me two copies -- he did not stop at sending me one -- grasped that; he considered the distribution of electricity on the globe, and came to the conclusion that the capacity of definite terrestrial areas does not increase sensibly with elevation.

You see, the electrical surface density on the highest peaks is not any more than just a fraction of 1 percent greater than on the sea. So that the whole thing, to my mind, appears as a wonderfully providential arrangement, and we can by this means realize things so marvelous that one would be almost afraid to talk about them; and the apparatus -- I do not say that because I am the inventor -- the apparatus is practically the Lamp of Aladdin.

Counsel

Is it because the earth is this inelastic mass of electricity that it is the basis for your statement that distance is of no consequence? That is the way I visualize that it is, that if the earth is an inelastic mass or body of electricity, and you set that mass into vibration at any one point, that vibration will extend to the antipodes equally as well as it will to a distance of 200 miles. Is that what you had in mind?

Tesla

I must first clear away some illusionary ideas. You must first understand certain things. Consider, for instance, the term "resistance." When you think of resistance you imagine,

naturally, that you have a long, thin conductor; but remember that while resistance is directly proportionate to length, it is inversely proportionate to the section. It is a quality that depends on a ratio. If you take a small sphere of the same size of a pea, and compare its length with its section, you would find a certain resistance. Now you extend this pea to the size of the earth, and what is going to happen?

While the length increases, say a thousand times or a million times, the section increases with the square of the linear dimensions, so that the bigger this thing is the less resistance it has. Indeed, if the earth were as big as the sun we would still be better off than we are; we could readily telephone from one end of the sun to the other by the system, and the larger the planet the better it would be.

Counsel

Then do I get your idea correctly, that distance is of no importance because of the low resistance due to the large section of the earth?

Tesla

No, pardon me.

Counsel

I cannot quite get that. Why is it that with your system distance cuts no figure?

Tesla

Distance cuts no figure for the reason that there is no fall of potential. Now imagine this: Suppose that the earth, in reality, were a big main, a main of copper, say, that all the copper of the earth would be fused into a big main, and then you will readily see it would not make any difference where you tapped that energy, whether you do it nearby or whether you go 100 miles further, because the resistance of the main is nothing. The resistance of the earth does not come in in this way, but in another way.

These questions are very complex. The resistance is only at the point where you get into the earth with your current. The rest is nothing. Those things will be very difficult to explain without a lot of theoretical stuff, which would be unprofitable, when it is here the object to give a clear idea of the principle and nothing else.

This [Fig. 80] illustrates one of the fallacies which the questioning has already brought out. Here is, for instance, an attempt to produce a large capacity, an antenna of very

No. 676,332.

Patented June 11, 1901.

G. MARCONI.

APPARATUS FOR WIRELESS TELEGRAPHY.

(Application filed Feb. 23, 1901.)

(No Model.)

2 Sheets—Sheet 2.

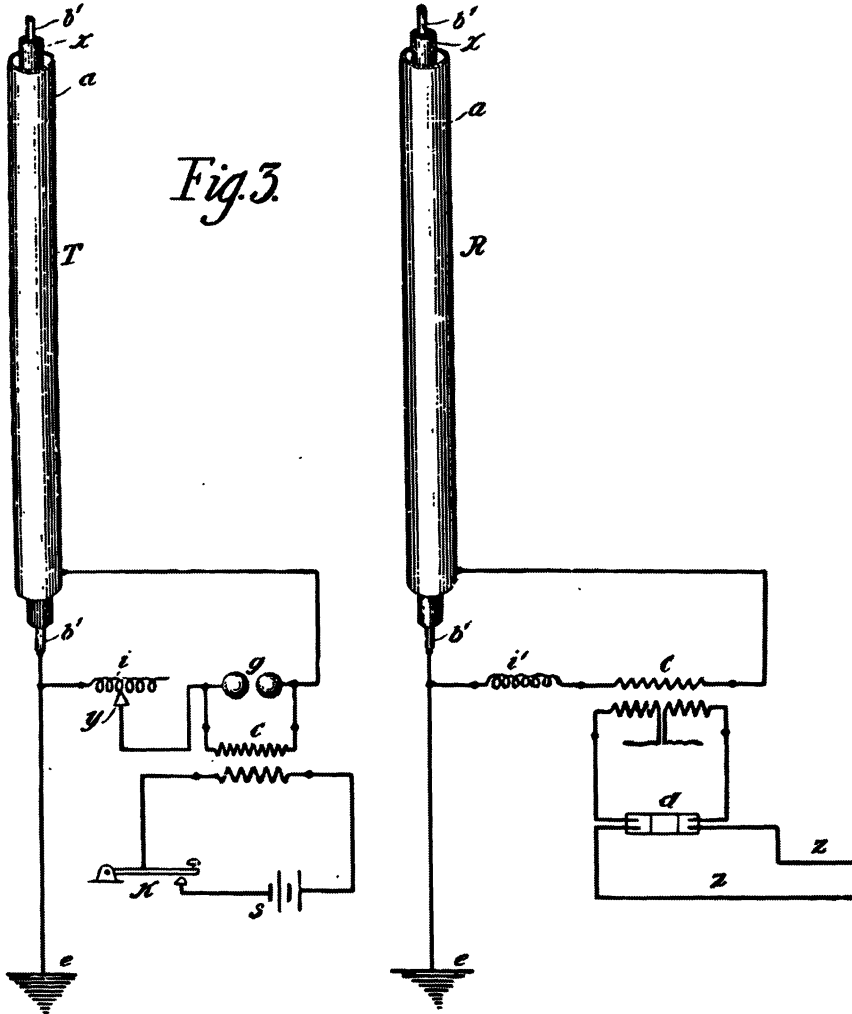

WITNESSES:
Wm. Tallman
Henry Prager

INVENTOR
 Guglielmo Marconi,
 BY
Bate, Bate, & Buffum & Bate
 ATTORNEYS.

Figure 80.
 Diagram illustrating one of the many wireless fallacies,
 taken from a U.S. Patent of Guglielmo Marconi, No. 676,332,
 June 11, 1901.

large capacity, by using two concentric cylinders. I have already elucidated this error, but in a different phase. The capacity between those two conductors has absolutely nothing to do with the capacity which enters into the transmission of the energy to a distance. That is purely and entirely a local flux, simply a means of wasting energy. Such errors as this you will find throughout all the technical literature, but this has already been explained in another way.

[Summarizing,] I have already explained the various steps I have set forth in the introduction to this long talk. I have explained how I produced the apparatus giving the requisite oscillations; the second step how I transformed those oscillations into vibratory energy capable of going to a distance; and, furthermore, how I solved another problem, namely, that of the right wavelengths which are effective in the conduction of energy to a distance.

Before I went to Colorado, the one thing which I needed to find out was, how does the current flow through the earth? In my experiments from Houston Street and around New York, I had already learned that the effect is proportionate to the quantity of electricity displaced, and I was in the position to accurately calculate a plant for transmission, for instance, across the Pacific or Atlantic. Those were simple problems; but I could not yet tell how the current passes through the earth, and until I could do that I could not undertake the design of a plant in all these particulars so that it could be a piece of engineering.

I spent 30 years of my work in the design of machinery of all kinds, and have never yet designed a machine which did not do as I expected, and I cannot imagine why it should not be, because when one calculates the things out on the basis of experimental data, the machine has to work as intended. This is engineering.

Therefore, when my friends offered to back me up for a plant under my patents, I thought it was best to devote some time to an investigation, to find out what I needed, in order to have all my data accurately and guarantee that the plant would work.

The law which I discovered in Colorado is wonderful, and it shows that results undreamed of before and of incalculable moment will be obtained as soon as a plant, embodying these principles, is established on a large scale.

To give you an idea, I have prepared a diagram [Fig. 81] illustrating an analogue which will clearly show how the current passes through the globe. You know that in a solar eclipse the moon comes between the sun and the earth, and that its shadow is projected upon the earth's surface. Evidently,

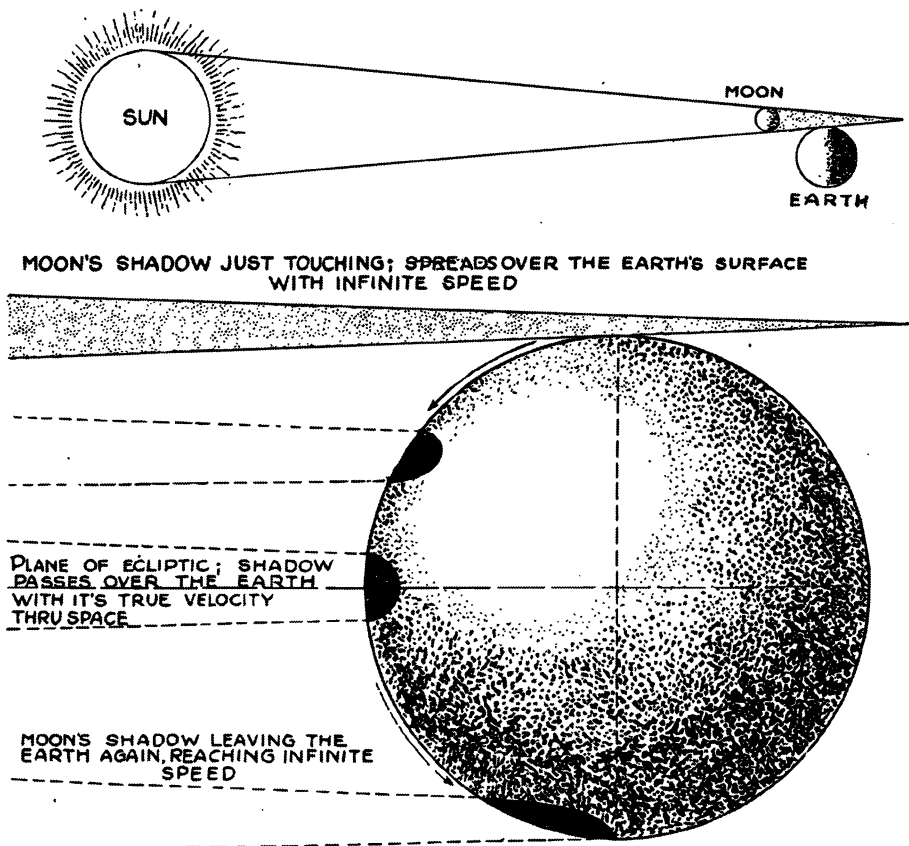

Figure 81.

Diagram illustrating the mode of propagation of the current from the transmitter over the earth's surface.

in a given moment, the shadow will just touch at a mathematical point, the earth, assuming it to be a sphere.

Let us imagine that my transmitter is located at this point, and that the current generated by it now passes through the earth. It does not pass through the earth in the ordinary acceptance of the term, it only penetrates to a certain depth according to the frequency. Most of it goes on the surface, but with frequencies such as I employ, it will dive a few miles below. It can be mathematically shown that it is immaterial how it passes; the aggregate effect of these currents is as if the whole current passes from the transmitter, which I call the pole, to the opposite point, which I call the antipode.

Assume, then, that here is the transmitter, and imagine that this is the surface of the sea, and that now comes the shadow of the moon and touches, on a mathematical point, the

calm ocean. You can readily see that as the surface of the water, owing to the enormous radius of the earth, is nearly a plane, that point where the shadow falls will immediately, on the slightest motion of the shadow downward, enlarge the circle at a terrific rate, and it can be shown mathematically that this rate is infinite. In other words, this half-circle on this side will fly over the globe as the shadow goes down; will first start at infinite velocity to enlarge, and then slower and slower and slower, and as the moon's shadow goes further and further and further, it will get slower and slower until, finally, when the three bodies are on the plane of the ecliptic, right in line one with the other in the same plane, then that shadow will pass over the globe with its true velocity in space. Exactly that same thing happens in the application of my system, and I will show this next.

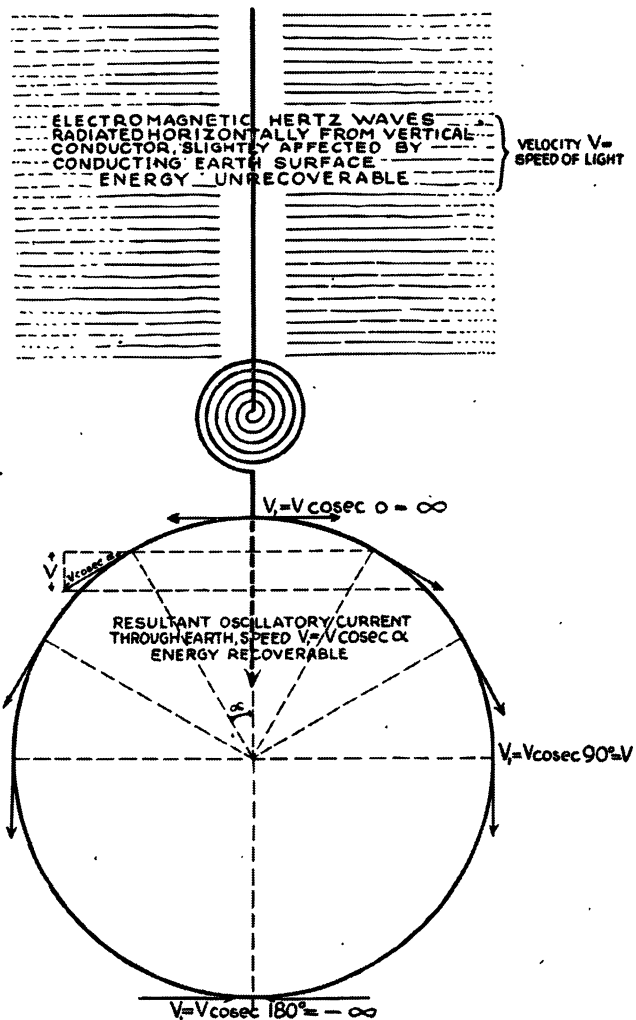

Figure 82.
 Diagram illustrating the law governing the passage of the current from the transmitter through the earth, first announced in U.S. Patent No. 787,412 of April 18, 1905. Application filed May 16, 1900. See also J. Erskine-Murray, A Handbook of Wireless Telegraphy, Chapt. 17, pp. 312-330, 1913 edition, published by Crosby Lockwood and Son, London, and Appleton & Company, New York.

This [Fig. 82] illustrates, on a larger scale, the earth. Here is my transmitter -- mine or anybody's transmitter -- because my system is the system of the day. The only difference is in the way I apply it. They, the radio engineers, want to apply my system one way; I want to apply it in another way.

This is the circuit energizing the antenna. As the vibratory energy flows, two things happen: There is electromagnetic energy radiated and a current passes into the earth. The first goes out in the form of rays, which have definite properties. These rays propagate with the velocity of light, 300,000 kilometers per second. This energy is exactly like a hot stove. If you will imagine that the cylinder antenna is hot -- and indeed it is heated by the current -- it would radiate out energy of exactly the same kind as it does now. If the system is applied in the sense I want to apply it, this energy is absolutely lost, in all cases most of it is lost. While this electromagnetic energy throbs, a current passes into the globe.

Now, there is a vast difference between these two, the electromagnetic and current energies. That energy which goes out in the form of rays, is, as I have indicated here [on the diagram of Fig. 82], unrecoverable, hopelessly lost. You can operate a little instrument by catching a billionth part of it but, except this, all goes out into space never to return. This other energy, however, of the current in the globe, is stored and completely recoverable. Theoretically, it does not take much effort to maintain the earth in electrical vibration. I have, in fact, worked out a plant of 10,000 horsepower which would operate with no bigger loss than 1 percent of the whole power applied; that is, with the exception of the frictional energy that is consumed in the rotation of the engines and the heating of the conductors, I would not lose more than 1 percent. In other words, if I have a 10,000 horsepower plant, it would take only 100 horsepower to keep the earth vibrating so long as there is no energy taken out at any other place.

There is another difference. The electromagnetic energy travels with the speed of light, but see how the current flows. At the first moment, this current propagates exactly like the shadow of the moon at the earth's surface. It starts with infinite velocity from that point, but its speed rapidly diminishes; it flows slower and slower until it reaches the equator, 6,000 miles from the transmitter. At that point, the current flows with the speed of light -- that is, 300,000 kilometers per second. But, if you consider the resultant current through the globe along the axis of symmetry of propagation, the resultant current flows continuously with the same velocity of light.

Whether this current passing through the center of the earth to the opposite side is real, or whether it is merely an effect of these surface currents, makes absolutely no difference. To understand the concept, one must imagine that the current from the transmitter flows straight to the opposite point of the globe.

There is where I answer the attacks which have been made on me. For instance, Dr. Pupin has ridiculed the Tesla system. He says,

"The energy goes only in all directions."

It does not. It goes only in one direction. He is deceived by the size and shape of the earth. Looking at the horizon, he imagines how the currents flow in all directions, but if he would only for a moment think that this earth is like a copper wire and the transmitter on the top of the same, he would immediately realize that the current only flows along the axis of the propagation.

The mode of propagation can be expressed by a very simple mathematical law, which is, the current at any point flows with a velocity proportionate to the cosecant of the angle which a radius from that point includes with the axis of symmetry of wave propagation. At the transmitter, the cosecant is infinite; therefore, the velocity is infinite. At a distance of 6,000 miles, the cosecant is unity; therefore, the velocity is equal to that of light. This law I have expressed in a patent by the statement that the projections of all zones on the axis of symmetry are of the same length, which means, in other words, as is known from rules of trigonometry, that the areas of all the zones must also be equal. It says that although the waves travel with different velocities from point to point, nevertheless each half wave always includes the same area. This is a simple law, not unlike the one which has been expressed by Kepler with reference to the areas swept over by the radii vectors.

I hope that I have been clear in this exposition -- in bringing to your attention that what I show here is the system of the day, and is my system -- only the radio engineers use my apparatus to produce too much of this electromagnetic energy here, instead of concentrating all their attention on designing an apparatus which will impress a current upon the earth and not waste the power of the plant in an uneconomical process.

Counsel

You say radio engineers put too much energy into the radiating part. What, as a matter of fact, according to your conception, is the part of the energy that is received in the

receivers in the present system?

Tesla

That has been investigated. Very valuable experiments have been made by Dr. Austin [*], who has measured the effects at a distance. He has evolved a formula in agreement with the Hertz wave theory, and the energy collected is an absolutely vanishing quantity. It is just enough to operate a very delicate receiver. If it were not for such devices as are now in use, the audion, for instance, nothing could be done. But with the audion, they magnify so that this infinitesimal energy they get is sufficient to operate the receiver. With my system, I can convey to a distant point millions of times the energy they transmit.

Counsel

To illustrate my question, take for instance the energy used at Sayville and the reception of that at Nauen. I want to know whether it is your idea that the reception there is due to the earth currents that you have described or to the radiated energy.

Tesla

It is far more due to the earth currents than to the radiated energy. I believe, indeed, that the radiated energy alone could not possibly produce the effect across the Atlantic. It is simply because they are incidentally sending a current through the globe -- which they think is their current -- that the receiver is affected. The current produces variations of potential at the earth's surface in Germany; these fluctuations of potential energize the circuit, and by resonance they increase the potential there and operate the receiver. But I do not mean that it is absolutely impossible to use my apparatus and operate with electromagnetic waves across the Atlantic or Pacific. I only say that according to calculations, for instance, which I have made of the Sayville plant, the radiated energy is very small and cannot be operative. I have also calculated the distribution of the charge on the antenna. I am told that the Sayville antenna is without abrupt changes of capacity. It is impossible. There are changes even in a cylindrical antenna; but particularly in that form at Sayville -- there are very abrupt changes.

* Editorial note: Lewis W. Austin, Chief U.S. Naval Radio Telegraphic Laboratory (located at the National Bureau of Standards), 1908-1923. Austin's papers discussing radio transmission-reception range are: "Some quantitative experiments in long-distance radiotelegraphy," Bulletin of the Bureau of Standards, Vol. 7 (1911), No. 3, pp. 315-366, and "Quantitative experiments in radiotelegraphic transmission," Bulletin of the Bureau of Standards, Vol. 11 (1914), No. 1, pp. 69-87.

Counsel

What would an engineer have to do to the wireless systems of today in order to produce very little radiation of electromagnetic waves and produce a large amount of these earth currents? What changes would he have to make in the system?

Tesla

He would have to construct and operate the apparatus described in my patents and in my lectures.

Counsel

He would have to get very much more inductance in the system than he has today, relatively?

Tesla

It is just like this: In an enterprise of this kind, you have to start with certain fundamental propositions. If you are to build a commercial plant, the question comes up how much money is it to cost. Now, you go to specify before your capitalists the various parts of the plant, and you will find that your machinery and the aerial structure will cost so much. If your capitalists are willing to go deep into their pockets, you can put up a tremendous antenna because, as you know, as I pointed out in 1893, that the effects will be proportionate to the capital invested in that part; but you will find great limits there.

I designed a plant [Wardenclyffe, referring to Fig. 83] years ago with a large capacity and put it before certain architects. They figured that the antenna would cost \$450,000 and I had to modify my plans. As you see, you are limited by cost as to the size of the antenna; that is, you are limited as to the capacity and, furthermore, you have selected the frequency. In order to lower the frequency so that there would be no wasteful radiation of energy, you have to employ a large inductance. You have to employ a capacity as large as permissible, and you must use a large inductance in order that you may reach the low frequency which is economical.

Counsel

What low frequency is it that is economical?

Tesla

In a patent which appeared in April 1905, the application of which was filed on May 15, 1900, I have enunciated the law of propagation, which I have explained, and have stated that the frequencies should not be more than 30,000 or 35,000

N. TESLA.
 APPARATUS FOR TRANSMITTING ELECTRICAL ENERGY.
 APPLICATION FILED JAN. 18, 1902. RENEWED MAY 4, 1907.

1,119,732.

Patented Dec. 1, 1914.

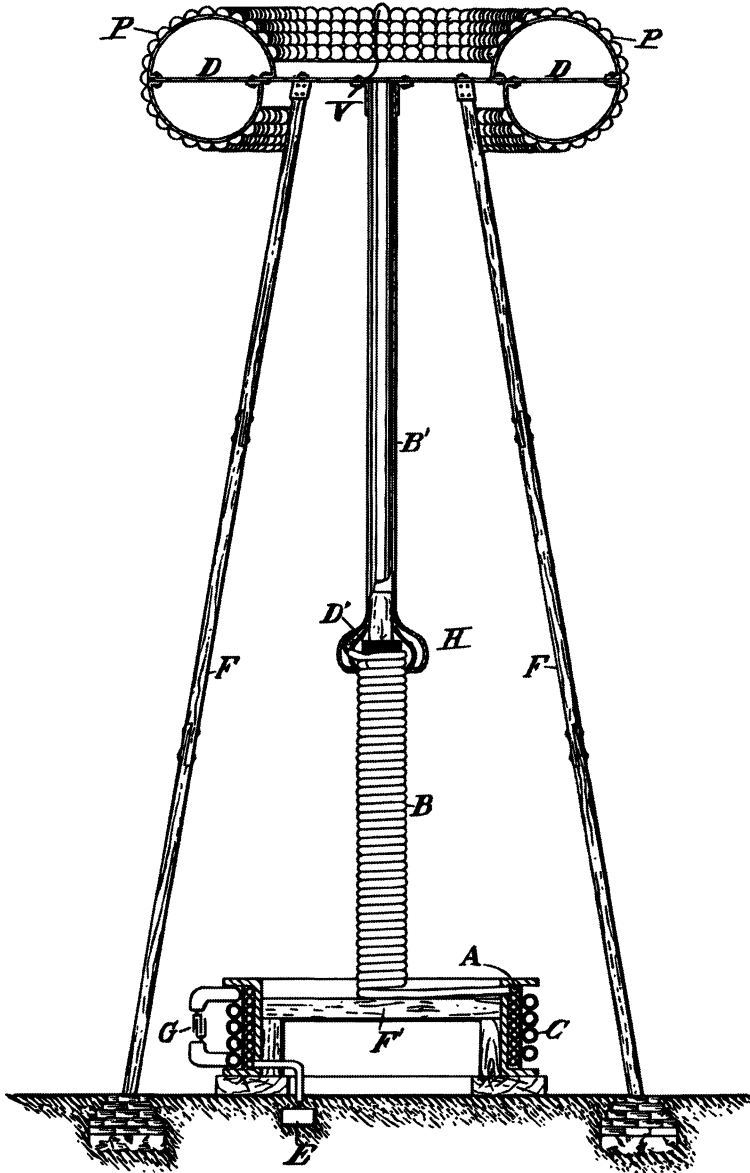

WITNESSES:
M. Lawson Gynn
Benjamin Miller.

Nikola Tesla, INVENTOR,
 BY *Kerr, Page & Cooper,*
 his ATTORNEYS.

Figure 83.
 Improved transmitter described in U.S. Patent No. 1,119,732 of
 December 1, 1914. Application filed January 18, 1902.

cycles at most, in order to operate economically.

Counsel

And would it also be necessary to provide for the high potentials of the order of which you have named in order to insure maximum direct currents and minimum electromagnetic wave radiation?

Tesla

No sir. The currents are proportionate to the potentials which are developed under otherwise equal conditions. If you have an antenna of a certain capacity charged to 100,000 volts, you will get a certain current; charged to 200,000 volts, twice the current. When I spoke of these enormous potentials, I was describing an industrial plant on a large scale because that was the most important application of these principles, but I have also pointed out in my patents that the same principles can be applied to telegraphy and other purposes. That is simply a question of how much power you want to transmit.

Counsel

In Colorado, which did you use?

Tesla

I used the so-called Tesla transformer. I did not have the high frequency machine with which I could develop as much energy for the experiments, but with my transformer I could get any amount of energy I needed. That is why I used the transformer.

Counsel

Tell me what D P stands for [in Fig. 83]?

Tesla

That is a curved plate. The plate has a large radius of curvature. You see, it is to be borne in mind that, in a general way, electricity will accumulate in the same way as the curvature of the surface has a smaller radius. This is an old truth which has been recognized 200 years ago. The design contemplates an arrangement whereby nowhere is electricity accumulated in excess. I am at a substantially uniform distribution of electricity in this structure, not only in the structure, but along the whole circuit where there is a high potential. This, of course, is simply to illustrate the principles. If you design a machine like that [referring to Fig. 83], it will be very much superior to those now in existence,

but I have since that time introduced refinements and can produce very much better results than it would be possible with just exactly that construction.

Counsel

You have spoken of the fact that you could use either the alternator or the transformer, and you have illustrated in this diagram [Fig. 83] a condenser at G?

Tesla

Yes.

Counsel

And stating, I believe, that that represents to your mind any method of getting continuous waves. I think you said, previously, that you actually used either of these methods at Colorado and still had continuous generation.

Tesla

Yes.

Counsel

Was the method you used there [in Colorado], a spark? -- an arc? -- or what was the method where you got continuous generation?

Tesla

The method was this: I had a 550-volt current with which I charged the condensers. These condensers I discharged through a primary in the form of an arc, sometimes I also introduced in this arc a mechanical break of several thousand per second. And I obtained a perfectly continuous train of waves as has been described in my patents. The reason why I show the condenser here [Fig. 83] is that that is synonymous with undamped waves. If I had shown the whole apparatus as arranged there, then I might still have damped waves; but whether I use an alternator or some other way of getting energy to that condenser, the condenser is usually there. For instance, if I use an alternator, I shunt its terminals with a condenser in order to magnify the current in the primary. I then tune this circuit to the alternator, and magnify the current in the primary in the ratio of the inductance to the resistance. Therefore, this condenser here stands for either method, and simply means that in this system, as is obvious from the description in the patent, the waves are undamped because high rises of potential would not be obtained otherwise. Whenever I wanted to obtain a high potential, I had to

observe these rules in order to force the potential up to that value.

VIII. Long Island Plant

Figure 84.
Transmitter at Wardencllyffe, erected in 1901 for purposes of "world telegraphy." (Long Island Plant)

Counsel

How high was that [referring to Fig. 84]?

Tesla

That was 187 feet high.



Figure 85.
View of the plant. (Long Island Plant.)

This [referring to Fig. 85] was started in 1901 and finished in 1902. [*]

Counsel

When were the designs prepared for it?

* Editorial note: For comments on the Long Island plant appearing in earlier sections, see pp. 60, 64, 81, 109, and 112; in later sections, see pp. 159, 170, 172, 173, and 179. Also refer to Appendix II for Tesla's description of the Long Island plant and inventory of the installation as reported in 1922 foreclosure appeal proceedings.

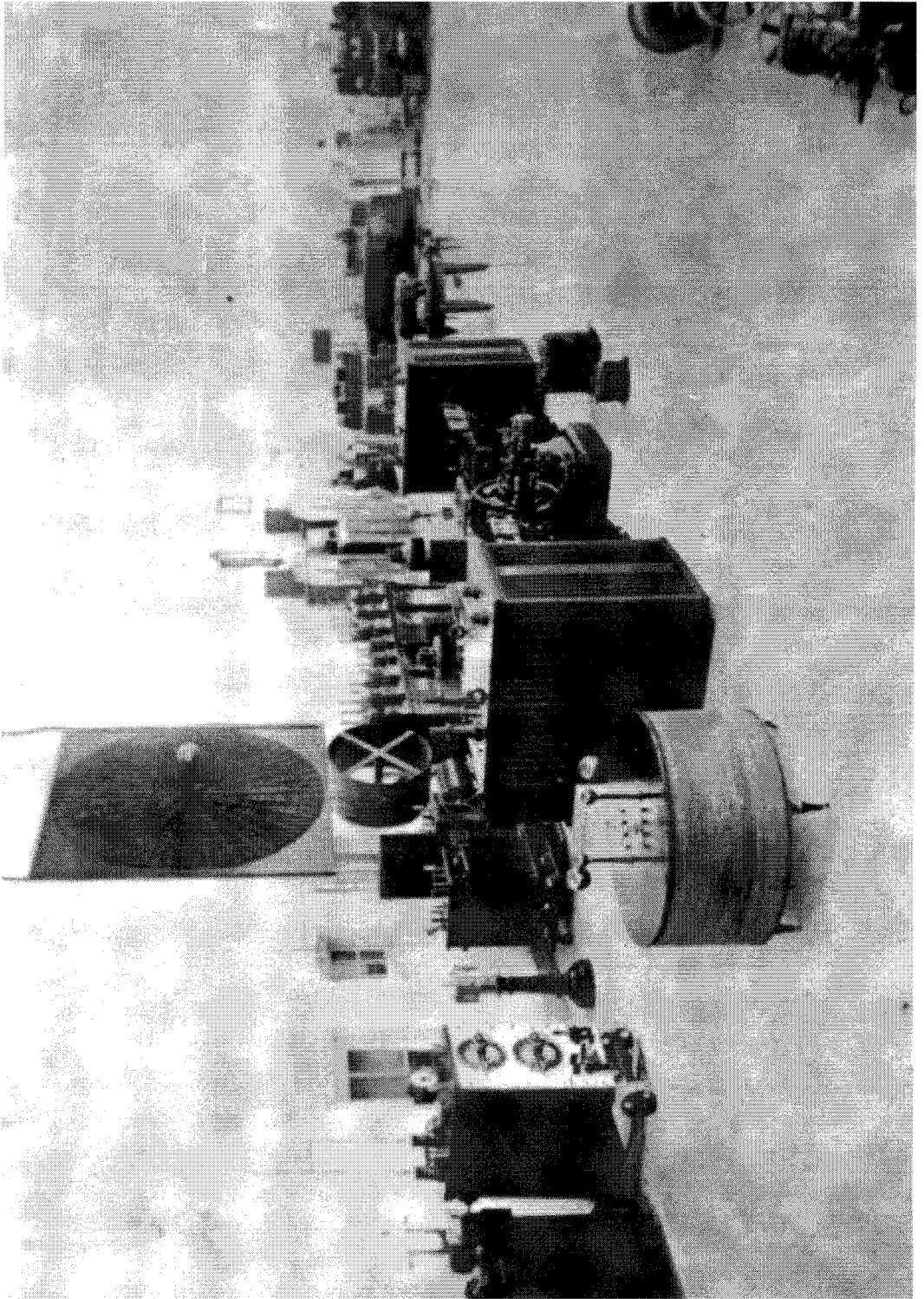

Figure 86.
A view of some of the apparatus in the electrical part of the plant.
(Long Island Plant)

Tesla

In 1900. [Fig. 85] shows the power plant and there is the antenna behind. The distance [of the tower] from the building is 350 feet. That is the smallest distance practicable because I calculated that the spark might jump from the antenna to the chimney, and it was necessary to take a precaution. The distance was indispensable on account of the potential which I was to develop.

This plant was built for wireless telephony. There [Fig. 86] is a view of some apparatus in the plant which you will presently recognize, which I have described. That [at top] is the spiral coil which you have seen previously and which has been illustrated in my patents. This is the instrument which I had before the New York Academy of Sciences and which I have shown previously. And there is the coil, you see, which was moved all around and which I used as a tuning table, and then there are other things.

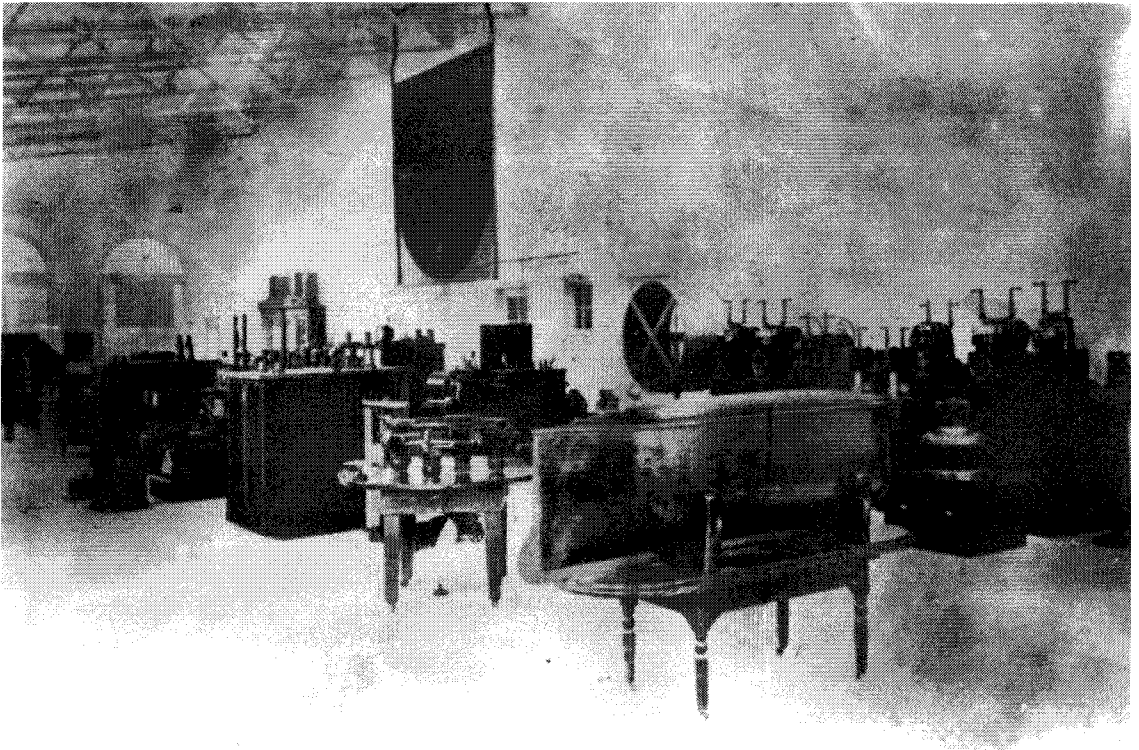

Figure 87.

A view from a different direction. (Long Island Plant.)

There [Fig. 87] you see the same apparatus again. The spiral coil very plainly seen, suspended from above. Here is a telautomaton. These are mercury interrupters, you see how many there are all around here. Here is the mercury interrupter of high frequency in which I had 25 rotating arms and 24 streams to break. That was much used in high frequency work. Here, you see, is the variable inductance and the condenser tanks; these are resistances which I used for reducing the currents to any value desired.

Counsel

When were these photographs taken?

Tesla

These were taken sometime in the summer of 1902. We had just whitewashed these walls and it occurred to me to take a snap of the shop as it was and that is the reason why they were taken. No particular purpose, but they come in here in this connection because they show apparatus which I have described previously and which was constructed from 1896 to 1898, or in that period.

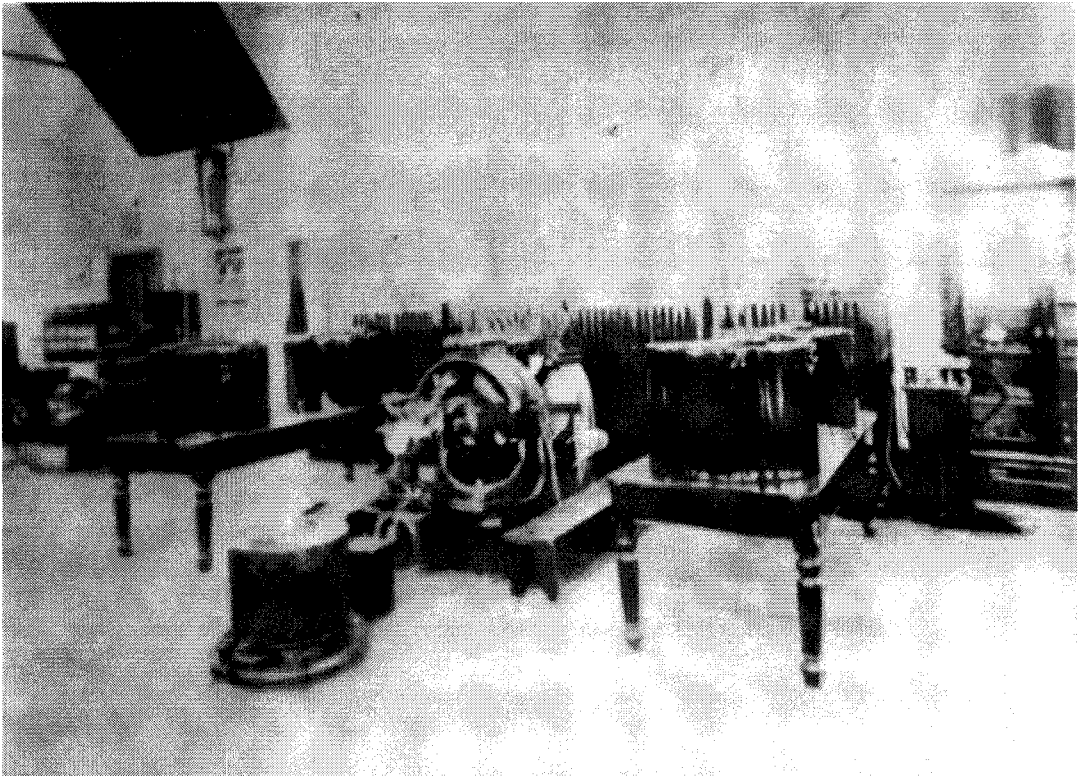

Figure 88.
Another view. (Long Island Plant.)

This is the machine [Fig. 88, center] which transforms the alternating into direct currents of high tension. These are the aluminum plates, wires, and connections. That is the commutator which commutates the alternating current of 11,000 volts, joined in series so that I get 44,000 volts of direct pressure to charge the condensers.

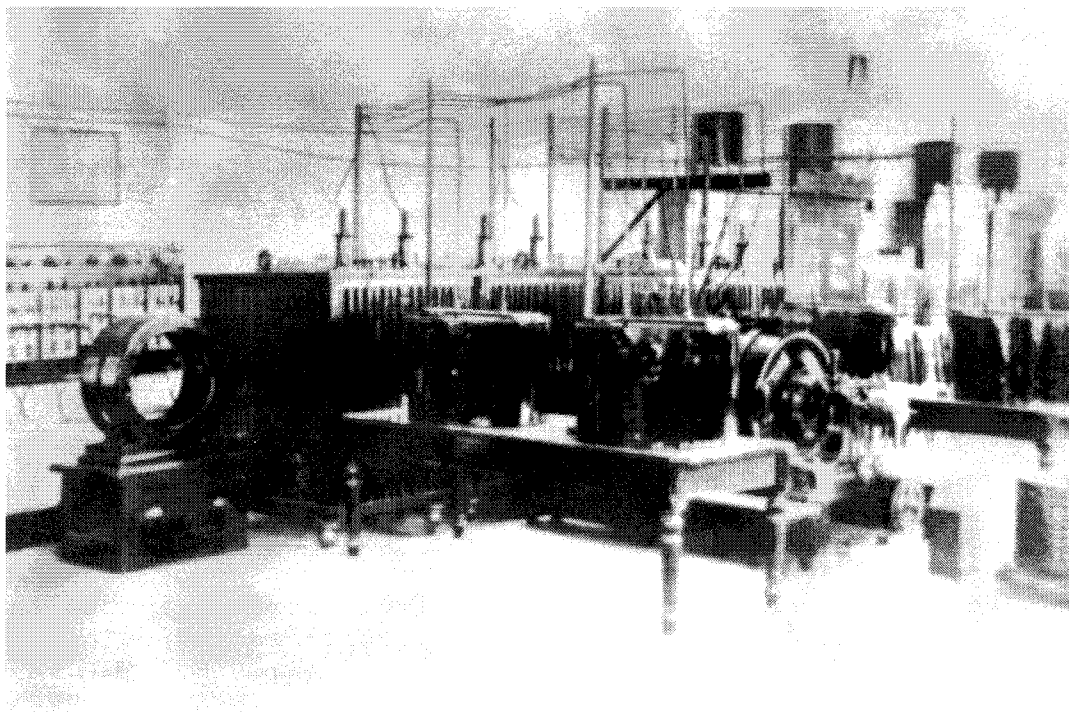

Figure 89.

Another view showing some of the apparatus which has been described. (Long Island Plant.)

Here is [referring to Fig. 89] that high frequency transformer, you see; and here, the apparatus for transforming which I have already shown. There are the four phases, or four transformers, of this apparatus which furnish continuous pressure of 44,000 volts. The condensers from which I obtained undamped waves are, however, not shown here.

Counsel

This Wardencllyffe station was what -- experimental?

Tesla

No, it was a commercial undertaking, but it required so much money that I found impossible to realize it.

Counsel

When was it abandoned?

Tesla

It is not abandoned today. I always hope. It is practically abandoned, yes.

Counsel

I mean, abandoned in the sense of no human beings being there.

Tesla

I tried to keep some human beings there but the bill nearly broke me up.

Counsel

When did this work stop?

Tesla

I would occasionally go there and make some measurements, until recently, about two years ago. The last two or three years I have been doing work in the city because at that plant it was very expensive. It would cost \$100 to run it one day. That was a project which required a great deal of money.

It is too bad that some wireless men did not have the technical ability and experience to enable them to make a success from the start as I would have made. They tried and tried. You take for instance, Marconi -- four times in succession he built a plant.

Counsel

I understand the situation. Was the power ever turned into this antenna at Wardencllyffe? Did you use it in that sense?

Tesla

Oh yes. I used the antenna. I used it right along up to 1907. I made my measurements and experiments, and I transmitted for the purpose of tests, energy and all that, but it never went further than is shown in the picture [Fig. 85]. Several times I spent \$1,000 to paint the thing up, and that paint in a little while was off again.

Counsel

And these times, when you turned the power into the antenna for experiments, what frequencies did you use?

Tesla

I could operate from very low frequencies, from 1,000 cycles on -- to 100,000, 150,000, or 200,000. I had every facility to operate with the lowest frequencies up to the highest.

Counsel

How did you get those frequencies?

Tesla

The low frequencies I usually got from an alternator, and then with this other apparatus the higher frequencies.

Counsel

At what frequencies did you actually operate?

Tesla

I operated according to the nature of the experiment, as I say, from very low frequencies up to 100,000, but most generally I operated with the frequencies which I explained in my patent, say up to 30,000, which I have found to be most economical.

Counsel

What was the nature of those experiments you were making there?

Tesla

The experiments were telephonic, telegraphic demonstrations, measurements of energy, and all that.

Counsel

Was there any receiver station built in connection with this Wardencllyffe apparatus?

Tesla

No, except that I used transportable apparatus with which I made my measurements and received.

Counsel

I have here a small book entitled "Experiments with Alternate Currents of High Potential and High Frequency," containing a lecture delivered by you before the Institution of Electrical Engineers, London, 1892, with an Appendix on the "Transmission of Electric Energy Without Wires," published by McGraw-Hill Book Company, New York, 1904. You are, of course, familiar with it.

Tesla

I have been told this book existed. I cannot remember that I ever had it in my hand. I know it was published, and without my permission, so far as I recollect. As regards the Appendix beginning at page 149, that is really my article that appeared in the Electrical World and Engineer, March 5, 1904, pp. 429-431.

IX. Arrangements for Receiving.

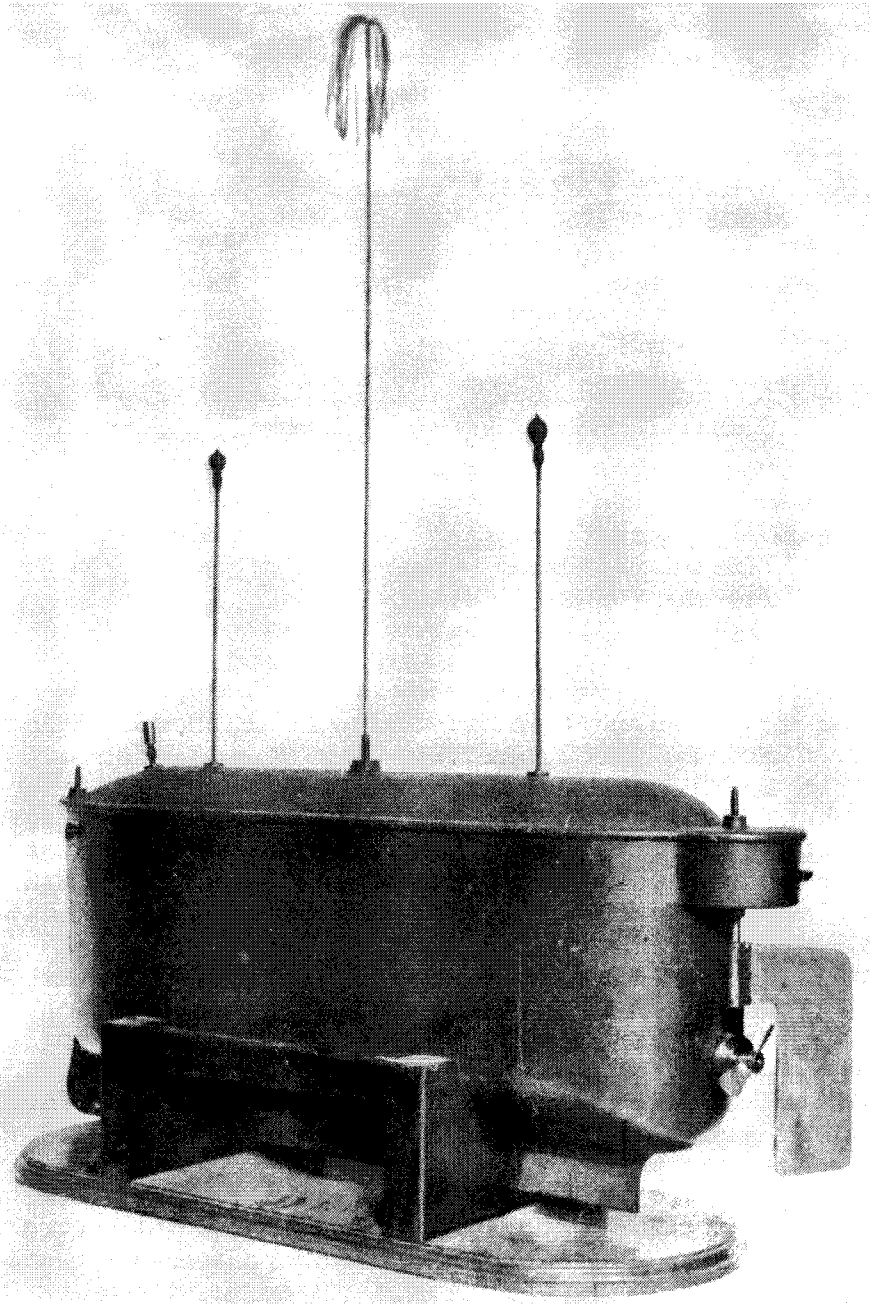

Figure 90.

The first practical telautomaton built on principles described in U.S. Patent No. 613,809 of November 8, 1898. Application filed July 1, 1898. (Article, "The Problem of Increasing Human Energy," Century Magazine, June 1900, Fig. 2, p. 185.)

Tesla

Now I come to the arrangements for receiving. This invention [Fig. 90, overleaf] is one in which I applied certain principles for the first time. This has been called since the "telautomaton." It is described in my article in the Century Magazine of June 1900 and also in my patent No. 613,809 of 1898. The idea was to control a mechanism such as a boat, an airship, or anything you like, from a distance without wires, and in this and in other machines I constructed I applied a certain principle that has been since designated as the principle of individualization. I had it embodied in this boat.

That boat was shown publicly in New York and it was at one time the wonder of the city. I usually would let any person ask some questions, a mathematical operation, or anything else. For instance, somebody would ask, "What is the cube root of 64?" The boat would answer, "4." Anything that I could answer the boat answered. My visitors were puzzled. I would open it and show that there was no one inside; it was just a little box filled with instruments. Some military men told me that the invention was not practicable because I would have an awful lot of machinery, and they had no space for such machinery at all; so, I made this boat only 3 feet long, and in this space I put all the apparatus that was necessary to perform innumerable operations at my command.

I tried to persuade the Navy. I put it before capitalists with a view of introducing it, but it was absolutely impossible to find listeners until my patent expired, and now Congress has appropriated \$750,000! My patent has expired -- I get nothing, and a much smarter radio man [*], but of much lesser experience than my own, is to get \$750,000. I wish him luck. But, still, I ought to have had something, I believe.

The photograph [Fig. 91] shows an instrument which I have used, and which I proposed to use in a practical industrial plant. It was brought before the New York Academy of Sciences; that is, a description of it was given before that scientific body at a meeting in 1897, to which I have previously referred. The lecture was not published because I had to do a lot of things. I had undertaken an extensive program, and I found that my energies were not adequate to the task. Later on, the subject was neglected; other business prevented me from doing anything else, and so my lecture was not published. It only exists in typewritten form, uncompleted. This was not the only lecture of mine that has met with this fate.

* Editorial note: Reference is to John Hays Hammond, Jr.

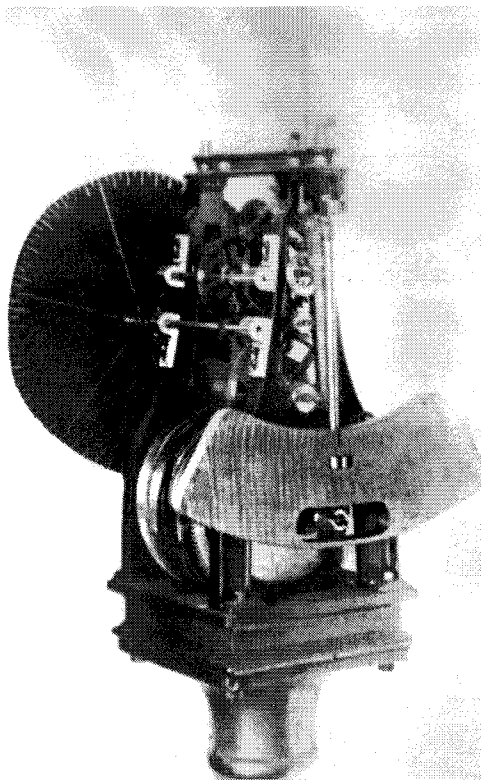

Figure 91 (left).

Special clock constructed for purpose of measurements, especially useful in receiving. Described in lecture before The New York Academy of Sciences, 1897.

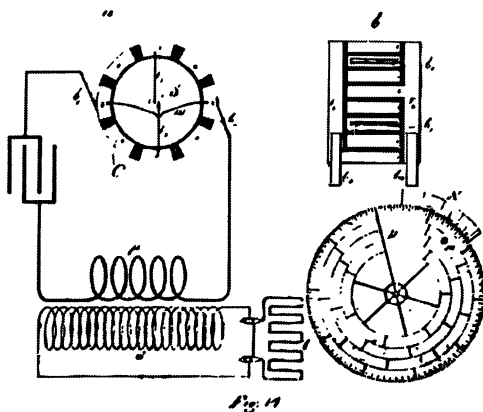

Figure 92 (above).

Illustrating some of the attachments and mode of using same. Houston Street Laboratory, 1898-1900.

The construction [of the instrument] was intended to produce an absolutely constant rotation so that certain intervals of time could be definitely fixed, and in relation to these intervals of time I could analyze the waves. This I used in many of my experiments. Later, I brought it to the Long Island plant, and you have seen it in a picture among other apparatus I had there. This apparatus was employed by me from 1896 or 1897, right up to 1904 or 1905.

These [referring to Fig. 92] are some of the tikkers -- or what do you call them now? I have been capable of inventing these things, but I am incapable of giving them a name. I mean the tone wheel, tikker, and all such devices. You see, I had a shaft which was rotated at a perfectly uniform speed; I could attach to it any kind of device and depend on the synchronism, and in this way indeed I have obtained very fine results in determining quantities of moment in the installment of the commercial plant [on Long Island] which I had undertaken to construct. The bottom of the diagram shows vacuum tubes designed for very minute currents. They were excited by the secondary of the transformer and illuminated the dial. If I used, for instance, two vibrations of different wavelength, then there was a beat, and I would notice, as this disc rotated, the marked lines travel one way or the other. When perfect synchronism was obtained, these lines appeared stationary. I exhibited this instrument during the lecture I delivered before the New York Academy of Sciences.

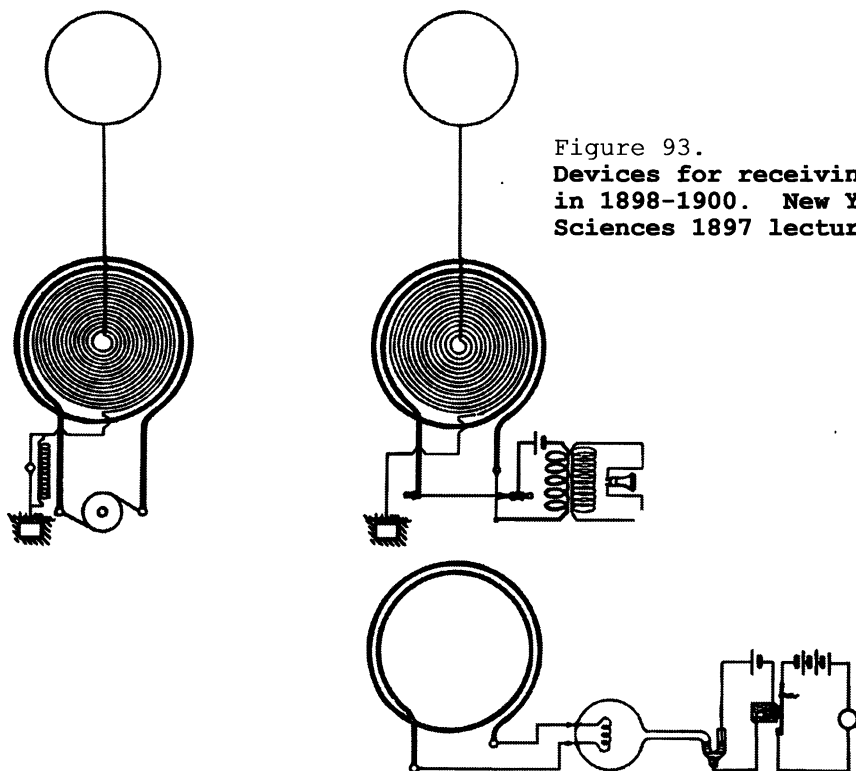

Figure 93.
**Devices for receiving as practiced
 in 1898-1900. New York Academy of
 Sciences 1897 lecture.**

I am now showing [Fig. 93, top] a [drawing of a] device for telephonic and telegraphic signals I have used in my laboratory on Houston Street and also on Long Island. That [left] is a transmitter arranged in the usual way, and this is an inductance which is bridged by a device such that by speaking into it, or actuating it by hand or otherwise, variations in the intensity of the waves are produced.

On the receiver side [right] I have my antenna and self-inductance coil connected to the ground, and in the secondary I have a wire which is under a tension. Another wire, likewise under tension, controls two microphonic contacts or carbons. The tension of this wire is adjustable, and as I will show in another drawing, I can regulate the pressure of the contacts so that a certain current from a battery, here, will flow through this primary coil.

When the transmitted oscillations are controlled and produce corresponding variations in the intensity of the received effects, then the current generated in [the secondary of the receiver] heats that wire more or less and the alternate heating and cooling of the latter results in periodic expansions and contractions vary[ing] the microphonic pressure of the contacts in obedience to the changes produced in the transmitter. In the secondary [of a transformer], I have a telephone

[receiver] specially wound to reproduce the speech. This is a very good device; I have used it with success in my laboratory on Houston Street very frequently. It was [a] very good device. It repeated telephonic speech very nicely.

Counsel

When was that published, and where?

Tesla

That was not published, but that is a drawing of 1899 or 1900. [It] is taken from a drawing for a patent which was not applied for on account of pressing business. I have hundreds of inventions which I could not take the patent on, on account of my misfortunes. I have described this invention only in its simplest form. It was sometimes more complex.

I had numerous arrangements for attunement and magnification in this connection; this [Fig. 93, top] just illustrated the broad principle of heating a wire, changing the pressure of a microphonic contact thereby, and inducing in a telephone [receiver] changes corresponding to those in the transmitter produced by the human voice, or in any other way.

Counsel

When you used that apparatus in your laboratory on Houston Street, where were your transmitter and receiver located?

Tesla

My transmitter was on Houston Street and I would take the receiver with me. For instance, I would take a few toy balloons, go on the roof, and then put my box there with the instruments and listen to the signals.

This [Fig. 93, bottom] is another [drawing of a] device which I also used with success, but not telephonic. It operated on the principle of the Reis air thermometer. This is a bulb, you see, and in the bulb is a resistance wire which is heated and cooled, owing to the fluctuations of the received currents. The attendant expansions and contractions of the air operate a little mercury column, pushing it back and forth. Curiously enough, for receiving telegraphic signals, this crude instrument was certainly good, but of course it was not suited for telephonic reception.

That [Fig. 94, overleaf, top right] illustrates a device which has already been discussed [i.e., the instrument shown in Fig. 13]. I have used it very frequently. This is also a drawing of the period of 1898 to 1900 and illustrates a way of producing audible notes by reaction of the received impulses

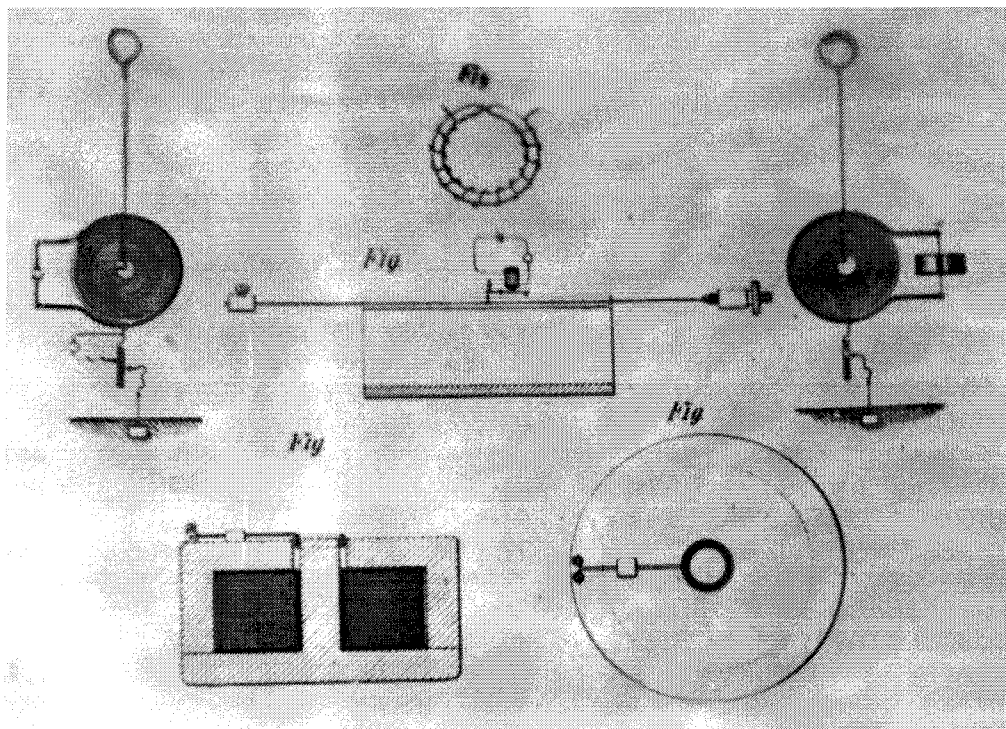

Figure 94.

Other ways of receiving practiced in 1898-1900. New York Academy of Sciences 1897 lecture.

upon a magnetic field. Here [left] is a transmitter, diagrammatically represented, with an arrangement for varying the intensity of the waves emitted, and on the receiver side I have, as you see, a grounded antenna. [The] secondary [has a conductor under tension in] a very powerful magnetic field, and [the reaction of] this conductor, traversed by the received currents in the field, causes the conductor to emit audible notes.

I had several magnets of various forms, like this, and employed a cord in the field, which, when the current traversed it, vibrated and established a contact. Or, I used a small coil like this one here [Fig. 94, top] through which the current was passed, and which by its vibrations produced the signal, an audible note, or anything else I desired.

Counsel

Where was that patent drawing published?

Tesla

That drawing was not published. It is exactly the same thing as the other, but in my writings, which I have before commented upon, I had already shown the reaction of the high

frequency and low frequency currents on magnetic fields, and had specified the frequencies within which one has to keep in order to receive efficiently audible notes.

Counsel

This drawing, however, was actually made about when?

Tesla

From 1899 to 1900. The date of these drawings we can easily locate from the bills I have received.

Counsel

And the devices shown here, were they ever used by you?

Tesla

I used them, of course, frequently. That is, in fact, one of the best forms, but as far as the principle of the employment of the magnet is concerned, it is not novel. The only novel thing was that I used my own discovery, which I had made known in my writings before. I was the first to use high frequency currents reacting on a magnetic field and producing audible notes through the reaction. I employed here only what I described in my lectures. It was a logical application of the principles which I then set forth.

Counsel

Is it one of the forms of receiving instrument which you employed in noting the effect of the signals or waves sent out from Houston Street and in Colorado?

Tesla

Yes. although in Colorado I had some devices a little different. I had a great many of them.

Counsel

Is that drawing [Fig. 94] a part of the patent application or intended for an application?

Tesla

Yes, but it was never filed.

I have a few more photographs here [Figs. 95-100]. The drawings from which they were made have been exhibited on the wall at that Academy of Sciences lecture in 1897. Here I show a great variety of bulbs I used.

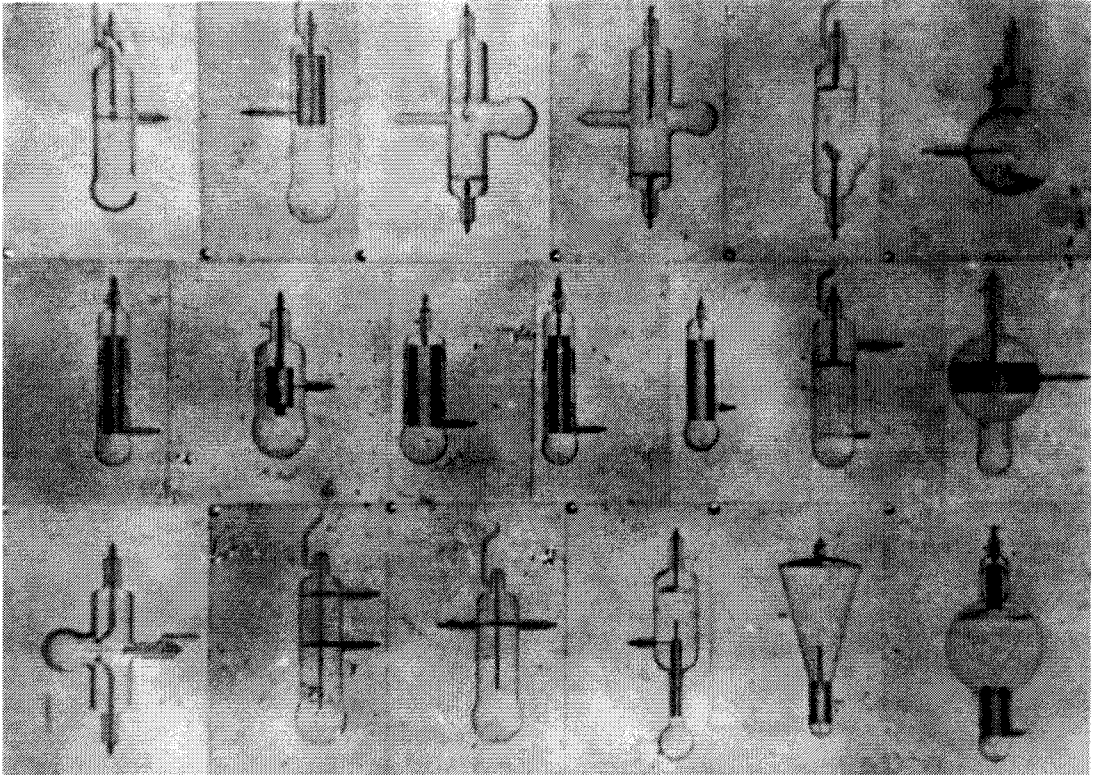

Figure 95.

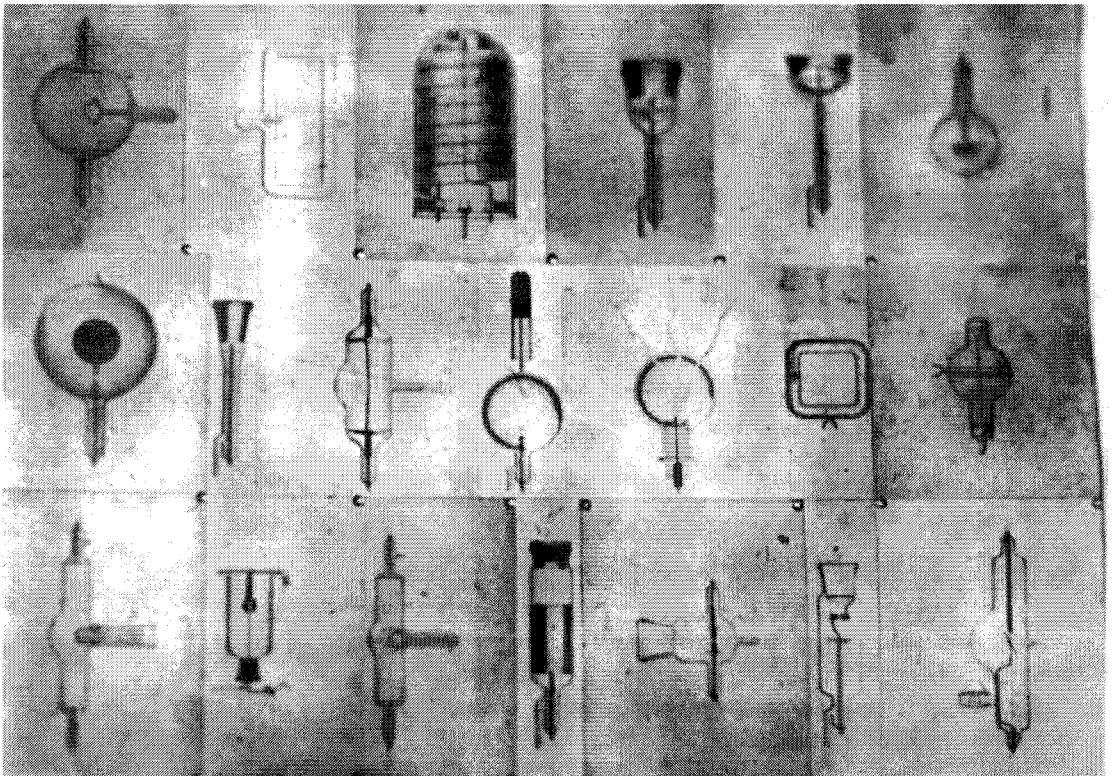

Figure 96.

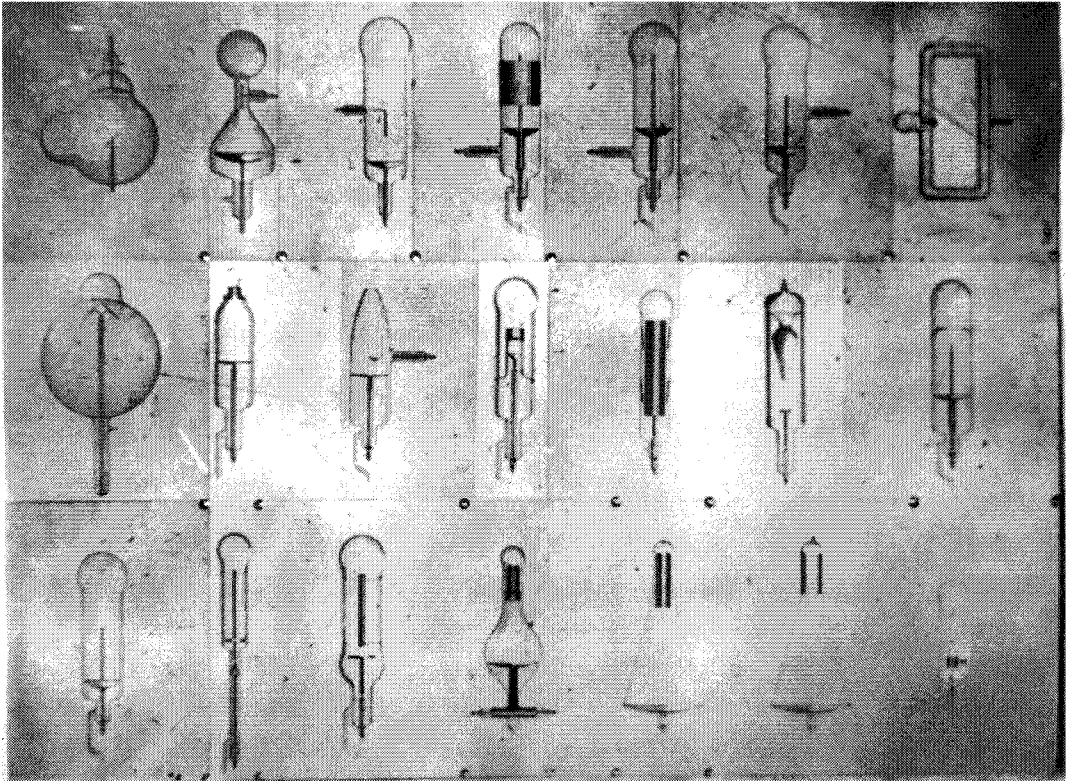

Figure 97.

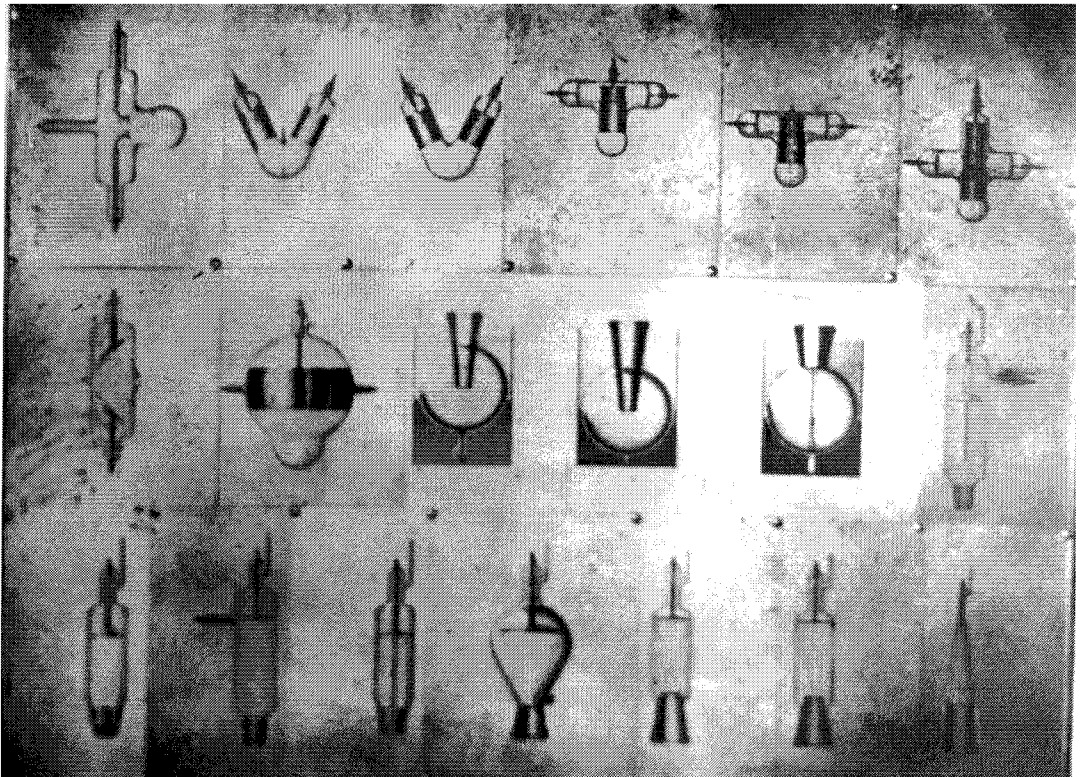

Figure 98.

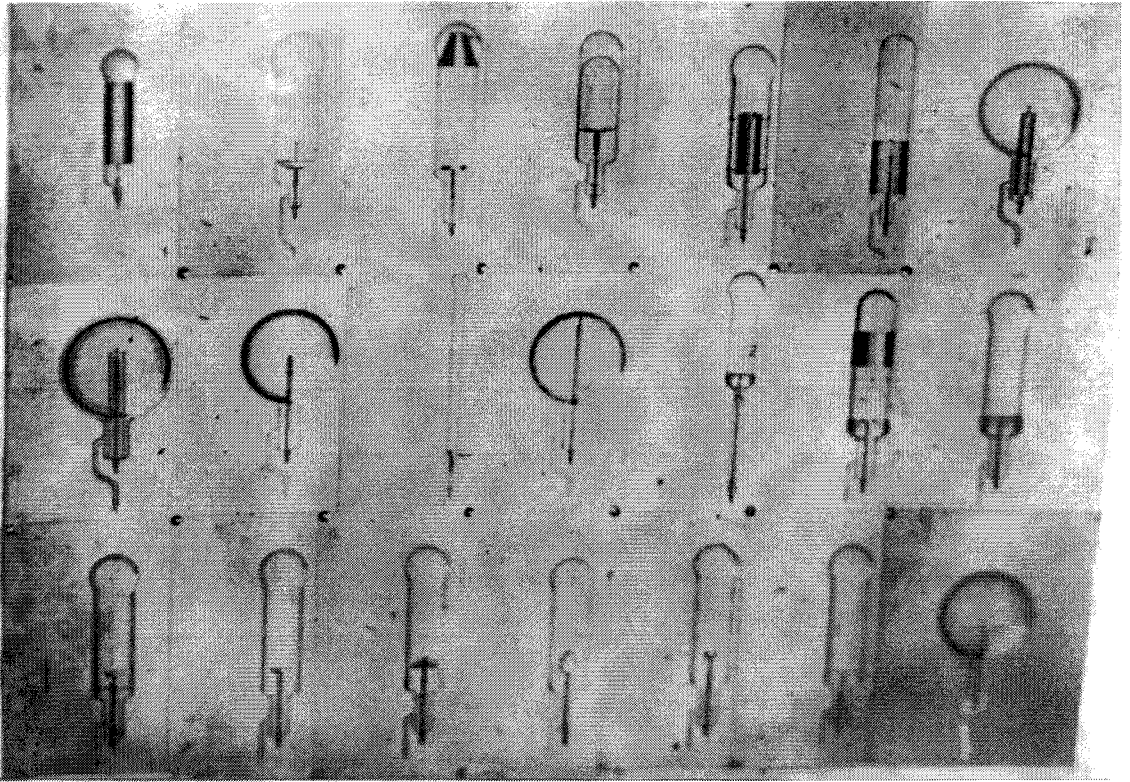

Figure 99.

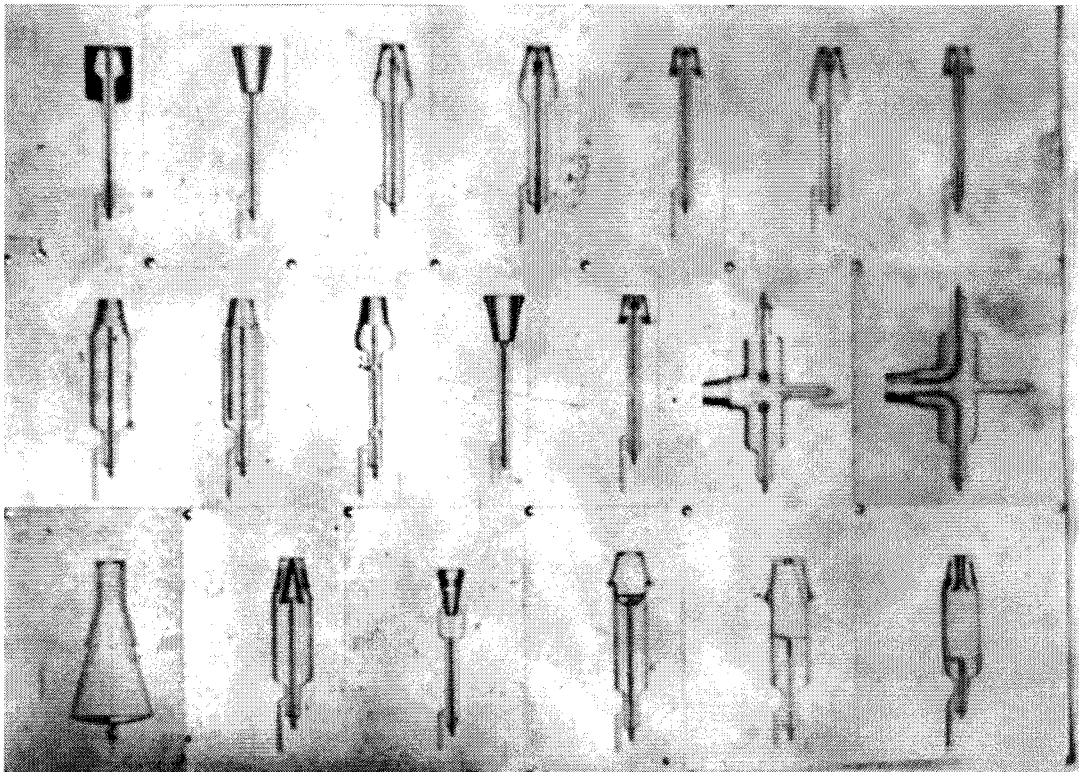

Figure 100.

Figures 95-100 (pp. 164-166).

Illustrating bulbs made prior to 1900, many of which were used in receiving and exhibited in a lecture before The New York Academy of Sciences in 1897.

Every one that you see was built, not in one, but in several forms; they have been experimented with and records have been obtained with them. Among these bulbs I have a great number of receiving devices, and some of them come remarkably close to those which others have used since.

Counsel

In what form has the principle of these bulbs been used by others, as you stated?

Tesla

Well, in some of these bulbs I have shown, for instance, that a heated conductor emits a stream of ions, or, as I said at that time, charged particles, and a few of these bulbs I have been using exactly in the same manner as the audion is used today.

This instrument [Fig. 101] was built [at] a recent date, but the principle involved in its operation I have employed in Colorado. It is what I call a static preventer. A great trouble, when I came to Colorado, was that I could not operate at all. You know that the static interference is today the great bane of the wireless transmission. The reason for that is defective construction of the plants, but with this invention I am enabled to even make these defective plants operate satisfactorily.

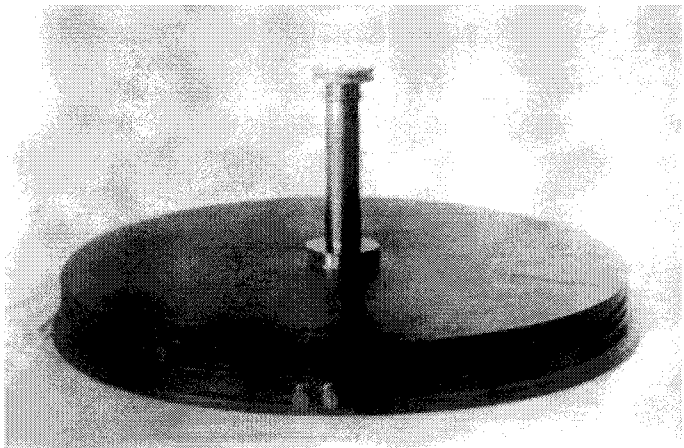

Figure 101.
Static preventer.
(Colorado station.)

The principle involves the employment of a plurality of tuned circuits in series as shown [in Fig. 77]. However, any interaction of the circuits, arising from mutual induction, produces results which are exceedingly complex. The emitted note will not be pure because of the beats produced. Radio engineers are not fully appreciative of this. The instrument shown [Fig. 101] consists of coils suitably arranged in demonstration of the principle to overcome the detrimental effects.

X. Rediscussion/Clarification of Selected Remarks.

Counsel

Suppose a system of radio telegraphy involving a source of low frequency sustained electrical oscillations, delivering its current to an antenna of large capacity, tuned to the frequency of the current delivered to it, and a key or switch delivering such current of such antenna at will for signaling. Did you ever construct a sending installation involving these conditions?

Tesla

Why, in almost any of the experiments of sending installments I made, those were the normal conditions. I have already shown that, in order to operate efficiently, I had to employ a low frequency and sustained oscillations. Furthermore, as regards the capacity, I have also pointed out that I made this capacity as large as was possible under the circumstances.

These sustained oscillations were obtained in the various ways I have explained, either from a high frequency alternator or by my methods of energy transformation of ordinary currents into sustained waves of high frequency, or higher frequency than normal.

Counsel

Will you name two or three installations which embody those conditions?

Tesla

I may name four instances in which those installations were made, operated in exactly the manner described. I operated from my laboratory at 35 South Fifth Avenue, where I would usually run one of my high frequency dynamos, connected either directly or through a secondary, to the antenna on the roof, and as a receiver station I would have a tuned circuit with some devices, usually telephonic, for receiving the signals. The signals were given either in a predetermined order, by an automatically rotated switch, or I asked an assistant to operate the switch according to my instructions.

The receiver plants were usually on some other buildings in the city; most generally, as I stated, I operated between 35 South Fifth Avenue and 28th Street at the Gerlach Hotel, where I was stopping.

In my laboratory on Houston Street, I had a similar installment, using an antenna on the roof and either a high

frequency alternator or my transformer as a source of undamped waves or continuous oscillations, and I operated similarly tuned receiver circuits at other distant places, among others, West Point, which was the farthest distance I ever used the transmitter, [and] which gave results enabling me to calculate the performance of a larger plant, which I was then planning.

In Colorado I erected a plant for the practical purpose of arriving at accurate data for the construction of a large plant which I have termed a universal relay, or some such words. The plant in Colorado was merely designed in the same sense as a naval constructor designs first a small model to ascertain all the quantities before he embarks on the construction of a big vessel. I had already planned most of the details of the commercial plant, subsequently put up at Long Island, except that at that time the location was not settled upon. The Colorado plant I have used in determining the construction of the various parts, and the experiments which were carried on there were for the practical purpose of enabling me to design the transmitters and receivers which I was to employ in the large commercial plant subsequently erected.

In Colorado it was my practice to operate either with a perfectly sustained wave produced by my methods, which I have already described, from a 550-volt current which I attained from the street railway mains, or else I used sustained waves produced in other ways, which I have already described.

Now, these impulses of the transmitter were controlled either by a controller or by an assistant, and the signals were received by me in portable instruments which I took out occasionally and with which I made measurements and observations.

Then, on Long Island, during the construction of that plant, and when the antenna was already placed in position, I used the antenna in similar experiments and demonstrations while the work was going on. I had, however, other provisional antennae in the meantime which I used before the big one was erected.

Counsel

Earlier you spoke of the lack of isochronism in the frequencies of the rotary alternators or sources. How did that lack of isochronism compare with alternators of the present day that are used for service of this kind?

Tesla

All the alternators ever designed failed to give isochronous impulses, but the alternators of high frequency which were designed in later years by my followers were very much

worse in this respect than mine for the simple reason that they were built for much higher frequencies -- the higher the frequency, the greater are the departures from isochronism. You see, certain definite fluctuations of speed will have a greater effect on the isochronous character of the oscillations if the periods are shorter; therefore, the higher the frequency of the dynamo the less isochronism there is. The dynamo of Alexanderson, designed for 200,000 cycles, cannot fail to show a very strong departure from isochronism -- much greater than in my dynamos of 1891 and 1892.

Counsel

Would your answers be the same if the source of current were a high frequency alternator or dynamo?

Tesla

If the source of current is an alternator of very high frequency, then the drawback comes in; that is, a wasteful action is introduced. Therefore, as I have stated, unless this dynamo is of reasonably low frequency, the effects will be undoubtedly modified, and would be not so good as when the frequencies which I have specified are employed.

Counsel

But, so far as concerns the principle involved, and the instrumentality employed, is there any real difference?

Tesla

Absolutely no difference.

Counsel

And that would be true even though you used some form of a transformer between the dynamo and the antenna?

Tesla

Exactly true.

Counsel

Referring to the different instrumentalities described as being used by you for supplying sustained electrical oscillations to an antenna of high capacity and tuned to the frequency of the current impressed, for the transmission of energy without wires, what, if any, difference in principle was involved in the transmitting of such energy to a distant telephone, for instance, or for signaling, as compared with

such transmission to any other form of translating device, such for instance, as a lamp?

Tesla

There is no difference whatever that I can see in the principle.

Counsel

Was there any difference in the equipment employed for these two purposes?

Tesla

Absolutely none that I can see.

Counsel

Would there be any difference in the principle or in the instrumentalities used if such work is carried on with a single-wire circuit?

Tesla

Not to my knowledge.

Counsel

Can you give some idea about the amount of expenditure involved in these various tests and experiments that you have described?

Tesla

Oh, the mere thought of those expenditures makes me ill. Why, I have expended in the wireless work, before I ever saw Colorado -- I think my secretary knows that -- I have expended certainly not less than \$750,000. And then I have spent in Colorado over \$60,000; yes, more than that -- \$70,000; and I have spent about \$500,000 on the Long Island plant. If my results had been proportionate to those expenditures, I would be a great man today in Wall Street.

Counsel

What was the distance of the receiver from the sending station in the Colorado test?

Tesla

Well, these distances were small, for the reason that they were merely intended to give me quantitative data.

Counsel

Could you give the number of miles, approximately?

Tesla

Oh, 10 miles or so.

Counsel

And what form of receiver did you use in this instance?

Tesla

All kinds of forms. Some of them have been described and published; others I have not yet published, and the finest ones of them are not published yet.

Counsel

In the Long Island test, what was the greatest distance that you transmitted there?

Tesla

Similarly, in the Long Island plant, I was too much absorbed in the construction and the plant was not yet quite ready. The experiments which I made there were simply preparatory.

Counsel

Was the receiver substantially the same as that used in Colorado?

Tesla

Yes -- substantially the same.

Counsel

And when you came to this greater distance of 30 miles to West Point, what kind of a receiver did you use in that instance?

Tesla

I used several receivers. I made several trips to West Point. In one of these experiments I used what I have termed a small mass resistance, something on the principle of the Bolometer. The received oscillations passed through a conductor of extremely small mass, which I have managed to produce, and thereby the heating produced differences of potential

which could then be detected in the telephone through the use of a battery.

Counsel

Could you tell, just in a few words, the mechanism actually used by you in Colorado for getting the continuous waves?

Tesla

I produced these continuous waves in several ways; but before I answer that question, let me define what a continuous or undamped wave means. That is so elastic a term, and there is such confusion in this respect, that unless I elucidate that a part of my remarks will not be understood.

I have pointed to this already, and I have given a mechanical analogue by a bell. If you put a bell in mercury -- a dense, heavy medium, and you attempt to make this bell vibrate, you will find that, unless the blows of the hammer with which you try to keep the bell swinging are delivered in a very rapid succession, the vibrations of the bell will die out between the successive blows. But, if you take a bell and put it in a vacuum, with no resistance, with nothing to take up energy, then you can tap the bell once in every half hour and still it will ring with practically the same note, the same intensity. Therefore, before we talk of these continuous or undamped waves, we must realize what conditions there existed to keep up waves of this character. It makes a vast difference. In one apparatus the waves will die out quickly; in another one, they will not. Even when I operated as in some instances with a few of these hammer blows, even then, owing to the design of my circuit, the waves were practically continuous; but I have had several ways of obtaining absolutely undamped waves, irrespective of the manner in which the energy was taken out from them.

Counsel

That is, at the Colorado station, you mean?

Tesla

Yes. One of these devices comprised two choking coils, which I connected to the mains of a 550-volt circuit. These choking coils were connected to a condenser, and in series with this condenser was a primary. I would establish across that a spark gap or arc, and directly I did this a continuous oscillation of any period what I desired was produced, and I would adjust it by altering the capacity of my condenser or by varying the turns of that self-inductance coil which you have

seen there [i.e., self-inductance coil with wooden crank handle shown in Fig. 57], which I usually used in these experiments. That method was described by me long ago. It was described in my patents and practiced by many electricians. There was nothing novel in it, except that in 1896 I introduced these coils for raising the tension from 550 volts to a much higher voltage so that I could employ [a] smaller condenser and [obtain] a more vigorous vibration. That was a well known way.

Counsel

What was the effect on the frequency of this raising of the voltage at the same time?

Tesla

Well, the frequency remained any frequency I wanted. There was no effect on the frequency, except that the energy of the oscillation was greater and the frequency could be pushed higher if I wanted it.

Besides this, I had another way of producing continuous oscillations. That was by driving a mechanically operated break, such as I have shown. This I would rotate at a certain speed, having such a number of breaks as corresponded to the number of half-waves of the oscillating antenna circuit, which of course was coupled to the primary.

To show you how I did this, I operated, for instance in Colorado, with frequencies from 5,000 -- in fact, lower than 5,000, up to any frequency, say 100,000. Suppose I had 5,000 oscillations per second in the antenna, and I rotated my break in such a way that it gave me 10,000 makes and breaks; then my make-and-break was in synchronism with the waves in the antenna and I produced a train of perfectly undamped waves.

Furthermore, I have also operated with an ordinary break, as I showed in one of those earlier [figures], and I have relied on the great energy accumulated in the antenna to bridge over the gaps of the successive discharges. I have had my circuit so constructed that even if I used only the frequency of the ordinary dynamo, say 300 interruptions per second, I still could bridge over the gap between these interruptions with the waves in the antenna.

Counsel

And this apparatus that you have been just describing is what you actually used at Colorado?

Tesla

I actually used in all these three forms, almost every day, all these devices; and furthermore, I had other methods which are not yet patented, and those are corking fine methods.

Counsel

That was, as I understood, spark gap transmission?

Tesla

It was impossible to produce this tremendous energy which I needed in my experiments with the high frequency machine. That is the reason why I relied on that method, because with that method I could get any energy I wanted from the circuit. With the high frequency alternator, I could not. The waves are absolutely identical; you can produce them either one way or the other. They are of the same character -- sinusoidal.

Counsel

Do you use "spark" and "arc" as simply equivalent terms, or whether they mean anything especially different?

Tesla

Yes, they are equivalent. I never make any distinction between them. If the spark stream is continuous and fat, it is nothing but an arc. I never have approved of this distinction between an arc and a spark; there is no distinction.

Counsel

The question is, whether the waves are damped or not. Perhaps in this case the adjustments were such that they were undamped -- is that it?

Tesla

As I say, with the transmitters I have designed, and the way they operate, you cannot get anything but undamped waves, unless you want. In those striking effects which I produced for a certain purpose, I did use damped waves in order to magnify my effects.

Counsel

Earlier [p. 85], you referred to certain experiments that had been made by Mr. Pickard and which you criticized as having been improperly made. Do you know in what connection Mr. Pickard made those experiments?

Tesla

I understood from Mr. Pickard that in a certain suit, of which I do really know nothing, the question came up as to whether the apparatus described in my patents, which have been frequently quoted, of March and May, 1900 [referring to U.S. Patent Nos. 645,576 and 649,621] -- whether an apparatus constructed exactly as described in those patents would be capable of transmitting commercial messages, and Mr. Pickard told me that he made up exactly the same transmitter, true to dimensions, and that they transmitted messages 200 or 300 miles with the greatest facility.

On that occasion he told me he had employed a certain antenna. Then I called his attention to the fact that if he had calculated the antenna so as to adapt it to an oscillating circuit of greater energy, he could have transmitted the message to any distance he liked, perhaps across the Atlantic, but Pickard did not do that. He just used a primary condenser capacity of 0.04 microfarad I believe as I described [in] that patent, instead of putting up a big capacity there, developing more energy in the oscillator, slowing down the oscillations and employing a more efficient system of greater energy. He could have then transmitted messages to great distances without the slightest difficulty. He said that he knew it, but that there was no purpose in transmitting to great distance, that the object was simply to show that the apparatus was designed on rational lines.

I would like to correct an erroneous impression. I did not mean to criticize the work of Mr. Pickard. I simply say that he could have performed an experiment under those conditions.

Counsel

Quite outside of the question of the difficulties that you had, from a commercial point of view in financing some of these ideas that you agreed with and still agree with, were any of the various patents that you have referred to having to do with the transmitting end used commercially; that is to say, installed either in connection with some system that took messages for pay or in connection with the Navy, or some other either private or public body?

Tesla

Yes -- the owners of my patent in the first place gave a license to an engineer who was making installments for the Navy; and, as a matter of fact, on the biggest vessels of the Navy the system was installed under my patents -- my transmitter, my receiver, with four tuned circuits.

Counsel

Who was that?

Tesla

This was Mr. Fritz Lowenstein, who began the introduction about five years ago, supplying to the Navy, continuously, from my patents. Yes, he started about five years ago, and since that time he has been continuously introducing it. As a matter of fact, the naval officials have acknowledged that it was the best apparatus on the market.

Counsel

What do you mean by apparatus? Will you give me a definite reference?

Tesla

I mean the transmitter and receiver described in my fundamental patents of March and May, 1900, which have frequently been referred to; patents relating to various ways of producing oscillations of which there are a number. The owners of the patents gave a license to Lowenstein, under eight or nine patents, which have been displayed on the nameplates.

Counsel

These matters are presumably public, involving an expenditure by the Navy of approximately how many dollars?

Tesla

I know they spent probably \$40,000 or \$50,000.

Counsel

My question is not confined to the Navy. I am seeking to ascertain what commercial use, if any, your patents have been put to. We have already established what is understood as commercial use, which would include Tuckerton, Sayville, the Navy -- any place where the patents are being actually used, or have been used for something more than experimental purposes, and for something more than to merely satisfy either yourself or others as to their practicability; or, in other words, where the patents have been used under circumstances where real money has been paid for the use of the patents. Have not the Goldschmidt people at the Tuckerton station [*],

* Editorial note: For an interesting dissertation on this topic, see Nunn, Roy M., The Goldschmidt Wireless of Tuckerton, New Jersey, submitted to the History Department of Albright College, May 1967, in partial fulfillment of the requirements for BA degree (46 pp.).

as well as the Telefunken people at the Sayville station, for some years been operating as a licensee under the Tesla principal patents?

Tesla

Yes.

Counsel

During what years was Mr. Fritz Lowenstein connected with you or your company?

Tesla

Mr. Fritz Lowenstein came to me in 1899, recommended by the private consular of Germany, and he stayed with me about three weeks while I was at 46 East Houston Street. When I needed an assistant in Colorado, he came for a short while to Colorado Springs and left me again in early or about the middle of September, 1899, before my plant was really completed. Then again, while I was carrying on the first construction on Long Island, during the first process of construction, while the plant [was] not yet far advanced, he was there again for a certain period. He was always with me for a short period, and was not employed by my company in any way. It was a matter of having an expert for a short time until he would get employment somewhere else.

Counsel

When did he last work for you?

Tesla

He did not work for me since 1902.

Counsel

Thank you, Mr. Tesla, for your presentation which took the form of a lecture occupying some days. I think we were all deeply interested, as an intellectual exercise, and attracted by the unusual character of the subject.

- END -

Appendix I

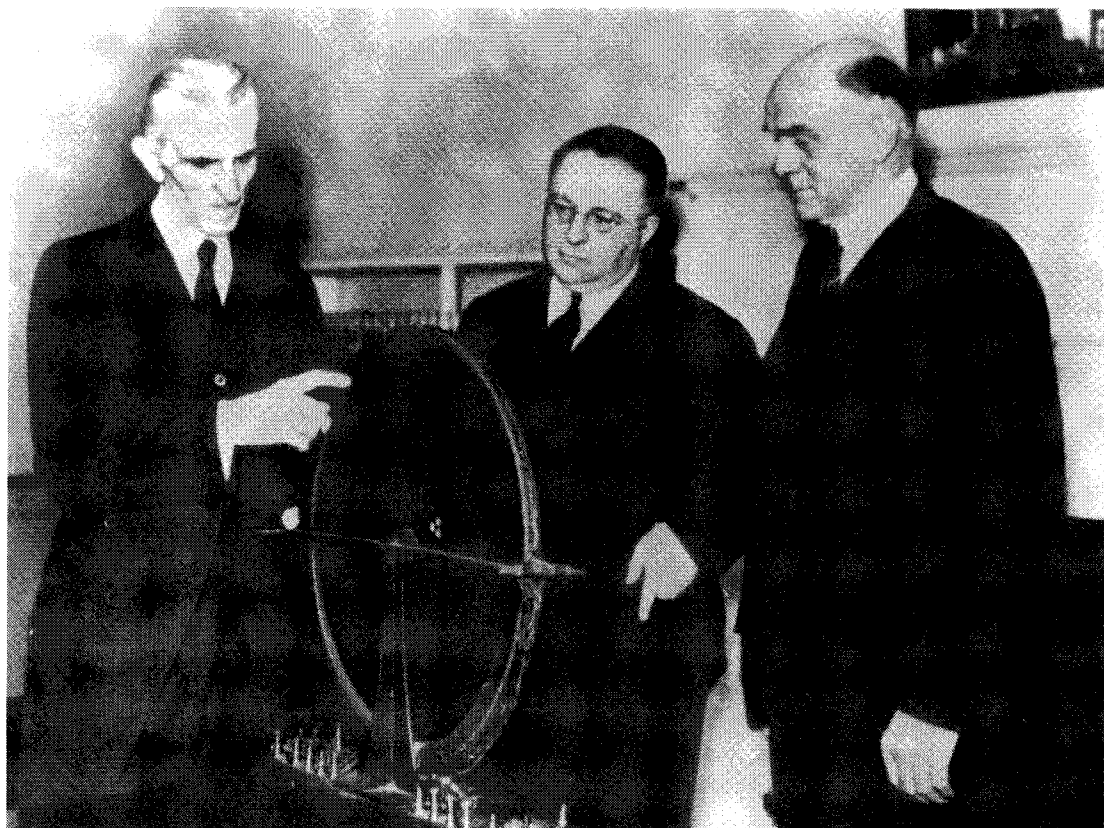

Westinghouse

Figure A1-1 (reference from p. 17).

In the spring of 1938, the Societe pour la Foundation le l'Institute Nikola Tesla of Belgrade, Yugoslavia, communicated with the Westinghouse Electric & Manufacturing Company concerning its endeavor to collect information about Tesla's early work. Victor S. Beam, patent counsel for the Westinghouse Company, had earlier uncovered an alternator in company storage identified as belonging to Tesla, and an invitation was extended to Tesla to be photographed with the alternator in Mr. Beam's office, 150 Broadway, New York City. An appointment was scheduled for May 10, 1938. When Tesla arrived, he recognized the alternator as one that had escaped destruction in his laboratory fire March 13, 1895. The Westinghouse Company had borrowed the alternator, but the fire disaster so absorbed Tesla's efforts in re-establishing his laboratory that the machine was forgotten.

Five photographs were taken on the occasion of Tesla's visit. In this photograph are shown, from the left, Tesla, Victor Beam, and John T. Morris, Secretary to Mr. Beam.

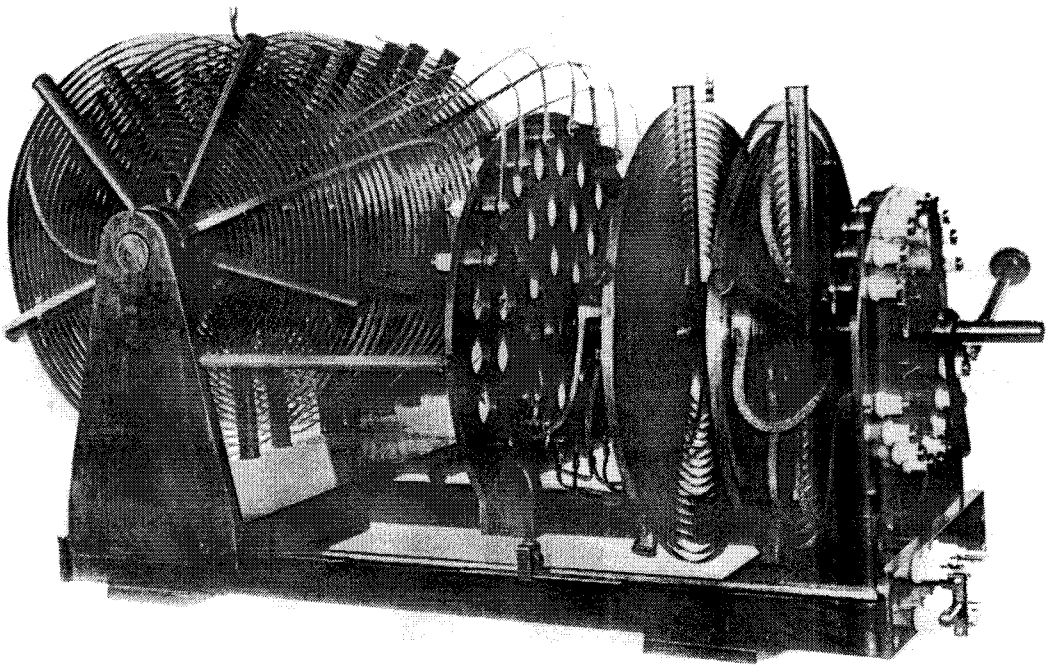

George Scherff

Figure A1-2 (reference from p. 85).
Shipboard quenched-spark transmitter, produced by the Lowenstein Radio Company and licensed under Nikola Tesla Company patents, installed on naval vessels prior to WWI. Shown is a 5-kilowatt transmitter having a range up to 1,500 miles. Note that this apparatus adopts the flat-spiral type of antenna-circuit coils shown in the Tesla sister patents No. 645,576 and 649,621 of May 1900. Secretary of Navy Josephus Daniels remarked that this apparatus was "superior to any other" at that time.

Appendix II

Wardenclyffe Foreclosure Appeal Proceedings

In the spring of 1899, before establishing his experimental station at Colorado Springs, Tesla took up residence at the old Waldorf-Astoria, a rococo style, red-stone hotel located at Fifth Avenue between 33rd and 34th streets, now the site of the Empire State Building. When the Wardenclyffe project ran into financial difficulties, Tesla mortgaged the property in 1904 to George C. Bold of the Waldorf-Astoria for expenses of residence and entertainment furnished him. In 1908, Tesla again mortgaged the property to the Waldorf-Astoria for the same necessity.

The anticipated income of the Wardenclyffe project from transmission of messages across the Atlantic was unrealized; Tesla was unable to repay the mortgages. Action was taken by the mortgagees in 1915 to foreclose the property, and a bill of sale offered to Lester S. Holmes. The tower was destroyed in order that the property could be commercially developed. Tesla appealed the foreclosure judgment, and the case was heard by the Supreme Court of the State of New York, Suffolk County. Tesla lost the case on appeal. Following the judgment on April 20, 1922, Tesla vacated his suite at the Waldorf-Astoria and took up residence at the Hotel St. Regis.

The transcript of the case substantially revolves on matters concerning the merit of the legal instruments involved in the mortgaging and foreclosure actions. However, in the course of the testimony given by Tesla, important information about the Wardenclyffe installation is provided. A portion of the testimony by Ezra C. Bingham, chief engineer for the Waldorf-Astoria, is also of interest with respect to the condition of the premises and its vandalization. In addition, a complete inventory of the plant is given as Exhibit B. These extracts from the transcript of the case are reproduced in the pages that follow.

The pagination of the original transcript appears top center of each reproduced page. The pagination of this work is shifted to bottom center on the numbered pages of the transcript. The extracted transcript sections are:

| | transcript pages |
|--|------------------|
| Nikola Tesla for Defendant-Direct | 163-181 |
| Ezra C. Bingham for Plaintiff-Direct | 235-247 |
| Nikola Tesla for Defendant-Direct | 269-275 |
| Defendants' Exhibit B [inventory of plant) | 309-312 |

Supreme Court,

APPELLATE DIVISION—SECOND DEPARTMENT.

CLOVER BOLDT MILES AND GEORGE C. BOLDT, JR., AS EXECUTORS OF THE LAST WILL AND TESTAMENT OF GEORGE C. BOLDT, DECEASED,

Plaintiffs-Respondents,

against

NIKOLA TESLA,

Defendant-Appellant,

THOMAS G. SHEARMAN,

Defendant-Respondent,

et al.,

Case on Appeal.

WILLIAM RAJESWARI, JR.,

Attorney for Defendant-Appellant,

305 Broadway,

New York City.

BALDWIN & HUTCHINS,

Attorneys for Plaintiffs-Respondents.

WILLARD A. MITCHELL,

Attorney for Defendant-Respondent, THOMAS

G. SHEARMAN.

A. Of course I had signed and the transaction was completed. 487

Q. And those papers were then in Mr. Hutchins' possession?

A. Yes those were almost his parting words.

Q. I think you said that conversation took place early in 1917 or late in 1916?

A. I think early in 1917, if I remember rightly, but my memory is a little—on account of the concentration—

Mr. Hawkins: I do not recall the date of that deed.

Mr. Fordham: Why don't you let your witness complete his answer about his memory? 488

Mr. Hawkins: I assumed he had.

By Mr. Fordham:

Q. What were you saying?

A. I answered all the questions to the best of my ability.

Q. No, counsel interrupted you intentionally in the middle of a sentence—

Mr. Hawkins: That is not true, that I interrupted him intentionally.

Mr. Fordham: Well, strike out the word intentionally. You interrupted him in the middle of the sentence. He can say what he started to say about his memory in connection with this transaction. The witness evidently thinks he does not need to pay any attention to what I say. Will your Honor kindly instruct the witness to complete his answer. 489

By the Referee:

Q. Had you completed your answer?

A. Yes, those were the parting words of Mr. Hutchins.

490 By Mr. Hawkins:

Q. As Mr. Fordham seems anxious to have you complete what you said, I heard what you said——

Mr. Fordham: He says he has completed.

A. Yes, in regard to the memory of the exact date, I say that I cannot exactly remember the dates on account of concentration on some other work that I am doing now, but I can easily ascertain all the dates from documents.

491 Q. Now at the time that you delivered that document to Mr. Hutchins, I refer now to the deed, will you please describe to the Court what there was upon the property?

A. Upon the property?

Q. Yes, described in the deed, which property is situated at Rocky Point.

Mr. Fordham: That is objected to on the ground it is incompetent, immaterial and irrelevant at this point what there was on the property.

The Referee: I will take it.

Mr. Fordham: We except.

The Referee: You mean structures, I suppose?

492 Mr. Hawkins: Yes, absolutely. Improvements, I had in mind, if there were any buildings there or structures.

Q. Tell the Court what there was there.

A. There was a brick building in which was located the power plant——

Q. Please describe the size of the brick building.

A. The building forms a square about one hundred by one hundred feet wide and it is one floor, rather high, with a roof covered with gravel, as they usually make them. This building was divided in-

side in four compartments, two of which were very large, one being the machine shop— 493

Q. How large was that?

A. That was one hundred feet by about thirty-five feet, I should say.

Q. Now tell how big the other compartments were.

A. The other one was about one hundred by thirty-five and then these other two smaller ones where the engines were located on one side and the boilers on the other were about thirty by forty, thirty one way and forty the other.

Q. I think you said the building was one story high? 494

A. Yes.

Q. It had one floor, did it?

A. One floor, yes.

Q. Further describe the building, if there is any further description, and tell the Court whether there were any brick chimneys, outside chimneys?

A. Oh yes, right in the center of the building rose the chimney.

Q. How big was the chimney?

A. The chimney was four by four feet; it was calculated to give the proper speed to the products of combustion under the boilers. 495

Q. Of what was the chimney composed?

A. Brick.

Q. How high was the building?

A. The building might have been, I think the extent of the walls on one side, the lowest part of the roof might have been something like twenty-eight feet, I would say.

Q. Twenty-eight feet at the corners of the building?

A. Yes.

496 Q. And did it have a gable roof or a lantern roof?

A. Yes, as you call it in English—how is this roof called?

Q. I think it is a gable roof.

A. Gable roof. The building was resting on cement foundations and there were the usual modern conveniences and——

Q. Tell what you mean by the usual modern conveniences?

497 A. I mean the channels for leading off the waste, the rain drips and all that, and then attached to it was, of course, the water pump that pumped the water for the building.

Mr. Fordham: I do not wish to interrupt counsel but what possible use can there be in a detailed description of the building on this property?

The Referee: I do not know at this time.

Mr. Fordham: Neither do I. It does not seem to me that we should burden the record indefinitely with these descriptive details.

The Referee: I will let him describe them.

498 Mr. Hawkins: It is a material part of the defense here.

The Referee: Go ahead. I will take it.

The Witness: I suppose what belongs to the buildings is the boiler plant, with two 300-horse power boilers on one side——

Q. That was two 300-horse power?

A. Two 300-horse power boilers, yes, and the pumps, injectors and other accessories, and then there were big water tanks that were placed around the chimney so as to utilize some of the waste heat. These tanks had a capacity of about 16,000 gallons, if I am correct.

Q. Of what were the tanks composed?

499

A. Of quarter inch thick sheet steel, galvanized.

Q. Those were all in one compartment, were they?

A. They were around the chimney under the roof, and for this purpose the room had an extension upward there. This could be shown on a photograph if his Honor wishes to see the photograph.

Q. Just a moment please. Now describe the other three compartments of the building.

A. Well, I have described the boiler plant. Now right opposite to the boiler plant lengthwise was a corresponding compartment and therein were located the engines. Of these engines there was one 400-horse power Westinghouse reciprocating engine, driving a directly connected dynamo which was specially made for my purposes. Then there was a 35-kilowatt Westinghouse outfit also driving the dynamo, which was for the purpose of lighting and other work, a permanent attachment to the building to furnish all conveniences. There was then a high pressure compressor which also formed an essential part of the equipment. And then there was a low pressure compressor or blower. Then there was a high pressure pump and a reciprocating low pressure pump. That was all—

500

501

Q. Water pumps?

A. Water pumps, yes. Those were all in that compartment, and of course this compartment also contained the switches and the switchboard and all that which goes with the equipment of the plant. Then there was a gallery on the top on which certain parts were placed and arranged that were needed daily in the operation.

Q. Those were parts of what?

A. Well they were the tools, you know, that were needed in the plant.

502 Q. Please describe another compartment.

A. The compartment that was towards the railroad, that was the machine shop.

Q. Which part of the building was that, the north, south, east or west?

A. I cannot locate it—

The Referee: The north side.

The Witness: Towards the road, facing the road. That compartment was one hundred by thirty-five feet with a door in the middle and it contained I think eight lathes.

503 The Referee: You are speaking now, when you said facing the road, that is on the south side, the travel road or—

The Witness: Facing the railroad. It is just close on the railroad track, your Honor, this building. That contained I think eight lathes ranging in swing from eight inches to thirty-two, I believe. Then there was a milling machine and there was a planer, and shaper, a spliner, a vertical machine for splining. Then there were three drills, one very large, another medium and a third quite small one. Then there were four motors which operated the machinery. Also a grinder and an ordinary grindstone, a forge—

504

Q. Blacksmith's forge?

A. Yes, a blacksmith's forge. Then a special high temperature stove and the blower for the forge. Of course the shop was full of counter shafting and there were a few special tools which suited certain purposes which I contemplated there. I cannot at present recall them exactly, but there were five or six of them.

Q. Were those stationary tools or hand tools?

A. No, some of them were attachments to the

ordinary lathes or milling machines, suitable for 505
certain work and others were of course portable.

Q. Now have you described the four compartments of the building?

A. No. Now the compartment opposite, that is facing further away from the railroad, which also was one hundred feet, the whole length of the building, by about thirty-five, there is where the real expensive apparatus was located. That contained also the desks and the office accessories. Shall I describe now this one?

Q. Yes, describe any stationary fixtures there were in this other compartment.

A. Well, is machinery a stationary fixture? 506

Q. Yes we call that a stationary fixture.

A. Right along the back wall that separated this compartment from the rest of the building there were two special glass cases in which I kept the historical apparatus which was exhibited and described in my lectures and scientific articles. There were probably at least a thousand bulbs and tubes each of which represented a certain phase of scientific development. Then close, beginning with these two glass cases, there were five large tanks. Four of those contained special transformers according to my design, made by the Westinghouse Electric 507
Manufacturing Company. These were to transform the energy for the plant. They were about, I should say, seven feet high and about five by five feet each, and were filled with special oil which we call transformer oil, to stand an electric tension of 60,000 volts. Then besides these four tanks there was another similar tank which was for special purposes, containing a transformer. Then there were two doors, one door that led to the other compartment and the other one led in the closets, and between those two doors there was a space on which

508 was placed my electric generating apparatus. This apparatus I used in my laboratory demonstrations in two laboratories before, and I had also used it in the Colorado experiments where I erected a wireless plant in 1889. That apparatus was precious because it could flash a message across the Atlantic, and yet it was built in 1894 or 1895. That is a complicated and very expensive apparatus.

509 Then beyond the door there were again four tanks, big tanks almost the same size as those I described. These four tanks were to contain the condensers, what we call electric condensers, which store the energy and then discharge and make it go around the world. These condensers, some of them, were in an advanced state of construction, two, I think, and the others were not. They were according to a principle of discovery. Then there was a very expensive piece of apparatus that the Westinghouse Company furnished me; only two of this kind of apparatus were made by the Westinghouse Company, one for me and one for themselves. It was developed together by myself and their engineers. That was a steel tank which contained a very elaborate assemblage of coils, an elaborate regulating apparatus, and it was intended to give
510 every imaginable regulation that I wanted in my measurements and control of energy. Then on the last side, where I had described the first four big tanks there was a special 100-horse power motor and this motor was equipped with elaborate devices for rectifying the alternating currents and then sending them into the condensers. On this apparatus alone I spent thousands of dollars. The 100-horse power motor was specially constructed for me by the Westinghouse Company, but the other parts were all made by myself and that took a considerable portion of space there and it was a

wonderful piece of apparatus. I have photographs 511
of these which will make this description very clear.

Then along the center of the room, I had a very
precious piece of apparatus. That was a boat which
was illustrative of my discovery of teletaumatics;
that is a boat which was controlled without wire,
which would do anything you wanted, but there
was no connection. This boat was exhibited by me
on many occasions.

Q. The boat was not stationary, was it?

A. It was stationary, yes, on the supports. It
was stationary on the supports but as I say that
boat was my wireless boat; that is a boat that you 512
commanded it and it would perform as many evolu-
tions as you wanted, by just commanding it.

Q. Was that about all there was, generally speak-
ing?

A. Oh, no, nowhere near. Then there were
on each side long specially made, how do you call
them, not desks or shelves, but closets, I might say,
which were specially made to contain the apparatus,
because I had accumulated for years hundreds of
different kinds of appliances which stand for a cer-
tain principle, and this apparatus was stored in
there, and on top of these I had again all full of 513
apparatus, each representing a different phase.
And then on one side there were the desks and then
on the other side there were the drawing imple-
ments and tools. And then in the corner, when you
looked at the railroad side, on the right side in the
corner there was my testing room and that con-
tained—there were two precious instruments
among these that Lord Kelvin made especially for
me. He was a great friend of mine. A device for
measurement invented by him; it is called a breach;
and another a voltmeter of his. Both of these
things were given to me and prepared for me by his

514 special instructions. There were a lot of other instruments, voltmeters, wattmeters, ampere meters; in that small space there was a fortune in there.

Mr. Fordham: The last, that there was a fortune in there, calls for a conclusion as to the salable value of the stuff and I think it should go out.

The Referee: Yes, strike it out.

Q. I think you said this building was constructed of brick, did you not?

A. Yes.

Q. How thick were the walls of it?

515 A. That I cannot tell now exactly, but I should say about twelve inches.

Q. It was more than one brick thick, at any rate?

A. Oh, I should say so. I paid something—

Q. I presume this building had windows in it?

A. Oh yes there were large windows which were divided into panels.

Q. And what were the window sash made of, metal or wood?

A. Wood sashes.

Q. I show you a document, Defendant's Exhibit C, and call your attention to the signature on that
516 document, and ask you if that is your signature?

A. Yes sir, that is my signature.

Q. Do you recognize the instrument?

A. Yes sir, that was one of the—

Q. That is the deed which you delivered, is it not?

A. Yes.

Q. I call your attention to the date of the deed, March 30, 1915.

A. 1915?

Q. Yes.

A. Well that was—1915?

517

Q. Yes.

A. I was under the impression it was a little later.

Q. Well that is the only deed which you delivered in the transaction to Mr. Holmes, is it not?

A. Hutchins?

Q. Hutchins, yes.

A. So far as I know.

Q. Then would you like to change your testimony when you said it was in 1917? The date of this in March 30, 1915.

A. I have stated that I was not sure about the dates, but I could ascertain it exactly by looking at the documents. 518

Q. Well there is the document.

A. Well it must be so because it is there.

Q. It is 1915 then instead of 1917?

A. Yes, but my impression was that this was another attorney who had it first and it was made to Mr. Hutchins later.

Q. I do not know what you mean by saying it was made to Mr. Hutchins. The grantee in the deed is Lester S. Holmes.

A. Yes, Lester S. Holmes.

519

By the Referee:

Q. The transaction you had was with Mr. Hutchins?

A. Yes that is all.

The Referee: I do not think there is any dispute about that.

Mr. Fordham: There was only one, I understand. The witness does not claim there were two, one in 1915 and another in 1917.

The Witness: No.

520 By Mr. Hawkins:

Q. No there was only one and Mr. Holmes was the grantee in the deed which you gave to Mr. Hutchins, was he not?

A. Yes, and I recall the transaction with Mr. Hutchins.

Q. Were there any other structures upon the property aside from the building?

By the Referee:

Q. Did you read that paper at the time you executed it?

521 A. Yes at the request of Mr. Hutchins.

By Mr. Hawkins:

Q. Were there any other structures upon the premises other than that brick factory or laboratory which you have just described?

A. Yes sir, there was the structure which in a certain sense was the most important structure, because the power plant was only an accessory to it. That was the tower.

522 Q. Please describe the tower as to dimensions and material and method of construction and kind of construction?

Mr. Fordham: We renew our objection, if the Court please. This is entirely immaterial, irrelevant and incompetent until after they have succeeded in establishing their contention that the deed is a mortgage.

The Referee: I will take it.

Mr. Fordham: Exception.

A. The tower was 187 feet high from the base to the top. It was built of special timber and it was built in such a way that every stick could be

taken out at any time and replaced if it was necessary. The design of the tower was a matter of considerable difficulty. It was made in the shape of an octagon and pyramidal form for strength and was supporting what I have termed in my scientific articles a terminal. 523

By the Referee:

Q. There was sort of a globe at the top?

A. Yes. That, your Honor, was only the carrying out of a discovery I made that any amount of electricity within reason could be stored provided you make it of a certain shape. Electricians even today do not appreciate that yet. But that construction enabled me to produce with this small plant many times the effect that could be produced by an ordinary plant of a hundred times the size. And this globe, the framework, was all specially shaped, that is the girders had to be bent in shape and it weighed about fifty-five tons. 524

By Mr. Hawkins:

Q. Of what was it constructed?

A. Of steel, all the girders being specially bent into shape.

Q. Was the tower that supported it entirely constructed of wood or partly steel? 525

A. That part alone on top was of steel. The tower was all timbers and of course the timbers were held together by specially shaped steel plates.

The Referee: Braces?

The Witness: Yes, steel plates. I had to construct it this way for technical reasons.

The Referee: We are not interested in that.

Q. Was the tower enclosed or open?

A. The tower, at the time of the execution of this

526 deed, was open, but I have photographs to show how it looked exactly and how it would have looked finished.

Q. After you delivered the deed was the tower ever enclosed?

A. No, it was just open.

Q. Now the dome or the terminal at the top, was that enclosed?

A. No sir.

Q. Never enclosed?

A. Never enclosed, no.

Q. Had that structure ever been completed?

527 A. The structure so far, if I understand the terms right, yes, the structure was all completed but the accessories were not placed on it yet. For instance that globe there was to be covered with specially pressed plates. These plates——

Q. That had not been done, had it?

A. That had not been done, although I had it all prepared. I had prepared everything, I had designed and prepared everything, but it was not done.

Q. Was the structure of the tower in any manner connected with the brick building or power plant?

A. The tower was separate.

528 Q. I understand, but was there any connection between them?

A. There were of course two channels. One was for communicating, for bringing into the tower compressed air and water and such things as I might have needed for operations, and the other one was to bring in the electric mains.

By the Referee:

Q. In order to do that there was, as a matter of fact, was there not, a well-like shaft going down right in the middle of the tower into the ground some fifty or sixty feet?

A. Yes. You see the underground work is one of the most expensive parts of the tower. In this system that I have invented it is necessary for the machine to get a grip of the earth, otherwise it cannot shake the earth. It has to have a grip on the earth so that the whole of this globe can quiver, and to do that it is necessary to carry out a very expensive construction. I had in fact invented special machines. But I want to say this underground work belongs to the tower. 529

By Mr. Hawkins:

Q. Anything that was there, tell us about. 530

A. There was, as your Honor states, a big shaft about ten by twelve feet goes down about one hundred and twenty feet and this was first covered with timber and the inside with steel and in the center of this there was a winding stairs going down and in the center of the stairs there was a big shaft again through which the current was to pass, and this shaft was so figured in order to tell exactly where the nodal point is, so that I could calculate every point of distance. For instance I could calculate exactly the size of the earth or the diameter of the earth and measure it exactly within four feet with that machine.

Q. And that was a necessary appurtenance to your tower? 531

A. Absolutely necessary. And then the real expensive work was to connect that central part with the earth, and there I had special machines rigged up which would push the iron pipes, one length after another, and I pushed these iron pipes, I think sixteen of them, three hundred feet, and then the current through these pipes takes hold of the earth. Now that was a very expensive part of the work, but it does not show on the tower, but it belongs to the tower.

532 By Mr. Fordham :

Q. Was the hole really one hundred and twenty feet deep, did you say?

A. Yes, you see the ground water on that place is about one hundred and twenty feet. We are above the ground water about one hundred and twenty feet. In the well we struck water at about eighty feet.

By the Referee :

Q. What you call the main water table?

533 A. Yes the main well we struck at eighty feet, but there we had to go deeper.

By Mr. Hawkins :

Q. Tell the Court generally, not in detail, the purpose of that tower and the equipment which you have described connected with it?

Mr. Fordham : How is that material?

The Referee : I will take it.

Mr. Fordham : We except.

534 A. Well, the primary purpose of the tower, your Honor, was to telephone, to send the human voice and likeness around the globe.

By the Referee :

Q. Through the instrumentality of the earth.

A. Through the instrumentality of the earth. That was my discovery that I announced in 1893, and now all the wireless plants are doing that. There is no other system being used. And the idea was to reproduce this apparatus and then connect it just with a central station and telephone office, so that you may pick up your telephone and if you wanted to talk to a telephone subscriber in Aus-

tralia you would simply call up that plant and the 535
plant would connect immediately with that sub-
scriber, no matter where in the world, and you
could talk to him. And I had contemplated to have
press messages, stock quotations, pictures for the
press and these reproductions of signatures, checks
and everything transmitted from there throughout
the world, but——

By Mr. Hawkins:

Q. The purpose then briefly was for wireless
communication to various parts of the world?

A. Yes and the tower was so designed that I 536
could apply to it any amount of power and I was
planning to give a demonstration in the transmis-
sion of power which I have so perfected that power
can be transmitted clear across the globe with a
loss of not more than five per cent, and that plant
was to serve as a practical demonstration. And
then I was going to interest people in a larger
project and the Niagara people had given me
10,000-horse power——

Q. What do you mean by power, energy?

A. Yes, power in any amount.

Q. Were there any other structures upon the 537
premises?

A. No, just these two big structures.

Q. I call your attention, Mr. Tesla, to Defendants
Exhibit A which I characterize as a bill of sale and
ask you to notice the signature there.

A. That is my signature, sir.

Q. Now the date of this document is the 30th day
of March, 1915?

A. Yes sir.

Q. Is that the bill of sale that was delivered the
same time the deed was delivered?

A. Yes.

538 Q. I do not wish to repeat this, but when you stated that that was also on or about the early part of 1917 you had in mind this document which you delivered in March, 1915?

A. Yes, but what stands out in my mind strongest is the construction of the tower, and that is the reason I have that in mind, the construction of the tower.

Q. Do you recall the testimony of Mr. Hutchins, that the Waldorf entered possession of the property?

A. Of Hutchins?

539 Q. Do you recall the testimony of Mr. Hutchins?

A. Yes, I recall something of that which he stated.

Q. And when was that done, in 1917, before or subsequent to the destruction of the tower?

A. It was done some time before the actual destruction of the tower.

Q. Do you recall when the tower was destroyed?

A. It was about in 1917, as near as I can recall, but I can ascertain——

Q. When was the tower erected?

A. The tower was erected from 1901 to 1902.

Q. What had you done to it to preserve it?

540 A. I spent considerable money on it by painting all the metal parts over three times, I think, each time at a cost of about a thousand dollars.

Q. Was there anything done to preserve the wooden portion of the structure?

A. Oh yes, we carefully watched everything, and——

Q. I know, but did you apply anything to it?

A. No not to the wood.

Q. Did not paint it?

A. No, not the wood.

Q. Had the wood been treated in any manner prior to being put in the construction, to preserve it? 541

Mr. Fordham: How is this material, your Honor? All this detail of preliminary work?

The Referee: I want to give counsel much latitude, but I suggest to be just as brief as you can about it.

Mr. Hawkins: Yes. My idea is this, if the wood had been creosoted or treated in any way to preserve it that was part of its value.

Mr. Fordham: Not unless it could have been sold for more money. It is absolutely immaterial. 542

The Referee: I will let him state if it had been treated.

A. No, but it was the finest timber.

Q. What was the timber?

A. Pine.

Q. What kind of pine?

A. I cannot tell you, there are so many kinds of pine in America.

The Referee: I think it was yellow pine.

The Witness: I could ascertain exactly.

The Referee: Timbers of that sort generally are. 543

Q. Now prior to the time when the tower was taken down did you have a conversation with Mr. Hutchins concerning that?

A. Concerning the tower?

Q. Concerning the destruction of the tower?

A. Concerning the destruction of the tower?

Q. Yes.

A. No, certainly not. He gave me a friendly assurance that nothing would be done in an unfriendly way.



Lillian McChesney

Figure A2-1
Construction detail of Wardencllyffe plant tower.

Note: This photograph was not an exhibit for the case.

The Referee: Overruled.

703

Mr. Hawkins: Exception.

Mr. Bingham: You may proceed, Mr. Bingham.

A. What is the question again, please?

The question was read as follows: Have you had any experience, and if so what, in the purchase and sale of machinery?

A. Well, I have not had any in a great many years—no, sir, either direct purchase or selling.

Q. Well, have you had any experience so that you are qualified to speak as to the value of machinery?

A. Only partially, I think.

704

Q. I call your attention to the testimony of the defendant Tesla, which appears on pages 88 to 161 of the record here inclusive, at the hearing on January 26, 1922, and ask you if you have read that testimony?

A. Yes, sir, I read that whole paragraph through.

Q. Are you acquainted with the premises referred to in the complaint in this action and the deed which is in evidence of the premises of the defendant Tesla?

Mr. Hawkins: That is objected to as immaterial, irrelevant and incompetent.

705

The Referee: Overruled.

Mr. Hawkins: Exception.

A. Yes, sir.

Q. When did you first visit those premises?

Mr. Hawkins: Same objection.

The Referee: Same ruling.

Mr. Hawkins: Exception.

A. Well, it is hard for me to state just when I first—

706 Q. (Interrupting.) Well, as near as you recall?

A. I would say about 1913.

Q. What was the occasion of your visit then?

Mr. Hawkins: Same objection.

The Referee: Same ruling.

Mr. Hawkins: Exception.

A. Mr. Boldt held a mortgage on this property and he sent me down there to check up and go over the condition of it and see what condition it was in.

Q. Yes; and how many times were you there?

Mr. Hawkins: Same objection.

The Referee: Same ruling.

707

Mr. Hawkins: Exception.

A. Oh, up until the time that I received that notice from Mr. Hutchins, I presume twenty times.

Q. The notice to which you refer is the letter of July 20, 1913, of which I show you a copy?

Mr. Hawkins: Same objection.

The Referee: Same ruling.

Mr. Hawkins: Exception.

A. Yes, sir.

Q. You haven't the original letter in your possession, have you?

708 A. No, sir; I have not.

Q. This is a correct copy?

A. Yes, sir.

The Referee: May I see that, Mr. Fordham? I do not just bear it in mind.

Mr. Fordham: Yes. I offer this letter in evidence.

Mr. Hawkins: Objected to as incompetent, irrelevant and immaterial and further on the ground that it is a self-serving declaration; and I further object to it because it is not the original document.

The Referee: I will take it.

709

Mr. Hawkins: Exception.

(Letter marked Plaintiffs' Exhibit No. 8.)

Q. Mr. Bingham, between the time you first went there to the property in 1913 and July 20, 1915, so far as you recall, how many visits did you make to the property?

Mr. Hawkins: Same objection.

The Referee: Same ruling.

Mr. Hawkins: Exception.

A. I could not say. I used to go there on an average of once or twice a month.

710

Q. During that period?

A. During that period.

Q. Will you please tell the Court what you found on the property during those visits?

Mr. Hawkins: Objected to as incompetent, immaterial and irrelevant and certainly can have no bearing upon the question as to whether these instruments were delivered as absolute conveyances or as security.

The Referee: Overruled.

Mr. Hawkins: Exception.

A. The first time I went down there I found the windows—well, I should say there was half a dozen of them that were wide open, and in the big room such as was used for experimenting and things of that kind there was probably a dozen or fifteen desks in there and a great many wardrobes, that is closets and things of that kind, and among them was a—what you would call a model submarine. Well, this place had practically been wrecked.

711

Mr. Hawkins: I ask that be stricken out.

The Referee: Yes, strike out the "practically been wrecked." Just describe its condition.

712 A. There had been a desk that the drawers had been opened, pulled out and thrown on the floor and all the tops of the desks—they were roll-tops desks—they had been ripped off and thrown on the floor, the doors were ripped off the closets and the books and stuff that was in there, I would say there was four truckloads of that thrown all over this big room, and I came back and made a report to Mr. Boldt of the condition we found things.

Mr. Hawkins: I ask that be stricken out.

The Referee: No, the fact that he made a report, let it stand.

713 Mr. Hawkins: Exception.

A. (Continuing.) And in two or three days I took a couple of carpenters and we went down there and nailed up the windows.

Mr. Hawkins: I ask that be stricken out.

Q. (Interrupting.) Well, Mr. Bingham, bear in mind the question I was asking you; the first time you went there in 1913 you did not go down and nail up windows, did you?

A. I did in two or three days.

Mr. Hawkins: Is the last part of that answer stricken out on my motion?

714 The Referee: Yes.

A. (Continuing.) And put in some light pieces of board, such as "Compo" board where the glass was gone out, so as to kind of protect the place, as at his suggestion he thought I better do that.

Mr. Hawkins: I ask that be stricken out.

The Referee: Strike out the last part.

Mr. Hawkins: And also that they nailed up boards.

The Referee: No, I will let that stand.

Mr. Hawkins: Exception.

Q. Proceed. What did you then discover? 715

A. About two weeks later I went down again and I found these things all ripped open again and the doors open, and I came back and locked them up the best I could and went over to see the station agent and they didn't know anything about what had happened or anything of that kind.

Mr. Hawkins: I ask that be stricken out.

The Referee: Granted.

A. (Continuing.) And in the meantime there had been some of these desks that was in there that was completely smashed up and taken away, I should say there was about half of them gone. 716

Mr. Hawkins: I ask that be stricken out.

The Referee: Denied.

Mr. Hawkins: Exception.

A. (Continuing.) And I went down, I would not say just how soon again, but probably within a month because I had to go there that often, Mr. Boldt insisted on my going down there and keeping a check on it.

Mr. Hawkins: I ask that be stricken out.

The Referee: Strike that out.

Q. You may say what you did? 717

A. I continually kept going down there up until the time I received this notice from Mr. Hutchins. Up until that time——

The Referee (interrupting): That is the exhibit that has just been offered.

Mr. Fordham: Yes, Exhibit 8, dated July 20, 1915.

Q. Proceed.

A. Up until that time they had practically stripped the place of everything; they had stolen off all the railings and everything that might per-

718 tain to brass of any description, even the boiler feed pumps they had taken the tops off and taken the valves and valve seats out; all the toilets, they had taken off the toilets and taken all the lead pipe back of the toilet and everything that could be possibly sold that could be drawn in any kind of a wagon had been taken away, I suppose for junk, that is the only thing they could possibly use it for.

Mr. Hawkins: I ask that be stricken out.

The Referee: The supposition strike out.

A. (Continuing.) The boilers were there, simply the headers and tubes; everything that pertained to
719 them were gone, they had stolen and dragged away; the dynamos were still there, the main part.

Mr. Hawkins: I ask the part of the answer in effect had been stolen be stricken out.

The Referee: Yes, the characterization stolen we will strike out. The fact that they were not there we will let stand.

Q. Proceed.

A. Well, that had been taken away.

The Referee: Well, they were gone?

The Witness: They were not taken for ornaments; they were gone.

720

The Referee: Yes.

The Witness: The engines, the main part of the engines were there, that is the foundation and the fly wheels, because they could not take them away; and some of the big part of the machinery, the different lathes and milling machines and the main drill-press; all small lathes and motors and everything of that kind were gone. What had become of them I could not say, but I would say they were stolen. And when I got this notice from Mr. Hutchins I

went down then and got the notice the same as 721
today, I made the signs up and went down to-
morrow and put up the signs, and in about a
week or ten days from then I took a couple of
trucks and went down there and brought the
big machinery away

Q Just what did you bring away?

A. I brought away a large drill-press, milling
machine, planer and two lathes.

Q. Do you know the value of those articles which
you brought away?

A. I do not know exactly the value of those
things. I have everything yet at the Waldorf, with 722
the exception of the milling machine.

Q. Well, was the value a few hundred dollars or
was it a great many thousand?

Mr. Hawkins: That is objected to on the
ground the witness is not qualified.

The Referee: Objection sustained.

Mr. Fordham: We except.

Q. You have the things now, with the exception
of the milling machine?

A. I have, with the exception of the milling
machine, yes, sir.

Q. Do you know what became of that? 723

Mr. Hawkins: That is objected to as imma-
terial.

The Referee: Overruled.

Mr. Hawkins: Exception.

A. That was sold; I don't know just now who
it was.

Q. You don't know?

A. No, but I could find out, I could look the book
up and find out who did buy it, but I don't re-
member.

724 Q. Do you know what was received for it?

A. No, I do not.

Q. I show you Defendants' Exhibit A, a certain bill of sale, and call your attention to the schedules setting forth the various items purporting to have been conveyed by that bill of sale, and ask you to look over those items and to tell the Court what, if any of them, were on the property on July 20, 1915?

Mr. Hawkins: That is objected to as incompetent, irrelevant and immaterial.

The Referee: Overruled.

725 Mr. Hawkins: Exception.

A. You want me to start at the top of it?

Q. Yes, and go right through it. if you please?

A. No. 1 Westinghouse Compound Engine was there.

Q. What was its condition? Describe its condition.

Mr. Hawkins: That is objected to as immaterial.

The Referee: I will take it.

Mr. Hawkins: Exception.

726 A. The compound engine was there without any trimming, as I have stated before, everything was stripped.

Q. Yes, but——

A. (Interrupting.) There wasn't anything left on it.

Q. Yes, but repeat your statement as it applies to each of those items?

A. Both numbers, 1, the Westinghouse Alternating and the Westinghouse Compound Engine were there. that is the bodies of the engine; and the direct connected double current generator was there, the 25 k.w.; the 15 horsepower motor, and

No. 1 item here, 16235, was not there; the transformers were not there; the tank was not there; the truck was not there; Fairbanks Scale was not there; Laidlaw-Dunn-Gordon Pump was there, but the inside was out of it; Westinghouse Electric Motor was not there; milling machine was not there; lathe No. 1 was not there, there was no tools of any description left there; the work benches were still there, but nothing on them; vises were gone; Westinghouse Type C 2-horsepower motor was gone; Westinghouse Type C inducting motor was gone; Westinghouse Type C 5-horsepower motor was gone; Westinghouse Motor about one-quarter horsepower was gone; the three lathes that he mentions here, only two could have been there at most at that time, the two that I have; I don't know the names of them. 727

Mr. Hawkins: I ask that be stricken out. only two could have been there.

The Referee: Well, you only got two, is that what you mean?

The Witness: Yes, sir. 728

Q. How many were there?

A. I don't know how many there was, quite a good many the first time I looked in there, but I know at the time we took possession from the time I went there, they were all carted away, some truck came in there for some place around there one day and I asked the agent there, and he said Mr. Tesla told this fellow—he runs a garage over there—that he could have them and he took a lot of stuff of that class. 729

Q. When was that?

A. I think that was along about a year before I got that notice.

Q. Proceed, please, with the other items.

730 A. Planer made by the Headley people, I see no planer there; planer made by Pedrick, no planers at all; no drill-press; that was gone; one large drill-press that I have; 36 lockers, they were all ripped to pieces; one testing fan motor—

Mr. Hawkins (interrupting): I ask that be stricken out.

The Referee: Denied.

Mr. Hawkins: Exception.

731 A. (Continuing.) That was gone; telephone and bell wire gone; quantity of lead cable gone; 4 radiators, they were gone; drills, bits, reamers, taps and all tools for milling machines and lathes at present time in storeroom located inside workshop, that was all gone; oil tanks, they were ripped up and they evidently had torn them apart because they wanted to get something inside of them, either lead or copper, I don't know which.

Mr. Hawkins: That is objected to.

The Referee: Strike it out.

Q. Leave out your conclusions about why they did it; what was the condition of them?

732 A. Just ripped to pieces; all the meters and starting boxes and switches had all been stripped off, only the bare slates left there; 2 Babcock & Wilcox Boilers, everything but the shell and tubes were gone, and feed pumps, just the housing was left; one hand—

The Referee (interrupting): What do you mean by that?

The Witness: Well, it is made out of cast iron, and the insides are brass, that is the valve seats and valves, they are always brass. They had been taken out. One hand blacksmith's forge was gone; toilets, urinals, wash basins, all ripped to pieces; 7 rheostats, desks,

safes, 3 meters, all those things were gone; one 733
set of storage batteries, tanks, submarine boat,
Westinghouse Motor 28292, Westinghouse
Motor Type C 5-horsepower No. 62320, West-
inghouse Motor Type C 5-horsepower No.
22070; 4 high-tension transformers in tanks
and switchboards, wiring drums, drafting
boards and tools all gone. Chairs, there was
two or three old chairs left there, was all;
clocks, no clocks; radiators, no radiators at all.

Q. What did you find the condition of the tower
to be?

Mr. Hawkins: I ask that the entire testimony 734
of this witness concerning the items mentioned
in the Defendants' Exhibit A, I think it was,
be stricken from the record as incompetent,
irrelevant and immaterial, especially because
that testimony bears no weight upon the ques-
tion as to whether that bill of sale was de-
livered as a security or as an absolute con-
veyance.

The Referee: Denied:

Mr. Hawkins: Exception.

Mr. Fordham: Read the last question.

The question was read by the stenographer.

Mr. Hawkins: That is objected to as incom- 735
petent, irrelevant and immaterial.

The Referee: I will let him describe what he
found. Overruled.

Mr. Hawkins: Exception.

A. The tower was badly rotted, the main supports
going up where the stairs were, the great big tim-
bers were rotted out, they were half gone and it is
a wonder they could stand up.

Mr. Hawkins: I move to strike that out.

The Referee: Yes, the wonder they ever
stood, strike that out.

736

Mr. Hawkins: Yes.

The Witness: The stairs leading up to the top of the ball were half rotted away so that we could not get up to the ball. I wanted to see what the ball was made out of and I took a man down there, a rigger, and he went up about two-thirds of the way, climbing up over it, and he was so afraid he came back.

Mr. Hawkins: I ask that he be stricken out.

The Referee: That he was afraid and came back, yes. I will let the fact stand that he did not go on up.

737

Mr. Hawkins: I ask the other be stricken out, that the rigger was sent up there.

The Referee: Denied.

Mr. Hawkins: Exception. And I also move that it be stricken out on the ground that it is in no sense rebuttal.

The Referee: Motion denied.

Mr. Hawkins: Exception.

Q. You may tell what the rigger did?

738

A. This big ball on top of the tower, you could not tell what it was made out of, whether it was brass or steel, as the ends of the wires where it had been grounded had rusted out and blown away, and there was a thousand and one little wires sticking out in every direction, so you could not see what it was made up of.

The Referee: You could not get up?

The Witness: You could not get up. You could get up so you could see the fibres of everything up there, you could see it plain enough, but the tower was rotted in no end of places, it had never been taken care of, nothing had ever been done to it.

Mr. Hawkins: I ask that that be stricken out.

The Referee: Yes, granted as to the last part. 739

Mr. Fordham: What is granted?

The Referee: He said nothing had been done to it.

Mr. Hawkins: And I ask also that it be stricken out that the tower had not been taken care of.

The Referee: Granted. Describe its condition.

Q. Yes, you may tell the condition of the tower, Mr. Bingham. Was the condition secure or insecure?

A. Insecure. There was none of the woodwork that had ever been painted, all that held it together was the big steel plates on the sides of it. 740

Q. As I understood, you say the woodwork was badly rotted out?

A. Rotted away, yes, sir.

Q. So that the tower in that condition was a menace to anybody passing near it, in view of its insecurity?

Mr. Hawkins: That is objected to as calling for a conclusion and a speculation.

The Referee: I think so.

Mr. Fordham: Not a speculation. The man is an expert in his own line.

The Referee: Objection sustained. 741

Mr. Hawkins: I ask that it be stricken out.

The Referee: Stricken out.

Q. Tell the Court from your own knowledge of structural materials, as an engineer, whether the tower was safe or unsafe, as you found it at that time?

Mr. Hawkins: That is objected to.

A. Absolutely unsafe.

The Referee: Have you sufficiently qualified him in that regard to testify at this time?

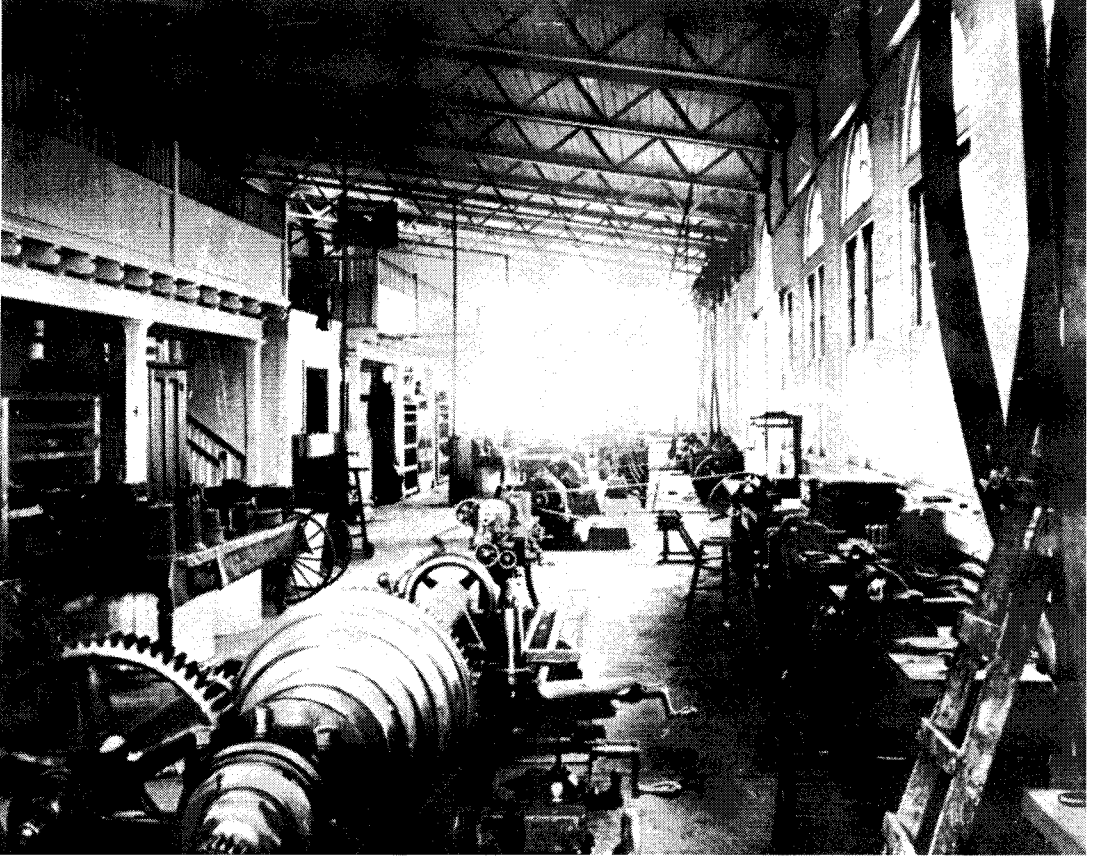

William Kolb

Figure A2-2

Workshop on north side of Wardencllyffe plant building.

Note: This photograph was not an exhibit for the case.

Q. (Interrupting.) Yes or no.

805

Mr. Fordham: Just a moment. If the Court please, I object to this on the ground that no foundation has been laid to qualify this witness.

The Referee: I will let him answer that question. Overruled.

Mr. Fordham: Exception.

A. Yes.

Q. At that time, to what use could the property be put?

Mr. Fordham: That is objected to, if the Court please, on the ground that it calls for the conclusion of an expert witness, and that there has no foundation been laid to qualify Mr. Tesla as an expert on real property value.

806

Mr. Hawkins: No, I have not asked him the value in that respect.

The Referee: I will take it.

Mr. Fordham: We except.

(The question was read.)

A. The property was expressly built for the transmission of wireless impulses.

The Referee: I do not think you understand the question. do you, Doctor? The question was to what use it was fitted, is that right?

Mr. Hawkins: Yes.

Mr. Fordham: I move to strike out this answer.

The Referee: Yes, strike it out.

Mr. Hawkins: I will formally except.

The Referee: I thought he misunderstood it.

A. The use it was built—

Q. (Interrupting.) No. Tell to what use it could be put at the time that deed was made?

808 A. At the time that deed was made it could have been used as a receiving wireless station.

The Referee: Yes.

The Witness: Pardon me for adding, it could also have been made use of as a transmitting station, but not to the extent that it could in the fully developed plant.

Q. But although it was not fully developed or permanently equipped, it could at that time have been used as a transmitting station?

A. Yes, sir.

Q. And as a receiving station?

809 A. As a receiving station.

Q. And there is now a large station of a similar kind very near your premises at Rocky Point, is there not?

Mr. Fordham: That is objected to, if the Court please, as immaterial and irrelevant.

The Referee: Overruled.

Mr. Fordham: Exception.

A. Yes, sir, there is, but it is of incomparably smaller power than mine.

810 Q. Are you familiar with the equipment and structures for the purpose of the receiving and transmission of wireless messages?

A. Yes, sir, I am.

Q. What has been your experience in that line, Doctor?

A. I have worked for thirty years on the art and have given all of the fundamental principles to it; and during at least twenty years I have been making apparatus of that kind and experimenting with it.

Q. Have you been making apparatus of that kind for sale?

A. Yes and no. I did attempt to start manu-

facturing several times, but could not find sufficient 811
encouragement, because at the time that I started
the art was not sufficiently developed for the gen-
eral public to have faith in it. I was ahead of the
time, and that was the only reason why it was im-
practicable to start manufacturing.

Q. Have you invented and put on the market
electrical apparatus for use in connection with wire-
less operations?

A. Yes, sir.

Q. At the time the deed was given, what was the
value of the premises at Rocky Point in their con-
dition at that time for the purpose of wireless re- 812
ceiving and transmitting uses?

Mr. Fordham: I object to that, if the Court
please, on the ground there is no proper foun-
dation laid to qualify this witness to speak of
the commercial or financial value of the prop-
erty at that time or at any other time. As to
the scientific value or possibilities of it, he has
already been interrogated. And it is objected
to, if that is the point of the question, that is
objected to on the ground it is needless repeti-
tion.

Mr. Hawkins: I submit, if your Honor
please, the witness is qualified to answer this 813
specific question, and has shown it by his tes-
timony here.

The Referee: I don't understand, Mr. Haw-
kins. Are you asking him to testify as to the
value of the land?

Mr. Hawkins: No, sir; I am asking him to
testify as to the value of the entire premises,
including the land and the buildings, but par-
ticularly the buildings.

Mr. Fordham: Well, commercially and

814 financially what is their value? And he knows nothing about it.

The Referee: I will overrule your objection and take it.

Mr. Fordham: Well, we except, if the Court please. I particularly call your Honor's attention to the fact that the testimony shows that the witness could not have known, because he had not been there for months before.

The Referee: I will take it for what it is worth.

Mr. Fordham: We except.

815 The Referee: Answer the question, Mr. Tesla, if you can.

A. At the time the deed was given a fair estimate of the value of the property would have been something like \$350,000, because the income——

Q. Never mind all that, you have answered my question.

The Referee: You mean by that, taking in the land and your scientific development on it?

The Witness: No; I estimate it on the basis of earning power as a transmitting and receiving plant for the purpose for which it was made.

816

The Referee: Had it ever earned anything at that time?

The Witness: Yes, but because I was carrying on the plan which would ultimately have yielded \$25,000 a day income, but at that time——

Q. (Interrupting.) Never mind, don't go on with that.

Mr. Fordham: I move to strike out the answer on the ground that the witness' explanation shows he is not qualified to make an

estimate, and that his estimate as made is not based on any sound financial or legal or other ground. 817

The Referee: I am inclined to agree with you, but—I don't see, Mr. Hawkins, that that is admissible.

Mr. Hawkins: I submit that that is admissible. The man shows he has worked in that line of business for many years and knows the value of that equipment for that purpose.

The Referee: If you want it to stand, I will let it stand.

Mr. Hawkins: Yes, sir I do.

Mr. Fordham: We except. 818

The Referee: The objection is overruled.

Mr. Fordham: Our motion is denied to strike out?

The Referee: Yes, motion denied.

Mr. Fordham: We except.

Q. Did that condition which you have just described, and those values, obtain at the time the bill of sale was given?

A. Oh, at the time the bill of sale was given the property was very much more valuable, it was worth—it could have earned at least five times as much as the Tuckerton plant on Long Island, and they had an income of something like forty thousand or fifty thousand dollars a year. 819

The Referee: Well, it could have earned if it had been completed. Now, was it in that position to earn?

The Witness: I must explain it. If it had been completed, it could have earned \$25,000 a day, but in that time in the state it was, if it had not been for my pushing the plant to completion, it could have earned something like

820

one hundred thousand or one hundred and twenty-five thousand dollars a year.

The Referee: What was it earning at that time?

The Witness: It was earning nothing.

Mr. Fordham: If the Court please, I move to strike out this last answer on the ground that it is contradictory to former testimony, because it appears that the deed and bill of sale were both given the same day, and it is impossible there could have been a wide difference in value between the few minutes when the deed was given and the bill of sale was given.

821

The Referee: I will let it stand.

The Witness: May I explain?

Q. Yes, explain.

A. Pardon me then, I did not understand the question. When I was asked when the deed was given, I had in mind when I first placed the property with Mr. Boldt, that was the valuation at that time.

Q. That was the first mortgage, wasn't it?

822

A. Oh, at the time the deed was given, now I understand better. Yes, that was 1915, the property was worth very much more because the art had been developed, the power stations had multiplied, the receivers had multiplied and where I would have had a hundred customers, then I would have thousands.

Q. Doctor, when you speak of the value at the time the bill of sale was given, do you mean the value at the time you first made a mortgage to Mr. Boldt?

A. No, sir, I mean at the time that the deed

was given, the property was worth more than 823
\$350,000.

Q. Yes, but what did you have in mind as the value when you spoke of the value as of the time the bill of sale was given?

A. I had in mind the value at the time I gave the mortgage to Mr. Boldt.

Q. Yes, the first mortgage?

A. Yes, the first mortgage.

Q. Upon the property to Mr. Boldt?

A. Yes, sir.

Q. Doctor, the property was developed for the purpose and use of a commercial wireless station, was it not? 824

A. Yes, sir.

Q. And so far as you know, it had no particular value for any other purpose, did it?

A. Yes, it might have been used for an electrical power plant for distribution.

Q. Yes.

A. In fact, the proposition was made to me at one time for that purpose.

Q. But looking at the situation from the local real estate market, it had no particular market value for any other purpose than that of wireless telegraphy, did it? 825

A. It might have as a factory building.

Q. But you are predicating your statement of values upon its uses for the purposes of wireless telegraphy, are you not?

A. For the purposes of the wireless art, yes.

Q. Wireless art?

A. Yes, in all its numerous applications.

Q. Do you remember Mr. Bingham saying that he went down to the property?

A. Yes, sir, I remember.

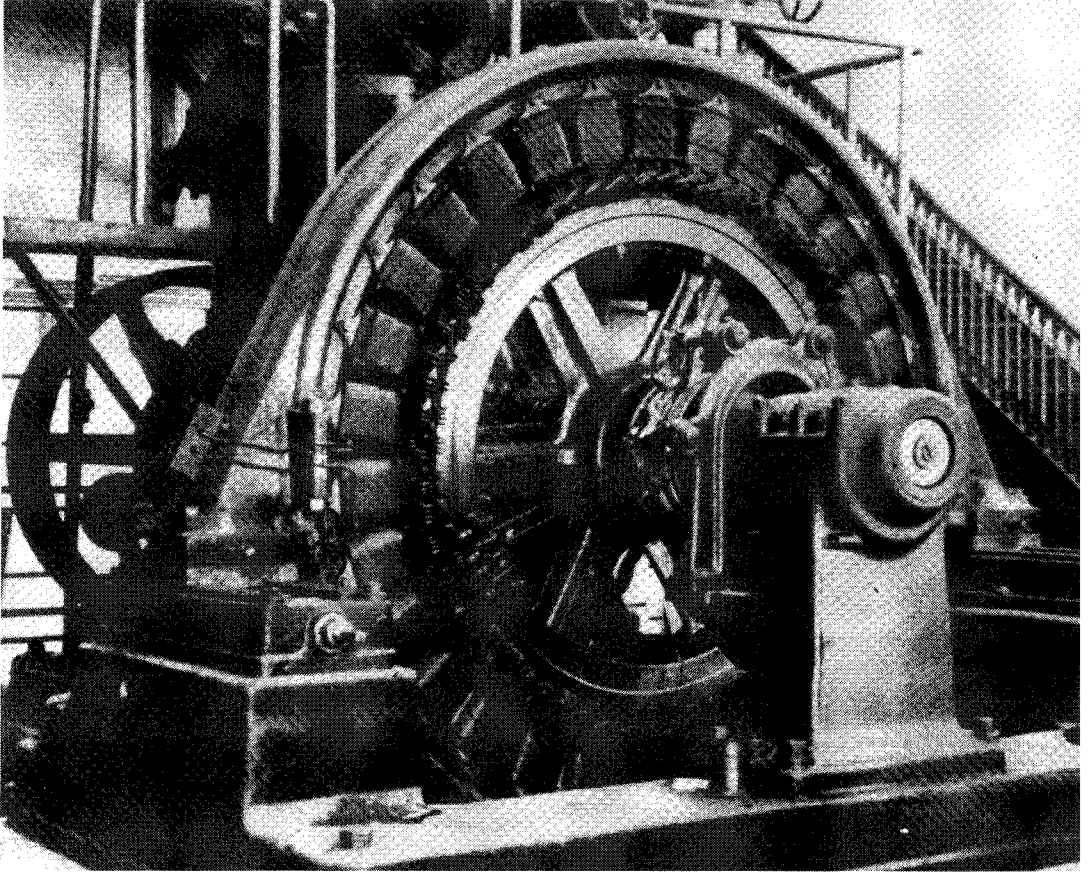

Bruce Kelley

Figure A2-3
Generating room of Wardencllyffe plant building.

Note: This photograph was not an exhibit for the case.

KNOW ALL MEN BY THESE PRESENTS, That I, WILLIAM N. HALLOCK, of the City, County and State of New York, party of the first part, for and in consideration of the sum of One Hundred and more dollars, lawful money of the United States, to me in hand paid, at or before the ensealing and delivery of these presents, by Waldorf-Astoria Hotel Company, party of the second part, the receipt whereof is hereby acknowledged, have bargained and sold, and by these presents do grant and convey, unto the said party of the second part, its successors and assigns, all and several the chattels located in the brick factory building near Skeleton Tower on premises owned or heretofore owned by Nikola Tesla, immediately adjoining on the southerly side the railroad tracks of the Long Island Railroad at Shoreham Station, Long Island, in the Town of Brookhaven, Suffolk County, New York, including but not limited to the chattels specifically set out on the Schedule hereto annexed. 926

TO HAVE AND TO HOLD the same unto the said party of the second part, its successors and assigns forever. And I do for my heirs, executors and administrators, covenant and agree to and with the said party of the second part, to warrant and defend the sale of the said chattels hereby sold unto the said party of the second part, its successors and assigns against all and every person and persons whomsoever. 927

IN WITNESS WHEREOF, I have hereunto set my hand and seal the eighth day of April in the year one thousand nine hundred and fifteen.

WILLIAM N. HALLOCK.

[L. S.]

928 SCHEDULE OF FOREGOING BILL OF SALE.

IN THE GENERATING ROOM.

- 1 Westinghouse auto compound No. 1497, size 16 by 27 by 16,
- 1 direct connecting Westinghouse alternating current generator 200 Kw., Serial No. 155407, complete with lubricator, gauge, Rheostadt, switchboard and switches,
- 1 Westinghouse engine, No. 4750, size 8½ by 8, with direct connected double current generator, 25 kw., Serial No. 168362, complete with lubricator, gauge, Rheostats, switchboard and switches,
- 929 1 15 H. P. Westinghouse motor, No. 162315,
- 4 Westinghouse transformers, 15 kw. type O. D.,
- 1 tank manufactured by Stoutenborough,
- 1 truck,
- 1 Fairbank's scale
- 1 Laidlaw Dunn-Gordon pump, No. 16473.

IN THE WORKSHOP.

- 1 Westinghouse electric motor, used for power to drive machine shop, type C, induction motor, 6 H. P., No. 162319,
- 930 1 Milling machine with tools complete, made by Brown & Sharp Manufacturing Company,
- 1 lathe made by Pond Machine Tool Company, No. P-3040, with tools, belting and shafting,
- 11 work benches,
- 4 vises,
- 1 Westinghouse, type C, 2 H. P. induction motor, No. 162278,
- 1 Westinghouse, type C, induction motor, 2 H. P. Serial No. 162272
- 1 Westinghouse, type C, induction motor, 5 H. P., No. L-74487

Defendants' Exhibit B.

- 1 Westinghouse motor, about $\frac{1}{4}$ H. P., No. 22190 931
3 lathes made by F. E. Reed of Worcester, Mass.
with shafting, belting and tools,
1 plainer made by Hendey Machine Co., with
shafting, belting and tools.
1 plainer made by Pedrick & Ayr, with shafting,
belting and tools.
1 F. E. Reed, hand drill press, shafting, belting
and tools,
1 large drill press by Prentice Brothers, with
shafting, belting and tools
36 lockers containing miscellaneous supply of
valves, joints, lubricators, fittings, scales, 932
switches, single and double pole, socket,
wrenches, fuses and plugs,
1 testing fan motor,
A quantity of telephone and bell wire,
A quantity of lead cable material,
4 radiators,
A quantity of drills, rose bits, reamers, taps, and
all tools for milling machine and lathes, at
present time in store room located in said
workshop,
2 oil tanks.
1 testing motion by Crocker Wheeler, $\frac{1}{2}$ H.P. 933
with Rheostat, No. 1000,
1 submarine boat,
1 clock
All of the aforesaid motors with starting boxes
and switches.

BOILER ROOM.

- 2 Babcock & Wilcox boilers with steam gauges
and water columns and with Metropolitan in-
jector and Worthington feed pump,

Defendants' Exhibit B.

- 934 1 other feed pump
1 hand blacksmith and forge
7 toilets, }
1 urinal, }
6 wash basins, } all adjoining boiler room.

TESTING OR LABORATORY ROOM.

- 7 Rheostats,
4 desks,
2 safes,
3 motors,
1 set of storage batteries and tanks
1 submarine boat,
935 1 Westinghouse motor, No. 28292
1 Westinghouse motor, type C, 5 H.P. No. 62320
1 Westinghouse motor, type C, 5 H.P. No. 22070,
4 high-tension transformers in tanks; and switch-
boards
Wiring drums
Drafting boards and tools,
24 chairs
2 clocks
14 radiators

STATE OF NEW YORK. }
County of New York } ss

- 936 On this eight day of April in the year of our Lord one thousand nine hundred and fifteen before me the undersigned personally came and appeared WILLIAM N. HALLOCK to me known and known to me to be the individual described in and who executed the foregoing instrument, and he acknowledged to me that he executed the same.

ISIDOR W. MULLER

Notary Public No. 45, Bronx County
Certificate filed New York County No. 85
Register's No. 6216
Commission expires March 30th, 1916

[NOTARIAL SEAL]

5494
Court Press, N. Y. C.

ACKNOWLEDGEMENTS

Dave Allenger, photographic imaging
and processing

Lewis Anderson, typographic design

INDEX

- AC motors
 - induction 1-3, 32, 109
 - laminated structures 1
 - synchronous 46
- Adams, Edward 72
- air spring 36, 37, 39
- Alexanderson, Ernst F.W. 24, 63
- alternator, HF 1, 3-7, 12-24, 28, 35, 46, 47, 75, 77, 94, 99, 128, 146, 155, 169-171, 176, 181, 182
 - Alexanderson 171
 - four-phase 59, 63
 - frequency multiplication 14, 15, 17, 19-23
 - in receiving circuits 19, 20
 - internal resistance 5, 14, 17
 - means of obtaining very high frequency 19-21
 - operating frequency in 1, 3, 6, 17, 20, 21, 29, 32, 75, 155, 171
 - output current 5
 - output waveform 3, 14, 15, 23
 - peripheral velocity 5
 - poles, number of 1, 4, 14, 15, 17, 18, 21
 - power output 6, 15, 19
 - rotational speed 1, 6, 12, 15, 16
 - two inductions 23
 - two-phase 59, 64
- American Electro-therapeutic Society 59
- American Institute of Electrical Engineers 3, 49
- antenna 9-12, 16, 51, 61, 65-67, 72, 74, 75, 81, 83-86, 89, 90, 96, 99, 103, 104, 107, 108, 114, 117, 119, 120, 122, 124, 126, 132-135, 140, 142, 143, 145, 151, 154, 155, 160, 162, 169-171, 175, 177, 183
 - charge density on 119
 - reduction in elevation of 110, 126
- Architects, Society of 59
- Atlantic Communication Company 85
- audion 100, 142, 167
- aurora borealis effect 110, 115
- Austin, Louis W. 142
- Babcock and Wilcox 42
- Beam, Victor S. 181
- Bell, Alexander Graham (telephone) 2
- Bessemer steel 64, 65
- boiler(s) 42
- bolometer 173
 - suggested improvement to 67
- Braun, Ferdinand 103
- breaks; *see* circuit controllers
- British Association for the Advancement of Science 50
- Brown & Sharpe 12
- Brown, Alfred S. 28
- capacitor(s); *see* condenser(s)
- Century Magazine*
 - "Tesla's Oscillator and Other Inventions" 41, 59, 70, 73
 - "The Problem of Increasing Human Energy" 73, 88, 90-95, 97, 105, 115, 121, 122, 157, 158
- Chicago Exposition of 1893 39, 40, 41, 52, 53
- Chicago World's Fair; *see* Chicago Exposition
- circuit controllers
 - elimination of 14, 15
 - frequency multiplication 21, 58, 59, 79, 80, 152
 - means of obtaining very high frequency in 21
 - mercury 21, 76-82, 152
 - Poulson arc 48, 52
 - quenched gap 50, 51, 62, 183
 - rotary break 48, 52-61, 65, 76-82, 127, 152
 - series 51
- Clark, F. W. 12
- Colorado Springs Experimental Station
 - column dimensions 119-120
 - maximum potential 112
 - purpose of experiments 109, 110, 113, 137, 170
- Columbia College 6
- commercial oscillator (transformer) 41, 54
- condenser(s)
 - adjustable 11, 12, 94, 103, 117, 174
 - auxiliary circuit 11
 - dielectrics 32, 33
 - magnification by 11, 146
 - manufacture of 33-34
 - patents 30-32
- Conductivity
 - of atmosphere 110, 126, 128-130, 132
 - of the earth 2, 128-130, 132-135,

- 137-141
- Continuous waves
damping factor 44, 51, 61, 72, 174
production of 14, 27, 44, 51, 61, 64, 65, 69, 70, 77, 79-81, 90, 146, 152, 153, 170, 174, 175, 176
- Cripple Creek, Colorado 109
- Crocker Wheeler Electric Motor Company 63
- Crocker, Francis Bacon 63
- Crookes, William 122
- Damped waves 62, 92, 109, 113, 146, 176
production of. (*See also* continuous waves), 11, 44, 50, 54-57, 61, 70, 84
- Daniels, Josephus 183
- De Forest, Lee 100
- demonstrations, general
high frequency transformer 82
oscillatory apparatus 52, 53
production of DC without commutator 39
- demonstrations
conductivity of low-pressure air 27, 125-128
discharge between discs 70-72
flames out of head 56
lighting lamps 8, 56, 70, 87, 89, 90, 93, 94, 96
little fan in evacuated tube 95
long distance transmission and reception 23-29, 85, 173, 177, 183
melting of tinfoil 62
one-wire energy transmission 7, 94
remote control 158
running of motors 36
transformation of primary oscillation 72
tunable RF circuits 11, 12
- Dewar, James 122
- dielectrics; *see* condenser(s)
- direct currents, production of high-potential 64, 65, 153
- direct currents, production of. (*See also* alternator), 39
- dischargers; *see* circuit controllers
- Dunn, Gano 6
- Edison, Thomas Alva, phonograph 2
- electrical charge density of earth's surface 134
- earth resonance 140
- efficiency, transmitter 140
- electrical discharge(s)
condenser 15, 48-50, 62, 65, 68, 69, 112, 113, 146, 175
length 74, 111
sparks & streamers 50, 72, 74, 83, 90, 92, 111, 112, 115, 117, 121, 122, 126, 146, 151, 176
- electrical energy, transmission of
AC system 1, 109
one wire 7, 9, 86, 88-90, 93, 94, 102
two wire 102
wireless xi, 1-2, 12, 16, 26-29, 51-87, 125-147, 156
- Electrical Review* (N.Y. and London) 84, 105
- Electrical World and Engineer* 82, 156
- electromagnetic radiation, suppression of 44, 51, 74, 144, 145
- energy
elastic 74
frictional 99, 131, 140
recovery of 74, 75, 130-133, 140
storage 62, 68, 74, 112, 113, 131, 140
- engineering, definition of 137
- Experiments with Alternate Currents of High Potential and High Frequency* 156
- Fessenden, Reginald A. 33, 60
- Fourier harmonic 124
- Franklin Institute 51, 52, 69, 86, 87, 94
- Frequency multiplication. (*See also* alternators), 11
- Fundamental tone. (*See also* harmonic) 11, 124
- galvanometer, string 28
- Gerlach, Hotel 23, 25, 28, 169
- Gilder, R. Watson 95
- Goldschmidt, Rudolf 21, 23, 178
- harmonics, production of. (*See also* Fourier harmonic), 11, 14, 15, 17, 90, 92
- Helmholtz, Hermann Ludwig Ferdinand von 5, 39, 52-55, 111
- Hertz-wave theory 142
- Hertzian
circuits 104
radiations or waves 125, 126
- Hewitt, Peter Cooper 48
- Hogan, John V.L. 5
- induction
mutual 23, 168
self 11, 39, 48, 74, 75, 84, 86, 90, 102, 103, 114, 160, 174, 175
flux cutting ($v \times B$) 23
- Institution of Electrical Engineers 9, 95, 97
- inventions claimed or used by others
compressed air condenser, Fessenden 32, 33, 60

- four-circuit arrangement, Braun, Marconi 103
- frequency multiplication, Goldschmidt 21, 23
- improved HF alternator armature, Hogan 5, 6
- improved rotary break, Marconi 48, 58
- Tesla coil, Thomson 48
- wireless remote control, Hammond 19, 158
- wireless system, Poulsen 48, 52
- wireless transmitter with phase differentiated power supply, Green 60
- inventions, unpatented 61
- isochronous currents, production of 36, 39, 40, 42-46, 57, 58, 64, 83, 170, 171
- Jefferson, Joseph 59
- Johnson, Robert Underwood 95
- King Albert 99
- Lamp of Aladdin 134
- lamps 132
 - button lamp 87
 - incandescent lamps 88, 93, 127
 - lamps 50, 56, 87
 - mercury arc 83
 - phosphorescent bulb 87
 - vacuum tube 8, 52, 83, 87, 159
- Langley, Samuel Pierpont 67
- Lenard, Philipp von 122
- Lord Kelvin 27, 48, 50, 82, 87, 111, 122, 129, 134
- low frequencies, use of 24, 25, 74, 100, 143, 169
- Lowenstein Radio Company 183
- Lowenstein, Frederick (Fritz) 178, 179
- magnifying transmitter 72, 73, 91, 105
- Marconi apparatus 48, 58, 103-105, 136
- Marconi patents
 - 11,913 103, 104
 - 676,332 136
- Marconi, Guglielmo 85, 103, 105, 106, 154
- Marshall, W. 11
- Martin, Thomas Commerford 4, 6-8, 19, 32, 40, 41, 49-51, 59, 69, 70, 73, 86, 87, 94, 95, 125
- McGraw-Hill Book Company 156
- Moon's shadow analogy 138, 139
- Morris, John T. 181
- motors; *see* AC motors
- multiplexing; *see* sectional circuits
- National Electric Light Association 51, 69, 70, 86, 87, 94
- Nauen, Germany 142
- Netter, Raphaël 61
- New York Supreme Court, Suffolk County 185
- Niagara Falls 132
- Nobel Prize 48, 51
- nonradiative circuits 44
- Osborn, H. Fairfield 71
- oscillators, electrical 48
- ozonator 119
- Patent Office, U.S. 27, 125
- penetrating the media 2, 105, 138
- period, adjustment of 10, 11, 39, 83, 102-104, 117, 174
- Pickard, Greenleaf Whittier 85, 176, 177
- potential, maximum 112, 121, 127
- Pittsburgh 1, 64
- Poulsen arc 52
- propagation, law of 2, 138, 140, 141, 143
- Pupin, Michael 141
- quenched gap; *see* circuit controllers
- radio engineers 128, 140, 141
- receiver(s)
 - beat-frequency oscillator 19, 26, 45, 46
 - ideal, the 99-100
 - magnetic 25, 27-29, 161-163
 - portable 32, 155, 170
 - small-mass resistance (bolometer) 67, 173
 - telegraphic 161
 - telephonic 25, 27, 29, 160-162, 173, 174
 - terminal(s) of capacity 61, 99, 103, 110, 117, 134, 160-162
 - tuning of 23, 24, 26, 28, 55, 56, 71, 90, 92-94, 96, 99, 100, 102, 103, 106, 127, 131, 133, 161, 167-170, 177
 - tuning tables 71, 72, 151
- rectifier, mercury 48
- resonant rise 5, 72, 99, 100, 103
- Roentgen, Wilhelm Conrad 122
- rotating magnetic field 3, 21, 22
- Royal Institution 9, 95
- Sayville 2, 133, 142, 178, 179
- Scherff, George 183
- Schmidt, Albert 63-65
- sectional circuits 24, 123, 124
 - tuning of 124
- secure communications 23, 24, 104, 158
- Seeley, G.D. 27, 125, 127
- selectivity 24, 104
- self-inductance coil 74, 75, 84, 103, 114, 160
 - adjustable 10-12, 94, 102, 103, 174, 175
- Shallengberger, Oliver B. 64
- Slaby, Adolphus 122

- Societe pour la Foundation le l'Institute
Nikola Tesla 181
- Sommerfeld, Arnold N. 75, 133
- spark gap; *see* circuit controllers
- static interference 167
- Steinmetz, Charles 35
- Stone, John Stone 16, 124
- telautomaton 19, 152, 157, 158
- Telefunken 179
- Telluride, Colorado 109
- Tesla coil 48
- Tesla employees 12, 27, 28, 179
- Tesla laboratories
- 89 Liberty Street, N.Y. 1
 - 175 Grand Street, N.Y. 1, 9, 10, 12
 - 35 South Fifth Avenue, N.Y. 17, 23, 25, 33, 42, 46, 55, 57, 59, 60, 71-73, 124, 169
 - 46 East Houston St., N.Y. 26-28, 32, 33, 43, 44, 46, 55, 58, 62, 64-67, 71, 73, 82, 107, 108, 110, 123-126, 128, 129, 137, 159-161, 163, 169, 179
 - Colorado Springs 32, 61, 62, 74, 82, 88-124, 145, 146, 163, 167, 170, 172, 174-176
 - Wardenclyffe. (*See also* Wardenclyffe), 60, 61, 81, 112, 148-156, 159, 160, 172, 173, 179
- Tesla lectures
- Columbia College (American Institute of Electrical Engineers) 6, 7, 9, 11, 49
 - Franklin Institute 51, 52, 69, 86, 87, 94, 125
 - National Electric Light Association 51, 52, 69, 70, 86, 87, 94, 125
 - New York Academy of Sciences, The 24, 151, 158-160, 162, 163, 167
 - Royal Institution 9, 67, 95
- Tesla papers, American Institute of Electrical Engineers 3
- Tesla patent licensees 177-179, 183
- Tesla patents
- U.S. Pat. No. 1,119,732 111, 113, 144
 - U.S. Pat. No. 390,721 22
 - U.S. Pat. No. 447,921 3, 13, 16-19
 - U.S. Pat. No. 454,622 11
 - U.S. Pat. No. 462,418 49
 - U.S. Pat. No. 464,667 30
 - U.S. Pat. No. 511,916 37, 38
 - U.S. Pat. No. 514,168 53
 - U.S. Pat. No. 567,818 31
 - U.S. Pat. No. 568,178 101, 102
 - U.S. Pat. No. 568,179 57
 - U.S. Pat. No. 568,180 57
 - U.S. Pat. No. 577,671 34
 - U.S. Pat. No. 609,245 76
 - U.S. Pat. No. 613,809 157, 158
 - U.S. Pat. No. 645,576 55, 72, 98, 99, 125, 127, 177, 183
 - U.S. Pat. No. 649,621 72, 98, 125, 177, 183
 - U.S. Pat. No. 787,412 139
- Tesla residences
- Hotel Gerlach 23, 25, 28, 169
 - Waldorf-Astoria 185
- Tesla system, uses of 12, 52, 61, 64, 77, 106, 125, 151, 160
- Tesla turbine 12, 15
- "Tesla's Oscillator and Other Inventions;" *see* *Century Magazine*
- "The Problem of Increasing Human Energy;" *see* *Century Magazine*
- Thomson, Elihu 48
- Thomson, William. (*See also* Lord Kelvin), 48
- tikker 159
- "Transmission of Electric Energy Without Wires" 156
- transmission-reception distance statements
- Colorado 85, 173, 177, 183
 - New York 26-29, 173
- transmitting apparatus
- Colorado Springs oscillator 61, 62, 82, 89-92, 111-122
 - flat spiral-coil oscillator 83-85, 151
 - Lowenstein Radio Co. 178, 183
 - one wire 93, 94
 - Wardenclyffe 148-155
- transoceanic communications
- using earth currents 83-85, 105, 106, 137, 177, 185
 - using electromagnetic waves 142
- Tuckerton 2, 178
- tuned circuit(s)
- concatenated 96, 99-102
 - four 98, 177
- Twain, Mark (Samuel Clemens) 59
- United States Navy 158, 177, 178, 183
- universal relay 170
- unpublished designs 24, 158, 161, 162, 173
- vacuum pressure process 33
- Wardenclyffe plant
- commercial use 67, 106, 110, 113, 126, 143, 153, 159, 170
 - dimensions 190-191, 200-203

- inventory 232-234
- operating frequencies 155
- projected earnings 226, 227
- property value 226
- Wardencllyffe tower
 - height 149
 - shaft dimensions 200, 203
 - tower-plant separation 151
- Wein, Wilhelm Carl 51
- Western Union Building 28
- Westinghouse
 - alternator(s) 63-65
 - transformer(s) 64
 - transformer(s), improvement of 64, 65
- Westinghouse Electric & Manufacturing Co. 63-65, 181
- Westinghouse, George 65
- White Company 6
- Wireless methods
 - earth conduction 74, 75, 84, 85, 132, 137, 142
 - electromagnetic induction 93
 - electromagnetic radiation (radiated energy) 74, 75, 132
- Woolworth Building 33
- Zenneck, Jonathan 16, 133

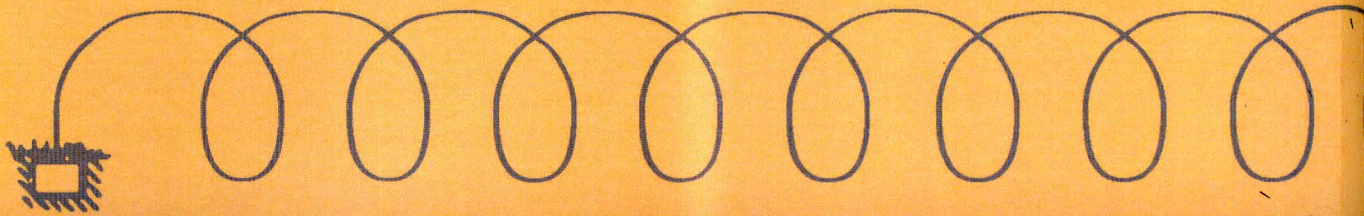

ISBN 978-189381701-2

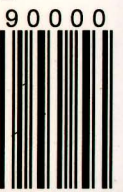

9 781893 817012

90000